

## 200-800W, 10 to 100V Programmable Power Supplies

<https://product.tdk.com/en/power/zplus>  
[www.emea.lambda.tdk.com/zplus](http://www.emea.lambda.tdk.com/zplus)



Industrial



Test



Suitable for bench or 2U rack mounting, the Z+ is a very compact programmable power supply offering power levels from 200 to 800W, voltages of up to 100V and currents of up to 72A. Multiple remote programming methods are available including built-in USB, RS232 & RS485 and optional LAN, GPIB & isolated analogue interfaces. The units can operate in either constant current or constant voltage mode and accept a wide 85-265Vac input. The product is backed with a five year warranty.

Features	Benefits
• 2U high	• Low Profile
• Built-in USB, RS-232 & RS-485 Interface	• No Additional Cost
• Optional LAN, GPIB & Isolated Analog Programming	• Programmable Remote Operation
• Bench or Rack Mount	• Flexible Mounting
• Constant Current or Voltage Modes	• Seamless Transition (Auto Crossover)
• Five Year Warranty	• Low Cost of Ownership

Model Selector								
Model	Voltage Adjust Range	Current Adjust Range	Max Power (W)	Ripple 5Hz-1MHz (mV)	Noise 20MHz BW (mV)	Ripple 5Hz-1MHz (mA)	Efficiency % (100-200VAC)	Front Panel Output Jacks (Option)
Z10-20-U	0 - 10	0 - 20	200	5	50	25	80 / 82	Yes
Z10-40-U	0 - 10	0 - 40	400	5	50	70	80 / 82	Yes
Z10-60-U	0 - 10	0 - 60	600	5	50	150	80 / 82	Yes
Z10-72-U	0 - 10	0 - 72	720	5	50	180	80 / 82	Yes
Z20-10-U	0 - 20	0 - 10	200	6	50	15	82 / 84	Yes
Z20-20-U	0 - 20	0 - 20	400	6	50	40	81 / 83	Yes
Z20-30-U	0 - 20	0 - 30	600	5	50	75	82 / 84	Yes
Z20-40-U	0 - 20	0 - 40	800	5	50	100	82 / 84	Yes
Z36-6-U	0 - 36	0 - 6	216	6	50	8	83 / 85	Yes
Z36-12-U	0 - 36	0 - 12	432	6	50	15	83 / 85	Yes
Z36-18-U	0 - 36	0 - 18	648	5	50	25	84 / 85	Yes
Z36-24-U	0 - 36	0 - 24	864	5	50	31	84 / 85	Yes
Z60-3.5-U	0 - 60	0 - 3.5	210	7	50	4	83 / 85	Yes
Z60-7-U	0 - 60	0 - 7	420	7	50	8	83 / 85	Yes
Z60-10-U	0 - 60	0 - 10	600	12	50	8	83 / 85	Yes
Z60-14-U	0 - 60	0 - 14	840	12	60	28	83 / 85	Yes
Z100-2-U	0 - 100	0 - 2	200	8	80	3	83 / 85	No
Z100-4-U	0 - 100	0 - 4	400	8	80	3	84 / 86	No
Z100-6-U	0 - 100	0 - 6	600	15	80	5	84 / 86	No
Z100-8-U	0 - 100	0 - 8	800	15	80	12	84 / 86	No

### Part Number Example

<b>Z10</b>	-	<b>20</b>	-	<b>LAN</b>	-	<b>L</b>	-	<b>U</b>
Series and output voltage		Output current		blank USB, RS-232/RS-485 (All models) IEEE GPIB Interface** IS510 Voltage Programming Isolated Analog Interface** IS420 Current Programming Isolated Analog Interface** LAN LAN Interface (Complies with "LXI" Class C)		blank No front output jacks -L Output jacks* -L2 Output (insulated) jacks*		U North America AC cord blank No AC Cord Other countries upon request (special order)
						Preferred		

\* Special order, requires wide body case (105mm wide), limited to 24A maximum

\*\* Requires wide body case (105mm wide)

Related Products		
Type	Part Number	Description
Z+ High Voltage Series Datasheet	<a href="#">Z+ High Voltage</a>	Z+ 160V to 650V Programmable Power Supplies
19" Rack Housing	<a href="#">Z-NL100</a>	Accepts four 105mm width units or six 70mm width units
Dual/Triple Housing	<a href="#">Z-NL200</a>	Accepts two 105mm case units or three 70mm case units
Blanking Panel	<a href="#">Z-BP</a>	70mm Blanking Panel For 19" Rack
Blanking Panel	<a href="#">Z-WBP</a>	105mm Blanking Panel For 19" Rack
Cable	<a href="#">Z-RJ45</a>	Serial Link Cable (One is included with each power supply)
DB9 Cable	<a href="#">Z-485-9</a>	Communication Cable RS-485
DB9 Cable	<a href="#">Z-232-9</a>	Communication Cable RS-232
Cable	<a href="#">Z-U</a>	2m North American AC cord (Included with U option)

Specifications						
Model		Z10	Z20	Z36	Z60	Z100
<b>Input</b>						
Input Voltage range	Vac	85 - 264 (Derate for 85-100Vac input when Ta>40°C); Z10-72-U (66A), Z20-40-U (36A), Z36-24-U (20A), Z60-14-U (12.5A), Z100-8-U (7.5A)				
Input Frequency	Hz	47 - 63				
Input Current (100/200Vac)	A	200W: 2.76 / 1.37, 400W: 5.25 / 2.57, 600W: 10 / 4.9, 800W: 10.3 / 5.1				
Inrush Current at 200Vac (typ) (Cold Start)	A	200W: <30, 400W: <25, 600W: <25, 800W: <30				
Leakage Current (220Vac)	mA	<1.2				
Power Factor (100/200Vac)	-	>0.99 / 0.98				
Harmonic Compliance	-	Meets IEC61000-3-2 Class A				
Hold Up Time (typ)	ms	200W: 15, 400W: 15, 600W: 15, 800W: 10				
Efficiency	-	See Model Selector Table				
Conducted & Radiated EMI	-	IEC/EN61326-1, -B radiated, -A conducted, designed to meet EN55032/EN55024				
Immunity	-	See IEC61000 reports on website				
Insulation Class	-	Class I				
Safety Certifications and Markings	-	IEC/UL/CSA/EN61010-1,60950, CE Mark and UKCA Mark				
<b>Output</b>						
Output Voltage and Current Adjustment	-	See Model Selector Table				
Load Regulation (CV Mode)	mV / %	2mV + 0.01% of rated voltage over 0 - 100% load change				
Line Regulation (CV Mode)	mV / %	2mV + 0.01% of rated voltage over a 85 - 132 or 170 - 265Vac line change				
Transient Response Recovery Time <sup>(1)</sup>	ms	1				
Load Regulation (CC Mode)	mA / %	5mA + 0.01% of rated current over 0 - 100% Vout change				
Line Regulation (CC Mode)	mA / %	2mA + 0.01% of rated current over a 85 - 132 or 170 - 265Vac line change				
Ripple & Noise (CC or CV Mode)	-	See Model Selector Table				
Temperature Coefficient (CV Mode) <sup>(2)</sup>	ppm/°C	30 (following 30 minute warm up)				
Temperature Stability (CV Mode) <sup>(2)</sup>	%	0.02 of rated voltage over 8 hours following 30 minute warm up time				
Warm-up Drift (CV Mode) <sup>(2)</sup>	mV / %	<0.05% of rated voltage + 2mV of rated output voltage (after 30 min warm up period)				
Temperature Coefficient (CC Mode)	ppm/°C	100 (following 30 minute warm up)				
Temperature Stability (CC Mode) <sup>(2)</sup>	%	0.05 of rated current over 8 hours following 30 minute warm up time				
Load Regulation Thermal Drift (CC Mode) <sup>(2)</sup>	%	< 0.05 of rated current over 30 minutes after load change				
Warm-up Drift (CC Mode) <sup>(2)</sup>	%	±0.1 of rated output current over 30 minutes following power on				
Up Programming Resp Time (CV Mode) (10-90% or 90-10% of Vmax) <sup>(2)</sup>	ms	15	30	30	50	50
Down Programming Resp Time (CV Mode) Full Load (10-90% or 90-10% of Vmax) <sup>(2)</sup>	ms	12	25	30	40	50
Minimum Load	-	No minimum load required				
Overcurrent Protection	-	User programmable, can be set to foldback mode				
Overvoltage Protection	V	Shut down. User programmable				
Overtemperature Protection	-	User selectable - latched or non-latching				
Remote Sense Compensation (per wire)	V	1	1	2	3	5
Remote On/Off	-	By applied voltage or dry contact relay (user selectable logic)				
DC Good	-	Open Collector, Low on fail				
Communication	-	RS232, RS485 & USB standard, IEEE488 (GPIB) & LAN optional				
Indicators	-	Green LEDs: FINE, MENU, PREV, PROT, REM, OUTPUT, CV, CC Red LED: PROT (OVP, UVP, OTP, FOLD, AC FAIL).				
Display	-	4 digits. Accuracy 0.5% of rated voltage or current ±1 count				
Parallel Operation	-	Up to 6 units				

Specifications		Z10	Z20	Z36	Z60	Z100
<b>Environmental</b>						
Operating Temperature	°C	0 - 50, full load				
Storage Temperature	°C	-20 to +85				
Humidity (Non condensing)	%RH	20 - 90 operating, 10 - 95 storage				
Cooling	-	Internal fan				
Altitude	m	3000. Derate ambient temperature above 2000.				
Withstand Voltage (For 1 minute)	Vac / Vdc	Input to Ground 2kVac, Input to Output 3kVac, Output to Ground 1380Vdc				
Isolation Resistance	MΩ	>100 at 25°C, 70%RH & 500Vdc				
Vibration (Non operating)	-	IEC60068-2-64				
Shock (Unpacked)	-	IEC60068-2-27: 20G half sine wave, for a duration of 11ms				

Specifications		200W	400W	600W	800W
<b>Other</b>					
Weight (Typ)	g	Standard body 1,900; Wide Body 2,400			
Size (WxHxD)	mm	Standard body: 70 x 83 x 350; Wide Body 105 x 83 x 350			
Size (WxHxD)	Inches	Standard body: 2.76 x 3.27 x 13.78; Wide Body 4.13 x 3.27 x 13.78			
Connectors	-	See outline drawings			
Case Material	-	Metal case, plastic front panel			
MTBF - MIL HDBK-217F <sup>(3)</sup>	Hours	78,778	78,569	72,221	72,221
Warranty	Years	5			

**Notes**

See website for detailed specifications, test methods and installation manual

- (1) Recovery to within 0.5% of rated voltage after a load change of 10-90% (Output current 10-100% of I<sub>max</sub>)
- (2) [200W models](#). See specification on website for [400](#), [600](#) & [800W models](#)
- (3) Ground, Fixed. Excludes fan. See reliability data on website

## Z+ Outline Drawing (70mm wide)

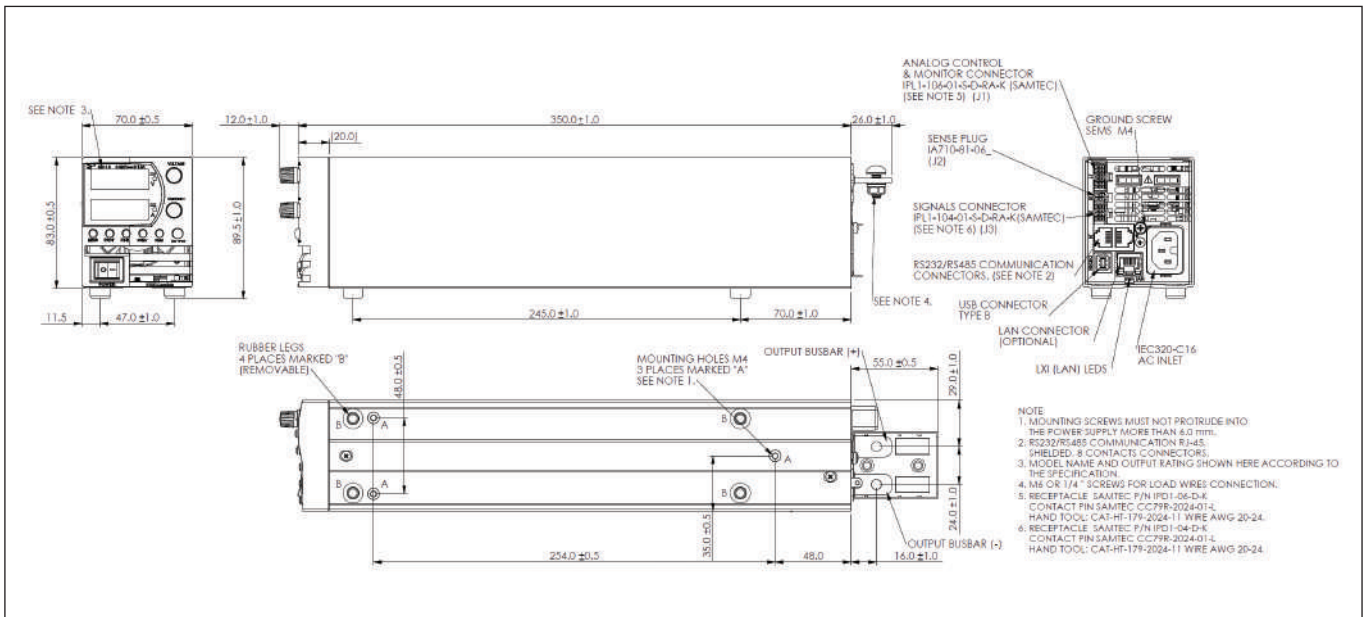

Z+ Outline Drawing (105mm wide) with Optional IEEE, Isolated Analog Interface

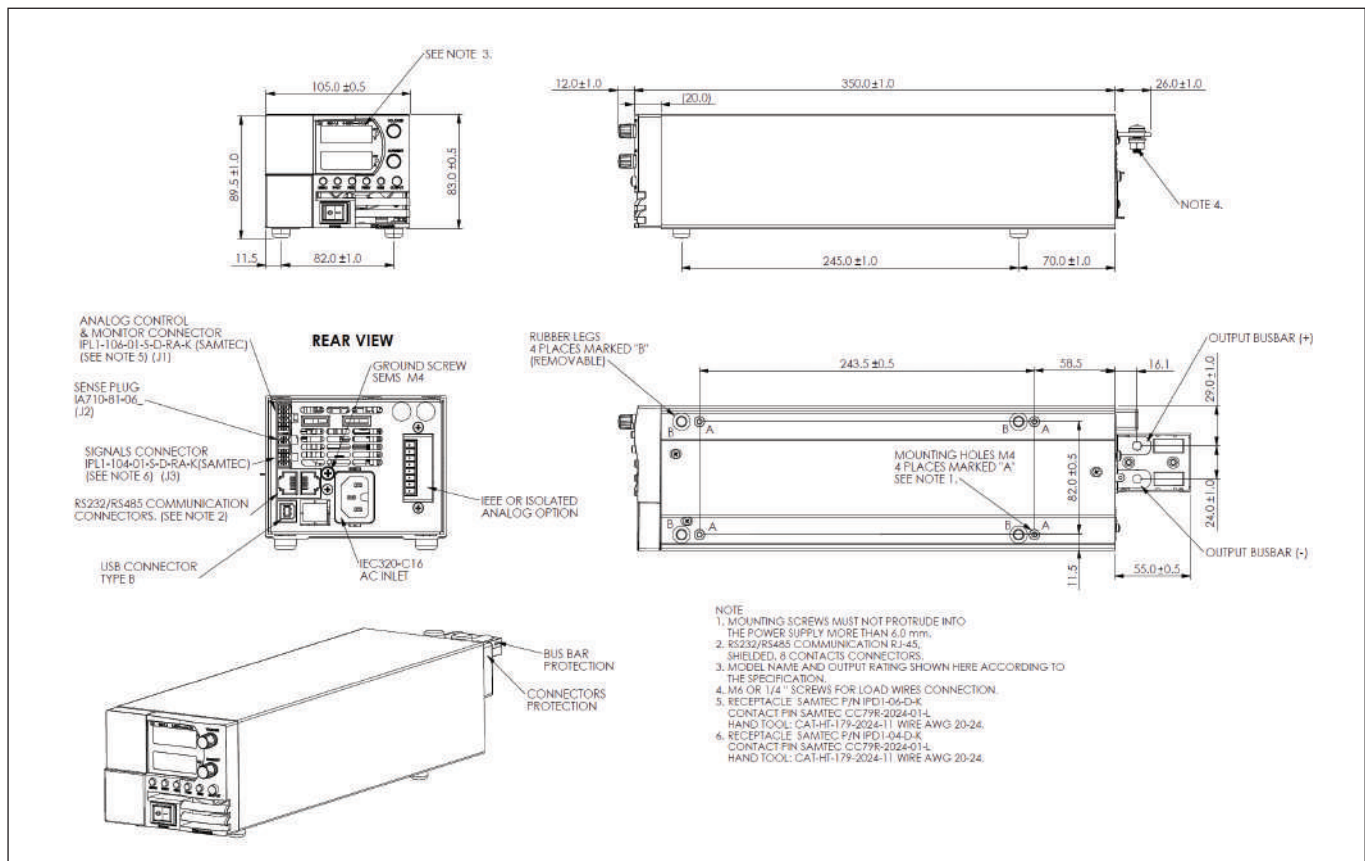

Z+ Outline Drawing (105mm wide) with Optional Front Panel Jacks

