

# pendulum

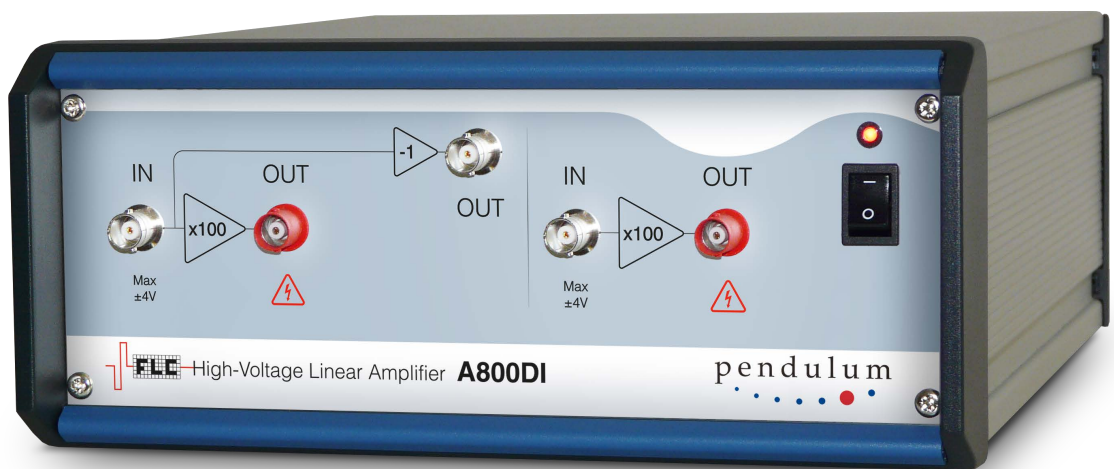

## DUAL CHANNEL LINEAR AMPLIFIER WITH PHASE INVERTER

Model A800DI



HIGH VOLTAGE  
1600Vpp 60mA

FIXED GAIN  
100x

BROADBAND  
DC to ca 300 kHz

LOW OUTPUT IMPEDANCE  
<0.1  $\Omega$

HIGH SLEW RATE  
500 V/ $\mu$ s

## GENERAL DESCRIPTION

The **A800DI** is a general purpose linear amplifier designed for laboratory use. It is based on a fast high-voltage operational amplifier with a feedback network chosen to give a voltage amplification of 100 times. Any function or arbitrary waveform generator with low output impedance and output voltage up to  $\pm 10$  V can be used as an input device.

The instrument contains **two identical amplifiers** sharing a **common power supply**.

The instrument also includes a **low voltage phase inverter** that facilitates driving the two high voltage outputs in counter-phase.

The amplifier outputs high voltage signals at high frequency. It is, thus, imperative for the safe operation that the user understands the possibilities and limitations of the instrument. Isolated BNC output connector is used to comply with safety requirements.

## INPUT AMPLITUDE

The amplitude of the input signal should normally be kept within  **$\pm 4$  V**. The input protection network limits the signal amplitude delivered to the power amplifier to a safe value. It also effectively cuts accidental spikes and overshoots. However, large and prolonged overvoltage at the input may blow the microfuse in the input protection circuit.

## TROUBLESHOOTING

Problem	Condition	Solution
No output	Power switch is not lit	Check the mains fuse located on the back
No output or very small, distorted signal	Power switch OK	Check the input microfuse located <u>inside</u> the device.
Constant high voltage output	Without any input signal	Amplifier failure. Contact <a href="mailto:service@pendulum.se">service@pendulum.se</a>

You should suspect a blown input microfuse if the output is about zero or the amplifier is producing a very low voltage, distorted copy of the input signal (due to the capacitive coupling through the blown fuse).

Spare microfuses are provided inside the instrument. They look like small metal cans and are placed in white holders. The resistance of a good fuse is in the order of 46 ohm. It is imperative to disconnect the power cable and wait at least a minute before opening the case. If possible, contact [service@pendulum-instruments.com](mailto:service@pendulum-instruments.com) for advice.

Keep input signals within  $\pm 4$  V range.

Never connect any high voltage output to any input or output of the instrument!

## PHASE INVERTER

The **A800DI** contains a phase inverter which shares the input with the first amplifier (see the drawing on the next page). The phase inverter is intended to allow a bridge connection of the amplifiers and the load to achieve double amplitude of the output signal. In such a case, the output of the phase inverter should be connected to the input of the second amplifier, an external signal supplied to the input of the first amplifier and the load connected between the outputs of both amplifiers as in the example below.

Observe, that both sides of the connected load are actively driven and must be isolated from the ground. The voltage over the load is in this case  $U_1 - U_2 = U_1 - (-U_1) = 2U_1$  since  $U_2 = -U_1$ .

It is, of course, possible to supply separate signals to the low voltage inputs of both amplifiers and still use the differential connection of the load, as in the drawing. The amplifiers can also be used as two independent units sharing the common ground reference.

### PLEASE NOTE:

In the differential configuration - isolate the load from ground and use two separate oscilloscope probes to monitor the voltage over the load.

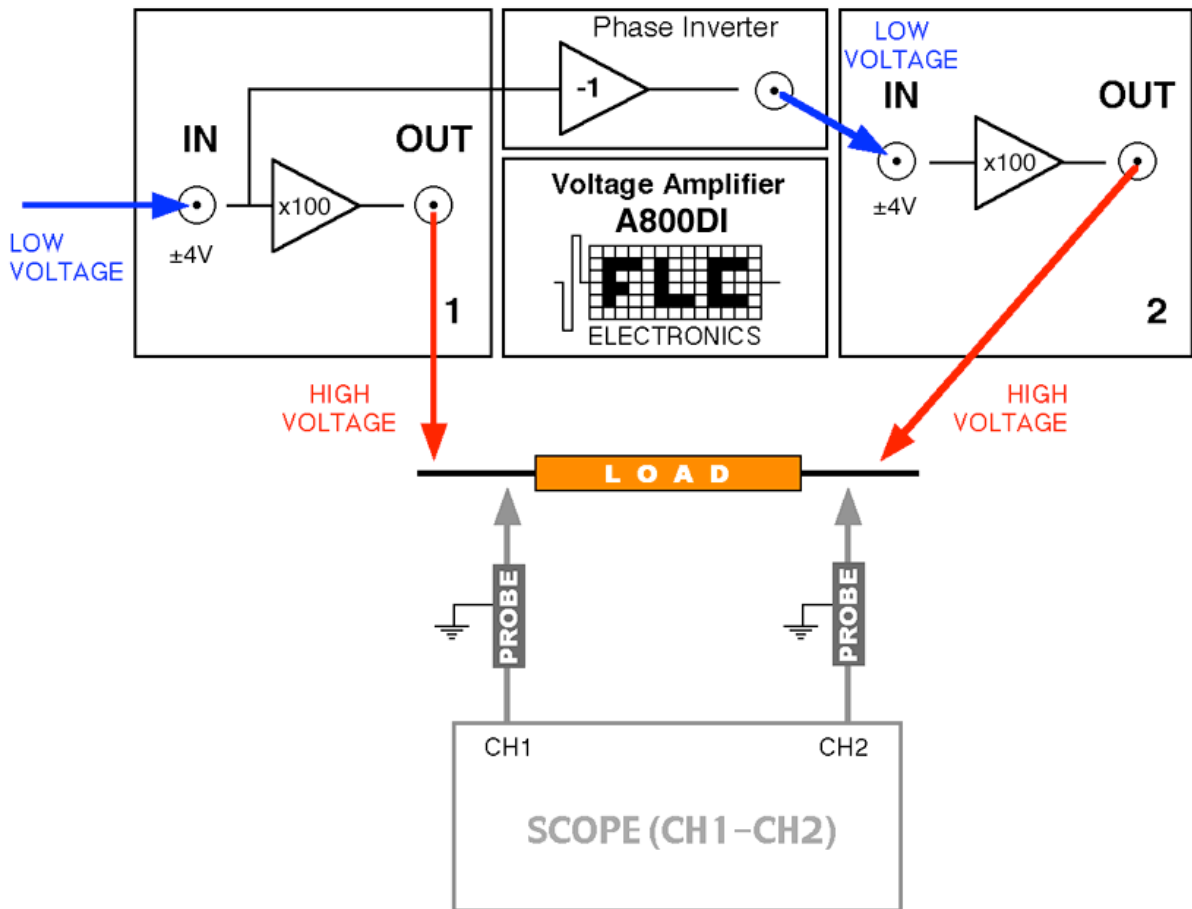

**REMEMBER: There cannot be any connection between the load and ground!**

## LOAD

The amplifier is intended to drive resistive and/or small capacitive loads. The maximum capacitive load depends on the slew rate of the amplifier. The slew rate is normally set at the factory to 500 V/ $\mu$ s which is appropriate for a small load (for example 5 k $\Omega$  in series with 100 pF). Due to the output current limit (60 mA) the slew rate at higher load of 300 pF drops to ca 160 V/ $\mu$ s rising edge and ca 100 V/ $\mu$ s falling edge. This load includes the capacitance of the connection cable (ca 100 pF/m for a standard coaxial cable). Increasing the capacitive load causes overshoot to appear. If a larger capacitive load is required, and the overshoot is not acceptable, then the slew should be reduced accordingly. Such an adjustment may be performed by qualified personnel and the factory should be contacted for advice (preferably by email [service@pendulum-instruments.com](mailto:service@pendulum-instruments.com) ). Inside the cabinet exist hazardous voltage levels and the amplifier circuit is sensitive to static discharge.

Pendulum Instruments recommends to monitor the output signal of the amplifier with an oscilloscope. It is then important to use a low capacitive probe with a division factor of at least 1/100 (please note also the maximum voltage that can be connected to the oscilloscope input and that can be handled by the probe).

Overloading the output may cause an overshoot which might be dangerous for connected devices.

The amplifier cannot be used to drive a purely inductive load.

The continuous output current limit is 60 mA and the output power limit is 30 W (per channel). The output is equipped with a current limiting circuit that withstands accidental short-circuits. Prolonged short-circuiting may result in overheating the amplifier.

The amplifier may be overheated when the output is short-circuited for a long time.

## FREQUENCY RESPONSE

The graph below shows full-scale and small signal frequency responses of **A800DI** without load and with 220 pF pure capacitive load, respectively:

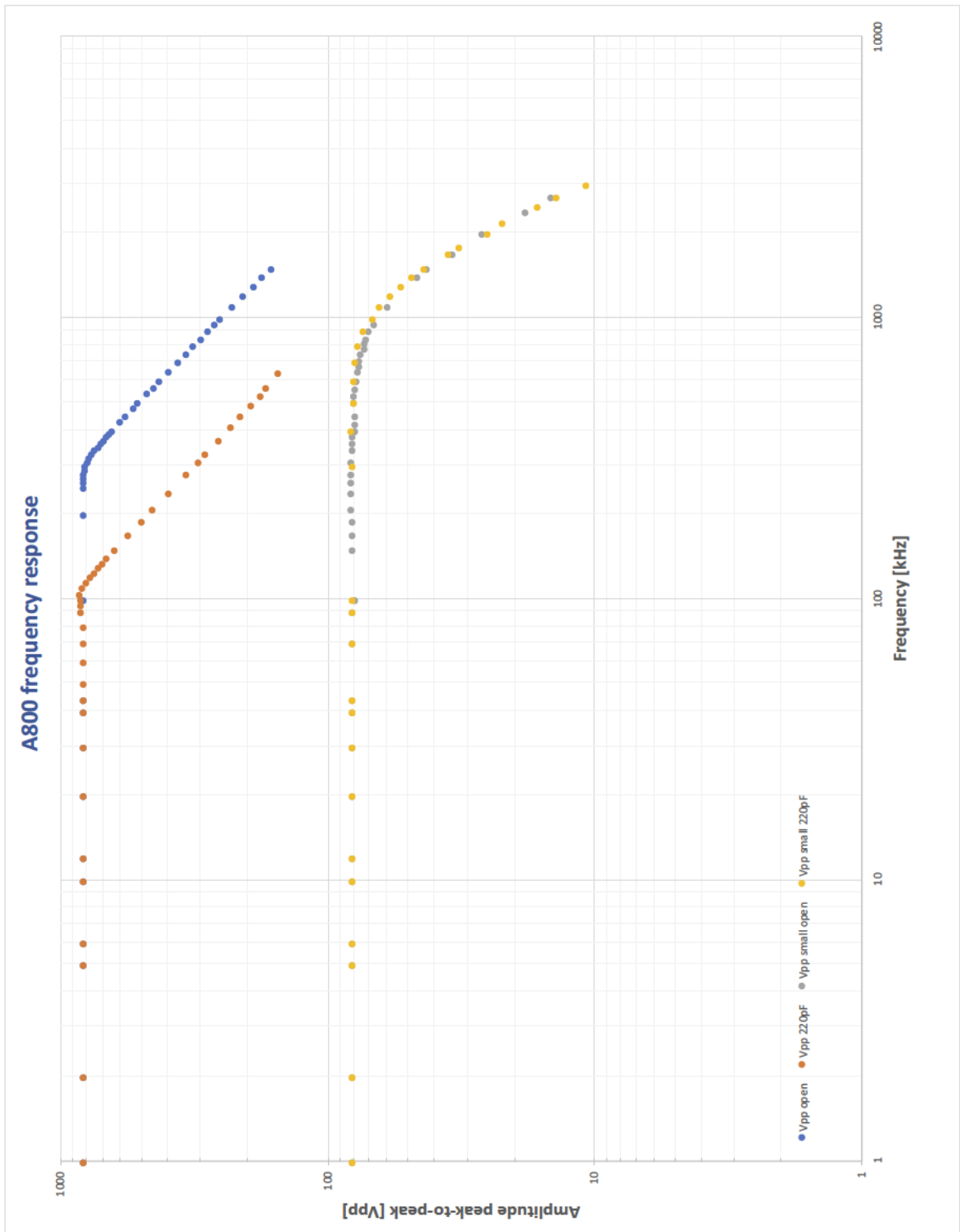

## SUMMARY OF TECHNICAL DATA

<b>Bandwidth:</b>		DC to about 300 kHz at 800 Vpp
<b>Amplification:</b>		100 times
<b>Load:</b>	type	resistive    capacitive
	max	capacitive load 300 pF
<b>Impedance:</b>	input	1 M $\Omega$    30 pF, custom values possible
	output	<0.1 $\Omega$ in the linear mode
<b>Voltage:</b>	input	nominal $\pm 4$ V
<b>Current:</b>	output	maximum 60 mA each channel
<b>Slew Rate:</b>	output	ca 500 V/ $\mu$ s without load (different adjustments available on request)
<b>Input protection fuse</b>		15 mA (Littelfuse, part number 272.015) one spare fuse provided inside the instrument, additional fuses available from Littelfuse resellers or from Pendulum Instruments.
<b>Operating Ambient Temperature:</b>		0°C to 30°C
<b>Storage Temperature:</b>		0°C to 60°C
<b>Relative Humidity:</b>		up to 90% (operation) 30% to 50% (storage)
<b>Power Requirements:</b>		100, 120 or 230 V, 50/60 Hz factory set or 110/220V line voltage selector
<b>Fuse:</b>		2 A (slow)
<b>Dimensions (H/W/L):</b>		112 x 255 x 316 (mm)
<b>Weight:</b>		4 kg
<b>Country of Origin:</b>		Poland

**Note:** Specifications apply to instruments operating at 23°C $\pm$ 5°C ambient temperature after 15 min. warm-up time. Due to ongoing product development, specifications are subject to change without notice.

**WARNING** It is not allowed to connect the 100...230V AC line power input of the amplifier to DC-AC converters or solid state AC generators with non-sinusoidal output.

*Data sheet revision date: 11 October 2019*

## **I M P O R T A N T**



**Inside the amplifier's case exist dangerous voltage levels.**



**The amplifier cannot be used to drive an inductive load.**



**The instrument cannot be powered from a DC-AC converter nor from a solid-state AC generator with non-sinusoidal output.**



**Loads sensitive to voltage transients should be disconnected from the amplifier during power-up and power-down.**



**Never connect the output to the input of the amplifier!**



**The amplifier may be overheated if the output is short-circuited for a long time.**



**It is recommended to monitor the output signal of the amplifier on the oscilloscope.**

## **WARRANTY**

The Warranty Statement is part of the folder *Important Information* that is included with the shipment.

## **DECLARATION OF CONFORMITY**

The complete text with formal statements concerning product identification, manufacturer and standards used for type testing is available on request.

<https://mod-e.ru/>

© Pendulum Instruments 2020  
September 2020  
Specifications subject to change  
or improvements without notice.