

2303, 2304A

High Speed Power Supplies



- Optimized for battery-powered device testing
- Ultra-fast transient response to load changes
- 5A continuous output
- Pulse peak, average, and baseline current measurements
- 100nA DC current sensitivity

MODEL 2304A

- 100W output (20V @ 5A)
- Sinks up to 3A

MODEL 2303

- 45W output (15V @ 3A, 9V @ 5A)
- Sinks up to 2A

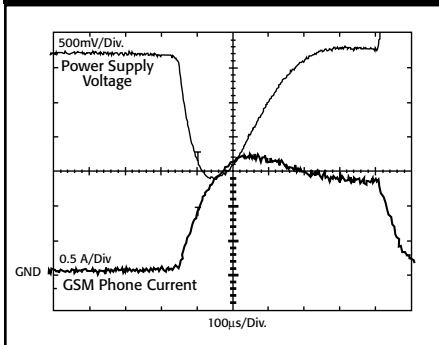

Typical Power Supply. Transient response with 4.5m (15 ft) of cable and 1Ω/lead between source and GSM phone load.



Model 2303 or 2304A rear panel

tery's response during a large load change by minimizing the maximum drop in voltage and recovering to within 100mV of the original voltage in 40µs or less.

When a portable device such as a cellular phone switches from standby mode to the full power mode of operation, the current draw on the power supply can change by as much as 1000%. While a battery's voltage will decrease by the value of the voltage drop across the battery's low internal resistance, a conventional power supply will have a significant voltage drop (more than one volt) and take milliseconds to recover to the original voltage level. For portable devices that operate at full power only for short intervals, the full power event is over before a conventional power supply can recover. For example, cellular phones designed in accordance with the GSM cellular phone standard transmit and receive information in 576µs pulses. If the power supply used to test them cannot recover quickly enough, the performance of the device-under-test will be compromised by the power supply. If the power supply voltage drops below the threshold of the phone's low-battery detection circuitry for a sufficient amount of time, the phone will turn off during testing, giving a false indication of a failed device.

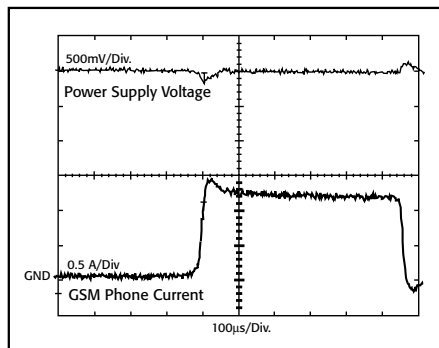

Keithley's High Speed Power Supply. Transient response with 4.5m (15 ft) of cable and 1Ω/lead between source and GSM phone load.

The Model 2303/2304A Power Supplies provide both voltage control and power consumption monitoring for automated testing of portable, battery-operated devices. These power supplies are optimized for testing battery-operated, wireless communication devices such as cellular phones that undergo substantial load changes for very short time intervals. These power supplies exhibit outstanding voltage stability during pulse load changes and can simultaneously measure load currents, even if they are short pulses. In addition, this family of power supplies can sink current and, thus, take on the characteristics of a discharged, rechargeable battery for testing chargers and charger-control circuitry.

5A Output Capacity

Both the 100W Model 2304A and the 45W Model 2303 can supply 5A (at 20V for the Model 2304A and 9V for the Model 2303) to serve the peak pulse loading requirements of battery-operated devices. In both instruments, the maximum current of 5A can be delivered continuously. The Model 2304A can supply up to 20V DC while the Model 2303 can supply up to 15V.

Fast Response to Load Changes

Keithley's High Speed Power Supplies are designed to simulate the current drive capacity of a battery. The power supplies simulate a battery's response during a large load change by minimizing the maximum drop in voltage and recovering to within 100mV of the original voltage in 40µs or less.

The Models 2303/2304A's fast transient response to large load changes will enable test engineers to test their portable products properly and eliminate false failures due to conventional power supplies with slow response times. In this way, the power supplies ensure maximum production throughput when testing portable devices.

1.888.KEITHLEY (U.S. only)

www.keithley.com

A Greater Measure of Confidence

KEITHLEY

A Tektronix Company

2303, 2304A

High Speed Power Supplies

Ordering Information

- 2304A** High Speed Precision Readback Power Supply (100W)
- 2303** High Speed Precision Readback Power Supply (45W)
- 2303-PJ** High Speed Precision Readback Power Supply (45W, 500mA range replaces 5mA range)

Accessories Supplied

User and service manuals,
CS-846 output connectors
mating terminal

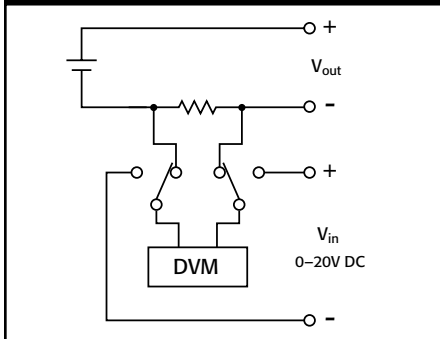

Model 2303/2304A Block Diagram showing DC DVM measurement capability

The Models 2303/2304A perform a continuous integration to make peak, average, and baseline measurements on complex load current waveforms. Integration times can be programmed with 33.3 μ s resolution.

Fast Measurements for Power Consumption Analysis

As manufacturers of portable devices strive to extend battery life and the length of time between recharges, power consumption has become an important performance indicator. Therefore, in production testing, accurate peak power and average power measurements are critical. These measurements are complicated by the fact that wireless telecommunication devices draw full load current in short pulses. The Models 2303/2304A's pulse readback measurement mode makes it possible to capture peak and average values on pulses as short as 60 μ s. This allows the power supply to power a device-under-test and determine its current consumption to qualify the device for its specified power consumption.

In addition to making measurements on short pulses, the 2303/2304A power supplies can measure a current pulse peak or a current pulse train that is as long as 833ms. For random pulse trains that have periods longer than 833ms, the power supplies have a special long integration mode that can make an average current measurement on up to 60s of data. To capture low current pulses from very low power devices, the Model 2303-PJ provides pulse measurement on both the 5A and 500mA ranges.

Accurate Low Current Measurements

The Models 2303/2304A are well-suited for making fast, accurate measurements of sleep and standby mode currents because they are based on Keithley's expertise in low current measurement technologies. With 100nA resolution, the power supplies offer the precision needed to monitor the low sleep mode currents in today's products and in future products. They can also measure these low currents with 0.2% basic accuracy.

High Current Sinking Capacity

Keithley's power supplies can act as an electronic load and sink as much as 3A (Model 2304A)

and 2A (Model 2303), so they can simulate a discharged rechargeable battery. Therefore, they can be used to verify the performance of a portable device's charger. The power supplies' current dissipation capacity allows them to test even high-current fast chargers.

Independent Digital Voltmeter Inputs

While many programmable power supplies offer output readback capabilities, Keithley's power supplies are the only instruments available that also offer a set of DVM inputs. These inputs allow the Model 2304A to measure signals from 0 to +20V (0 to +15V for the Model 2303) anywhere in the test system with the same rated accuracy as the voltage readback. The DVM and the power source can operate simultaneously. For many applications, the power supplies' built-in DVM eliminates the expense and space that a separate voltage measurement instrument would require.

Remote Display Option

If the Model 2303 or 2304A must be mounted in a location in which the display is not readily visible, an optional Model 2304-DISP Display Module can be mounted at a more convenient point, then plugged into the power supply unit. The display module also includes all instrument controls, so that the power supply can be operated remotely from the more accessible location.

ACCESSORIES AVAILABLE

2304-DISP	Remote Display
CS-846	Mating Output Connector

CABLES

7007-1	Shielded IEEE-488 Cable, 1m (3.3 ft)
7007-2	Shielded IEEE-488 Cable, 2m (6.6 ft)
SC-182	Low-Inductance Coaxial Cable (42nH/ft)

RACK MOUNT KITS

4288-1	Single Fixed Rack Mount Kit
4288-2	Dual Fixed Rack Mount Kit

IEEE-488 INTERFACES

KPCI-488LPA	IEEE-488 Interface/Controller for the PCI Bus
KUSB-488B	IEEE-488 USB-to-GPIB Interface Adapter

SERVICES AVAILABLE

2303-3Y-EW	1-year factory warranty extended to 3 years from date of shipment
2303-PJ-3Y-EW	1-year factory warranty extended to 3 years from date of shipment
2304A-3Y-EW	1-year factory warranty extended to 3 years from date of shipment
C/2303-3Y-ISO	3 (ISO-17025 accredited) calibrations within 3 years of purchase for Models 2303, 2303-PJ*
C/2304A-3Y-ISO	3 (ISO-17025 accredited) calibrations within 3 years of purchase for Model 2304A*

*Not available in all countries

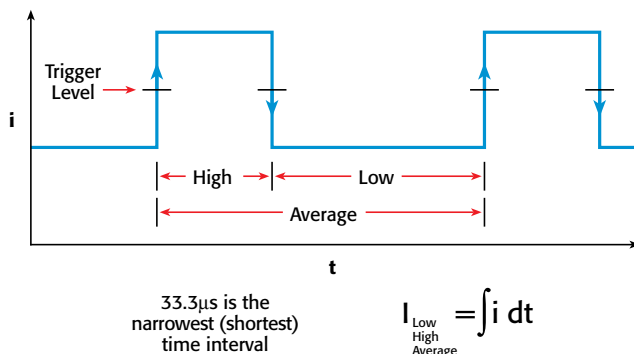

1.888.KEITHLEY (U.S. only)

www.keithley.com

DC Voltage Output (2 Years, 23°C ± 5°C)

OUTPUT VOLTAGE: 0 to +15V DC.
 OUTPUT ACCURACY: ±(0.05% + 10mV).
 PROGRAMMING RESOLUTION: 5mV.
 READBACK ACCURACY¹: ±(0.05% + 3mV).
 READBACK RESOLUTION: 1mV.
 OUTPUT VOLTAGE SETTling TIME: 5ms to within stated accuracy.
 LOAD REGULATION: 0.01% + 2mV.
 LINE REGULATION: 0.5mV.
 STABILITY²: 0.01% + 0.5mV.
 TRANSIENT RESPONSE TO 1000% LOAD CHANGE:
 Transient Recovery Time^{3,4}: <40μs to within 100mV of previous level.
 <80μs to within 20mV of previous level.
 Transient Voltage Drop: <100mV, typical.³
 <200mV, typical.⁴
 RIPPLE AND NOISE (20Hz to 20MHz): 3mV rms/8mV p-p, typical.
 REMOTE SENSE: Automatic 1V max. drop in each lead. Add 2mV to the voltage load regulation specification for each 1V change in the negative output lead due to load current change.

DC Current (2 Years, 23°C ± 5°C)

OUTPUT CURRENT: 0–9V: 5A max. >9V–15V: 3A max. (not intended to be operated in parallel).
 SOURCE COMPLIANCE ACCURACY: ±(0.16% + 5mA)⁵
 PROGRAMMED SOURCE COMPLIANCE RESOLUTION: 1.25mA.
 READBACK ACCURACY
 2303: 5A range: ±(0.2% + 400μA). 5mA range: ±(0.2% + 1μA).
 2303-PJ: 5A range: ±(0.2% + 400μA). 500mA range: ±(0.2% + 40μA).
 READBACK RESOLUTION
 2303: 5A range: 100μA. 5mA range: 0.1μA.
 2303-PJ: 5A range: 100μA. 500mA range: 10μA.
 CURRENT SINK CAPACITY: 0–5V: 2A max. 5V–15V: Derate 0.1A per volt above 5V.
 LOAD REGULATION: 0.01% + 1mA.
 LINE REGULATION: 0.5mA.
 STABILITY²: 0.01% + 50μA.

Digital Voltmeter Input (2 Years, 23°C ± 5°C)

INPUT VOLTAGE RANGE: 0 to +20V DC.
 INPUT IMPEDANCE: 10¹⁰Ω typical.
 MAXIMUM VOLTAGE (either input terminal) WITH RESPECT TO OUTPUT LOW: –3V, +22V.
 READING ACCURACY¹: ±(0.05% + 3mV).
 READING RESOLUTION: 1mV.

NOTES

- ¹ PLC = 1.00.
- ² Following 15 minute warm-up, the change in output over 8 hours under ambient temperature, constant load, and line operating conditions.
- ³ Remote sense, at output terminals, 1000% load change; typical.
- ⁴ Remote sense, with 4.5m (15 ft) of 16 gauge wire and 1Ω resistance in each source lead to simulate typical test environment, up to 1.5A load change.
- ⁵ Minimum current in constant current mode is 6mA.
- ⁶ 60Hz (50Hz).
- ⁷ PLC = Power Line Cycle. 1PLC = 16.7ms for 60Hz operation, 20ms for 50Hz operation.
- ⁸ Display off.
- ⁹ Speed includes measurement and binary data transfer out of GPIB.

DC General

MEASUREMENT TIME CHOICES: 0.01 to 10 PLC⁷, in 0.01PLC steps.
 AVERAGE READINGS: 1 to 10.
 READING TIME ^{1,8,9}: 31ms, typical.

Pulse Current Measurement Operation

TRIGGER LEVEL:
 2303: 5mA to 5A, in 5mA steps.
 2303-PJ: 5A Range: 0mA to 5A, in 5mA steps.
 500mA Range: 0mA to 500mA, in 0.5mA steps.
 TRIGGER DELAY: 0 to 100ms, in 10μs steps.
 INTERNAL TRIGGER DELAY: 25μs.
 HIGH/LOW/AVERAGE MODE:
 Measurement Aperture Settings: 33.3μs to 833ms, in 33.3μs steps.
 Average Readings: 1 to 100.
 BURST MODE:
 Measurement Aperture: 33.3μs.
 Conversion Rate: 3600/second, typical.
 Number of Samples: 1 to 5000.
 Transfer Samples Across IEEE Bus in Binary Mode: 4800 bytes/second, typical.
 LONG INTEGRATION MODE: Measurement Time⁶: 850ms (840ms) to 60 seconds in 16.7ms (20ms) steps.

GENERAL

ISOLATION (low-earth): 22V DC max.
 PROGRAMMING: IEEE-488.2 (SCPI).
 USER-DEFINABLE POWER-UP STATES: 5.
 REAR PANEL CONNECTOR: 8-position quick disconnect terminal block for output (4), sense (2), and DVM (2).
 TEMPERATURE COEFFICIENT (outside 23°C ± 5°C): Derate accuracy specification by (0.1 × specification)/°C.
 OPERATING TEMPERATURE:
 0° to 35°C (Full power).
 0° to 50°C (Derate to 70%).
 STORAGE TEMPERATURE: –20° to 70°C.
 HUMIDITY: <80% @ 35°C non-condensing.
 POWER CONSUMPTION: 150VA max.
 REMOTE DISPLAY/KEYPAD OPTION: Disables standard front panel.
 DIMENSIONS: 89mm high × 213mm wide × 360mm deep (3½ in × 8½ in × 14¾ in).
 SHIPPING WEIGHT: 5.4kg (12 lbs).
 INPUT POWER: 100V–120VAC/220–240VAC, 50 or 60Hz (auto detected at power-up).
 EMC: Conforms with European Union Directive directive 89/336/EEC EN 55011, EN 50082-1, EN 61000-3-2, and 61000-3-3, FCC part 15 class B.
 SAFETY: Conforms with European Union Directive 73/23/EEC EN 61010-1, UL 3111-1.
 AC LINE LEAKAGE CURRENT: 450μA @ 110VAC, typ.; 600μA @ 220VAC, typ.
 RELAY CONTROL JACK: 1-channel, sink 150mA max., 15V max. 5V output, 100mA max., also available on jack. Accepts 0.173 in Bantam-type plug (CS-1003-1).

2304A

High Speed Power Supply

Model 2304A specifications

DC POWER SUPPLIES

DC Voltage Output (1 Year, 23°C ± 5°C)

OUTPUT VOLTAGE:

- 0 to +20V DC (for Normal Output Response).
- 0 to +15V DC (for Enhanced Output Response).

OUTPUT ACCURACY: $\pm(0.05\% + 10\text{mV})$.

PROGRAMMING RESOLUTION: 5mV.

READBACK ACCURACY¹: $\pm(0.05\% + 10\text{mV})$.

READBACK RESOLUTION: 1mV.

OUTPUT VOLTAGE SETTling TIME: 5ms to within stated accuracy.

LOAD REGULATION: 0.01% + 2mV.

LINE REGULATION: 0.5mV.

STABILITY²: 0.01% + 0.5mV.

TRANSIENT RESPONSE TO 1000% LOAD CHANGE:

NORMAL MODE:

- Transient Recovery Time³: <50 μs to within 100mV of previous level.
<100 μs to within 20mV of previous level.

ENHANCED MODE:

- Transient Recovery Time^{3,4}: <40 μs to within 100mV of previous level.
<80 μs to within 20mV of previous level.

- Transient Voltage Drop: <100mV, typical.³
<200mV, typical.⁴

REMOTE SENSE: Automatic, 2V max. drop in each lead. Add 2mV to the voltage load regulation specification for each 1V change in the negative output lead due to load current change.

DC Current (1 Year, 23°C ± 5°C)

OUTPUT CURRENT: 5A max. (not intended to be operated in parallel).

COMPLIANCE ACCURACY: $\pm(0.16\% + 5\text{mA})$ ⁵.

PROGRAMMED COMPLIANCE RESOLUTION: 1.25mA.

READBACK ACCURACY¹

- 5A range: $\pm(0.2\% + 1\text{mA})$. 5mA range: $\pm(0.2\% + 1\mu\text{A})$.

READBACK RESOLUTION

- 5A range: 100 μA . 5mA range: 0.1 μA .

CURRENT SINK CAPACITY:

- 3A max. (for Normal Output Response).
- 1A⁶ (for Enhanced Output Response).

LOAD REGULATION: 0.01% + 1mA.

LINE REGULATION: 0.5mA.

STABILITY²: 0.01% + 50 μA .

Digital Voltmeter Input (1 Year, 23°C ± 5°C)

INPUT VOLTAGE RANGE: 0 to +20V DC.

INPUT IMPEDANCE: 10¹⁰ Ω typical.

MAXIMUM VOLTAGE (either input terminal) WITH RESPECT TO OUTPUT LOW: -3V, +22V.

READING ACCURACY²: $\pm(0.05\% + 10\text{mV})$.

READING RESOLUTION: 1mV.

NOTES

¹ PLC = 1.00.

² Following 15 minute warm-up, the change in output over 8 hours under ambient temperature, constant load, and line operating conditions.

³ Remote sense, at output terminals, 1000% load change; typical.

⁴ Remote sense, with 4.5m (15 ft) of 16 gauge wire and 1 Ω resistance in each lead to simulate typical test environment, up to 1.5A load change.

⁵ Minimum current in constant current mode is 6mA.

⁶ 15W typical. 0°–35°C. Derate 1W/°C up to 50°C.

⁷ PLC = Power Line Cycle. 1PLC = 16.7ms for 60Hz operation, 20ms for 50Hz operation.

⁸ Display off.

⁹ Speed includes measurement and binary data transfer out of GPIB.

¹⁰ Max. continuous.

¹¹ 60Hz (50Hz).

DC General

MEASUREMENT TIME CHOICES: 0.01 to 10 PLC⁷, in 0.01PLC steps.

AVERAGE READINGS: 1 to 10.

READING TIME^{1,8,9}: 31ms, typical.

PULSE CURRENT MEASUREMENT OPERATION

TRIGGER LEVEL: 5mA to 5A, in 5mA steps.

TRIGGER DELAY: 0 to 100ms, in 10 μs steps.

INTERNAL TRIGGER DELAY: 25 μs .

HIGH/LOW/AVERAGE MODE:

Measurement Aperture Settings: 33.3 μs to 833ms, in 33.3 μs steps.

Average Readings: 1 to 100.

BURST MODE:

Measurement Aperture: 33.3 μs .

Conversion Rate: 3600/second, typical.

Number of Samples: 1 to 5000.

Transfer Samples Across IEEE Bus in Binary Mode: 4800 bytes/second, typical.

LONG INTEGRATION MODE¹¹: Measurement Time: 850ms (840ms) to 60 seconds in 16.7ms (20ms) steps.

GENERAL

ISOLATION (low-earth): 22V DC max.

PROGRAMMING: IEEE-488.2 (SCPI).

USER-DEFINABLE POWER-UP STATES: 5.

REAR PANEL CONNECTOR: 8-position quick disconnect terminal block for output (4), sense (2), and DVM (2).

RELAY CONTROL JACK: 2-channel, sink 150mA max., 15V max. Accepts 0.173 in. Bantam-type plug (CS-1003-1).

TEMPERATURE COEFFICIENT (outside 23°C ± 5°C): Derate accuracy specification by (0.1 × specification)/°C.

OPERATING TEMPERATURE:

- 0° to 50°C (50W¹⁰ normal response, 25W¹⁰ enhanced response).
- 0° to 35°C (100W¹⁰ normal response, 75W¹⁰ enhanced response).

STORAGE TEMPERATURE: -20° to 70°C.

HUMIDITY: <80% @ 35°C non-condensing.

POWER CONSUMPTION: 200VA max.

REMOTE DISPLAY/KEYPAD OPTION: Disables standard front panel.

DIMENSIONS: 89mm high × 213mm wide × 360mm deep (3½ in × 8½ in × 14¾ in).

SHIPPING WEIGHT: 5.4kg (12 lbs).

INPUT POWER: 100V–240V AC, 50 or 60Hz (auto detected at power-up).

EMC: Conforms with European Union Directive 89/336/EEC EN 55011, EN 50082-1, EN 61000-3-2, and 61000-3-3, FCC part 15 class B.

SAFETY: Conforms with European Union Directive 73/23/EEC EN 61010-1.

1.888.KEITHLEY (U.S. only)

www.keithley.com

A Greater Measure of Confidence

KEITHLEY
A Tektronix Company