



Frequency Distribution Amplifier FDA-301A

USER MANUAL



Part No.: 4031.604.66041
Revision: 1
Date: 18.04.2023

GENERAL INFORMATION

About this Manual

This manual contains instructions on how to install and use the FDA-301A Frequency Distribution Amplifier.

Warranty

The Warranty Statement is part of the folder Important Information that is included with the shipment.

Declaration of Conformity

The complete text with formal statements concerning product identification, manufacturer and standards used for type testing is available on request.

PREFACE

Introduction

Congratulations on your choice of instrument. It will serve you well for many years to come. Your instrument is designed to bring you the most efficient way of distributing a reference frequency and pulsed signals. It gives significantly increased performance compared to traditional Distributors of signals. The FDA-301A offers the following advantages:

- Multiple signal types:
 - Low noise sine wave (default 10MHz)
 - Timing reference signals, 1-pps and IRIG DCLS
 - Serial ToD
- Distribution via optical fiber or electrical coax
- No noise pick-up, no ground current loops and up to 2km range using fiber
- Three modular output boards providing up to 12 coax, or 18 fiber outputs
- Power source redundancy: AC and optional DC power

Powerful and Versatile Functions

A unique feature of your new instrument is modularity. The output signal cards are interchangeable, which allows for any configuration chosen by the user without the need to send the instrument to the manufacturer. One of the advantages of distribution via fiber is transmission to remote sites, over long distances, up to 2 km.

PREPARATION FOR USE

Safety

Introduction

Please take a few minutes to read through this part of the introductory chapter carefully before plugging the power cable into the wall outlet. This instrument has been designed and tested for Measurement Category I, Pollution Degree 2, in accordance with EN 61010-1:2011 and EN 61326

:2013, increased test levels according to EN 61000-6-2:2008, Group 1, class B, CE. It has been supplied in a safe condition. Study this manual thoroughly to acquire adequate knowledge of the instrument, especially the section on Safety Precautions hereafter and the section on Installation on next pages.

Safety Precautions

All equipment that can be connected to line power is a potential danger to life. Handling restrictions imposed on such equipment should be observed. To ensure the correct and safe operation of the instrument, it is essential that you follow generally accepted safety procedures in addition to the safety precautions specified in this manual. The instrument is designed to be used by trained personnel only. Removing the cover for repair, maintenance, and adjustment of the instrument must be done by qualified personnel who are aware of the hazards involved.

The warranty commitments are rendered void if unauthorized access to the interior of the instrument has taken place during the given warranty period.

Caution and Warning Statements

CAUTION: Shows where incorrect procedures can cause damage to, or destruction of equipment or other property.

WARNING: Shows a potential danger that requires correct procedures or practices to prevent personal injury.



Shows where the protective ground terminal is connected inside the instrument.

Never remove or loosen this screw.



This symbol is used for identifying the functional ground of an I/O signal. It is always connected to the instrument chassis.

If in Doubt about Safety

Whenever you suspect that it is unsafe to use the instrument, you must make it inoperative by doing the following:

- Disconnect the line cord
- Clearly mark the instrument to prevent its further operation
- Inform your Pendulum-Instruments representative.

For example, the instrument is likely to be unsafe if it is visibly damaged.

Environmental Considerations

This section provides information about the environmental impact of the product.

Product End-of-Life Handling

Observe the following guidelines when recycling an instrument or component:

Equipment recycling

Production of this equipment required the extraction and use of natural resources. The equipment may contain substances that could be harmful to the environment or human health if improperly handled at the product's end of life. To avoid release of such substances into the environment and to reduce the use of natural resources, we encourage you to recycle this product in an appropriate system that will ensure that most of the materials are reused or recycled appropriately.

 This symbol indicates that this product complies with European Union requirements according to Directives 2012/19/EU and 2006/66/EC on waste electrical and electronic equipment (WEEE) and batteries.

Batteries

This product does not contain any built-in battery

Unpacking

Check that the shipment is complete and that no damage has occurred during transportation. If the contents are incomplete or damaged, file a claim with the carrier immediately. Also notify your local Pendulum sales or service organization in case repair or replacement may be required.

Check list

The shipment should contain the following:

- FDA-301A with options installed according to your ordered configuration
- Line cord
- Important Information fact sheet
- Certificate of Calibration
- CD including the following documentation in PDF format:
 - User's Manual

The actual configuration of your ordered instruments is readable from the last 5 digits in the "NC" field of the product label on the rear panel.

NC: 9446 130 XYZZZ

X = Input options

Y = Power options

Z = Output options (3 slots)

X=1: 10 MHz only (std)

X=2: 10 MHz, pulse

X=3: 10 MHz, ToD

X=5: 10 MHz, pulse + ToD

Y=1: AC power

Y=2: AC + DC power

Z=0: module not installed

Z=1: 4x10 MHz coax

Z=2: 6x10 MHz fiber

Z=3: 4x pulse coax

Z=4: 6x pulse fiber

Z=5: 4x ToD electrical

Example: NC = 9446 130 11021 = FDA-301A with 10 MHz input only (X), no DC option (Y) plus one empty output slot, one 6x 10 MHz fiber output, and one 4x 10 MHz coax output (ZZZ).

Installation

Type number and Serial number

The products type number label, including the configuration (NC) and the serial number (SN), is the best way for Pendulum Instruments to identify the product. If the serial number is not noted on your delivery notes, please add the serial number to your own product documentation. This will be useful at future contact with Pendulum Instruments.

Supply Voltage

Setting

The Frequency Distribution Amplifier may be connected to any AC supply with a voltage rating of 90 to 265 Vrms, 45 to 63Hz. The Frequency Distribution Amplifier automatically adjusts itself to the input line voltage.

Fuse

The secondary supply voltages are electronically protected against overload or short circuit. The primary line voltage side is protected by a fuse located on the power supply unit. The fuse rating covers the full voltage range. Consequently there is no need for the user to replace the fuse under any operating conditions, nor is it accessible from the outside.

CAUTION: If this fuse is blown, it is likely that the power supply is badly damaged. Do not replace the fuse. Send the Frequency Distribution Amplifier to the local Service Center.

Removing the cover for repair, maintenance and adjustment must be done by qualified and trained personnel only, who are fully aware of the hazards involved.

The warranty commitments are rendered void if unauthorized access to the interior of the instrument has taken place during the given warranty period.

Grounding

 Grounding faults in the line voltage supply will make any instrument connected to it dangerous. Before connecting any unit to the power line, you must make sure that the protective ground functions correctly. Only then can a unit be connected to the power line and only by using a three-wire line cord. No other method of grounding is permitted. Extension cords must always have a protective ground conductor.

CAUTION: If a unit is moved from a cold to a warm environment, condensation may cause a shock hazard. Ensure, therefore, that the grounding requirements are strictly met.

WARNING: Never interrupt the grounding cord. Any interruption of the protective ground connection inside or outside the instrument or disconnection of the protective ground terminal is likely to make the instrument dangerous.

Power switch

There is no power switch in this Distribution Amplifier. The unit is automatically powered when connected to an AC source. It is also automatically powered when connected to a DC source, when option 49 is installed.

Orientation and Cooling

The Frequency Distribution Amplifier can be operated in any position desired. Make sure that the air flow through the ventilation slots at the side panels is not obstructed. Leave 5 centimeters (2 inches) of space around the unit.

Fold-Down Support

For bench-top use, a fold-down support is available for use underneath the counter.

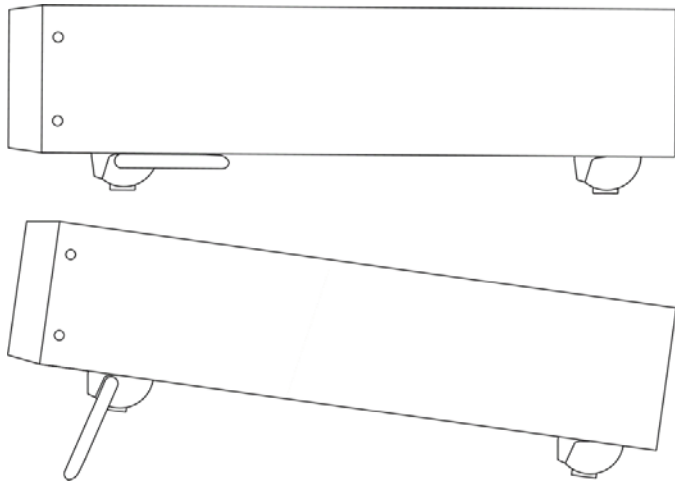

Rackmount Adapter – one instrument (Option 22/90)

This rackmount adapter can hold any standard Pendulum ½ * 19” unit, like FDA-301A, CNT-9x, GPS-12x etc.

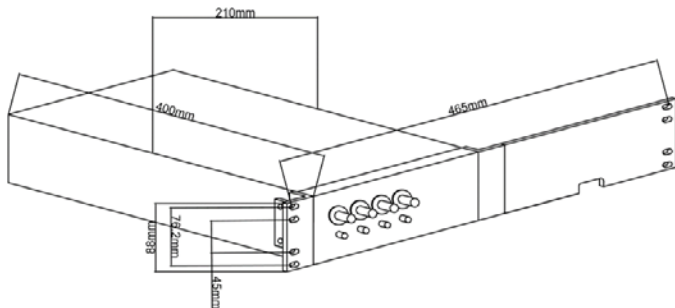

If you have ordered the Option 22/90, 19-inch rack-mount kit for one instrument, it has to be assembled after delivery of the instrument.

The rackmount kit consists of the following:

- 2 brackets, (short, left; long, right)
- 4 screws, M5x8
- 4 screws, M6x8

Assembling the Rackmount Kit (Option 22/90)

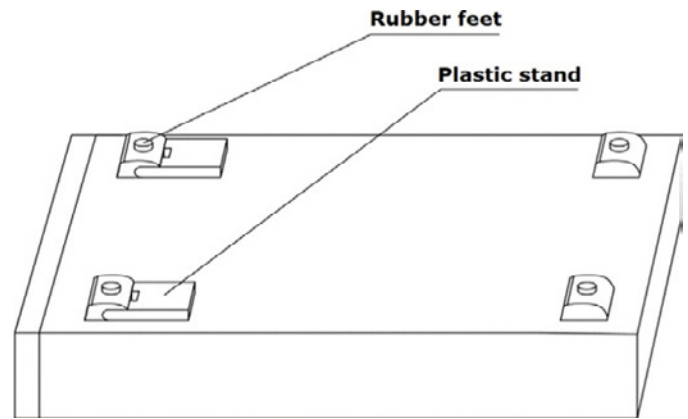

- Turn the device upside down
- Remove the rubber feet in the plastic stand
- Loosen the screws underneath the rubber feet
- Remove the plastic stands
- Remove the four decorative plugs that cover the screw holes on the right and left side of the front panel.
- The long bracket in Option 22/90 has an opening so that cables for Input signals can be routed inside the rack.
- Mount the rackmount kit with the included screws

Reversing the Rackmount Kit

The instrument may also be mounted to the right in the rack. To do so, swap the position of the two brackets.

Rackmount Adapter – two instruments (Option 22/05)

This rackmount adapter can hold any two standard Pendulum ½ * 19” unit, like FDA-301A, CNT-9x, GPS-12x etc.

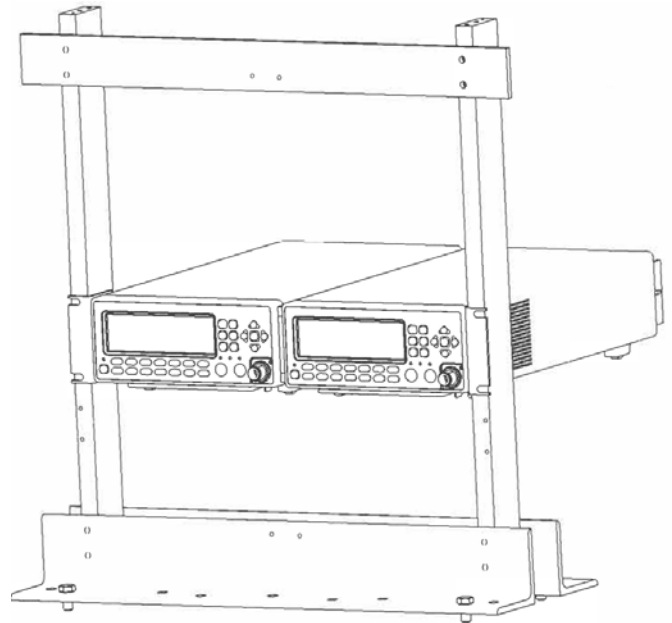

If you have ordered the Option 22/05 rack-mount kit for two instruments, it has to be also assembled after delivery of the instrument. The rackmount kit consists of the following:

- 4 Brackets, rear
- 1 Hinge Spring Latch

- 2 Ear, rack
- 1 Assembly instruction, SXS Rack kit
- 2 Screws M4x8
- 8 Screws M5x10
- 1 Spacer M4x16

Assembling the Rackmount Kit (Option 22/05)

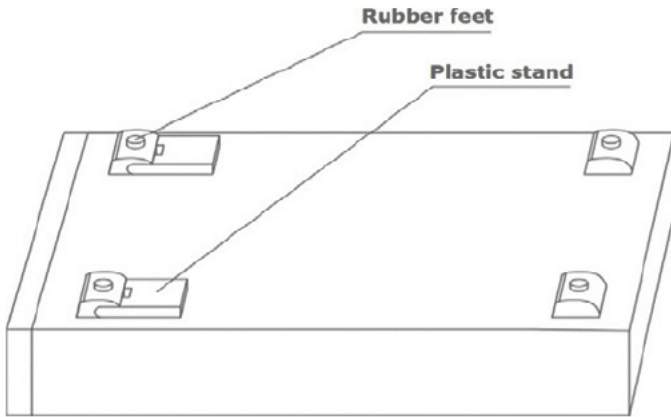

- Turn the devices upside down
- Remove the rubber feet in the plastic stand
- Loosen the screws underneath the rubber feet
- Remove the plastic stands
- Remove the four decorative plugs that cover the screw holes on the right and left side of the front panel.

Use the following steps to complete the side by side rack mount installation for your products. If necessary, refer to the item numbers in the following diagram for additional detail.

- Determine where you would like each unit positioned (i.e., on the right or left side)
- If plugs exist on the mounting holes on the front left and right side of product cover, remove and discard them
- Using screwdriver, screw the rack ear (Item #2) into place using the supplied 10mm screws (Item #5)
- Pinch the hinge pins together to separate the right and left hinge halves (Items #3 and 4)
- Attach hinge halves to the unit with hinge facing towards the front (as displayed in diagram)
- Using a screwdriver, remove the existing rear brackets on the back of each unit
- Using existing machine screws removed in previous steps, attach the rear brackets supplied with the mounting kit (Item #1)
- Pinch the hinge pins together into the stored position. Align the hinge halves together between the two units, and swing together side by side. The hinge pins should snap into place securing the front of the two units together
- Take the supplied Hex Spacer (Item #7) and place between middle rear brackets, and secure using the supplied 8mm screws (Item #6)
- Assembly is now ready for installation into standard 19" rack

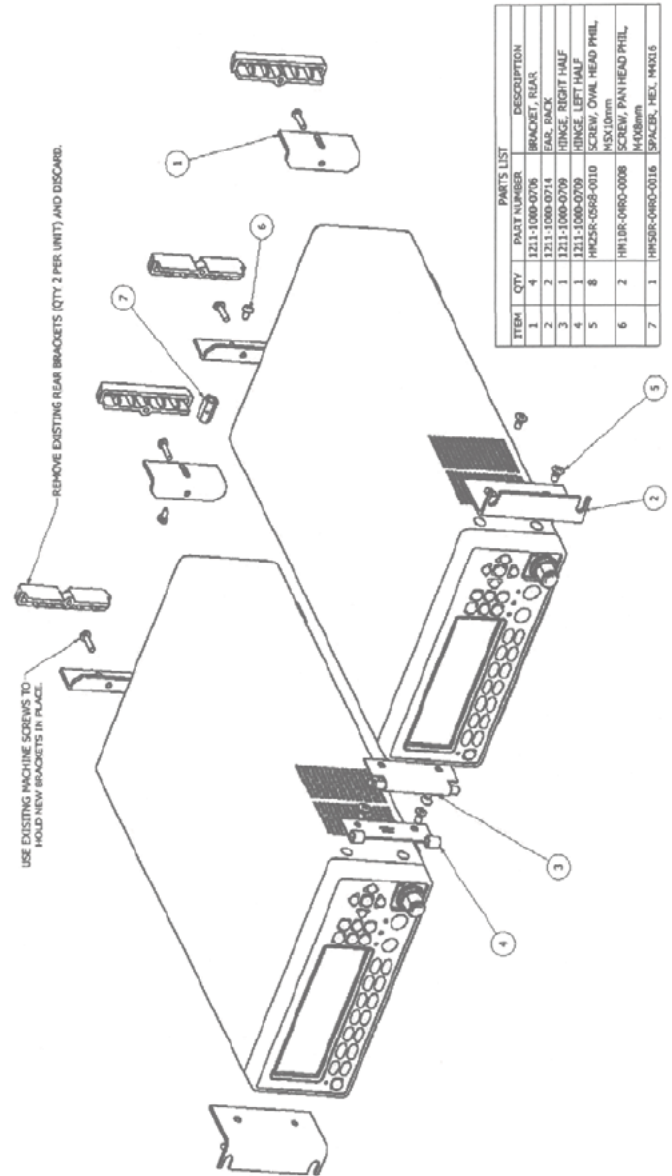

ITEM	QTY	PART NUMBER	DESCRIPTION
1	4	1211-1000-0706	BRACKET, REAR
2	2	1211-1000-0714	EAR, RACK
3	1	1211-1000-0709	HINGE, RIGHT HALF
4	1	1211-1000-0709	HINGE, LEFT HALF
5	8	PHCSK-0265-0110	SCREW, OVAL HEAD PHIL. M4X8mm
6	2	PH10R-0060-0008	SCREW, PAN HEAD PHIL. M4X8mm
7	1	PHSSR-0060-0116	SPACER, HEX. M4X16

USING THE CONTROLS

The purpose of the Frequency Distribution Amplifier is to distribute a stable reference signal, or a timing/synchronization signal, from the source to one or more remote receivers. It can also act as an Electrical-to-Optical signal converter or Optical-to-Electrical converter

The operation of the Frequency Distribution Amplifier is extremely simple. There are no settings controls whatsoever on the FDA-301A, not even a power switch. The operation is truly plug-and-play. Just plug in the FDA-301A to the mains power, and connect your input source – coax or fiber – to the relevant input connector.

Front Panel – Inputs

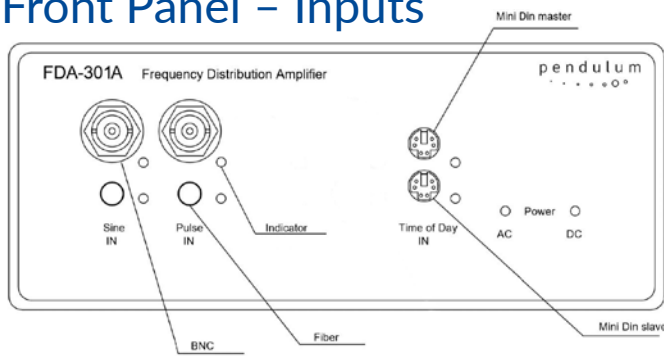

Every signal type input has dual connectors, one BNC coax connector on top, for connecting an electrical signal, and an ST-fiber connector below for connecting an optical signal. The ToD input has two identical 6-pole mini-DIN connectors.

Your actual configuration depends on the ordered options. Non-ordered options will have a plastic cap at their front panel position, stating “Option not installed”

LED – status

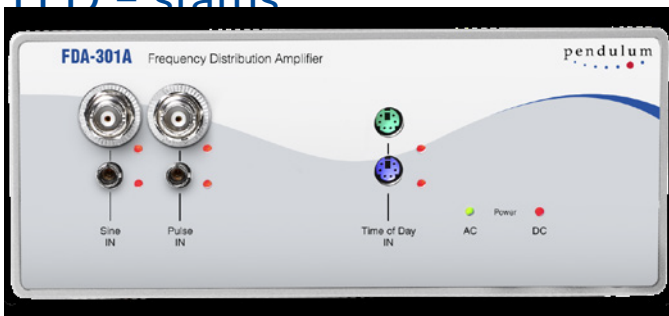

LED indicators are located on the front panel of the instrument. They can individually take the state of red or green.

Green input LED indicates that the input has detected a signal within the input limits. Signal is good.

Red input LED indicates that the input signal is outside the input limits, as when there is no signal attached. Red also indicates that the signal path for this input is blocked.

The Power indicators show the status of the power supplies. If DC power supply option is not installed, that LED is always Red. If LED's are turned off/black, there is no power supplied to the

FDA-301A.

Note that the Input Status indicators do not evaluate the quality of the input signals, only the amplitude.

Rear Panel – Outputs

The rear panel contains three slots for up to three output modules, the AC input power connector, and the +24V DC input power connector (if option 49 is installed).

The example below shows one mounted 10MHz coax output signal module, and two unused slots. If you want to use more modules, you must remove the sticker on the rear panel, carefully insert a new module into the slot using the guide rails, and fasten with the included screws. It does not matter in which position the modules are inserted.

The output modules could be for the same signal type, e.g. sine, or for different signal types, distributed in parallel, e.g. sine AND pulse.

The output modules could be a mix of fiber or coax outputs

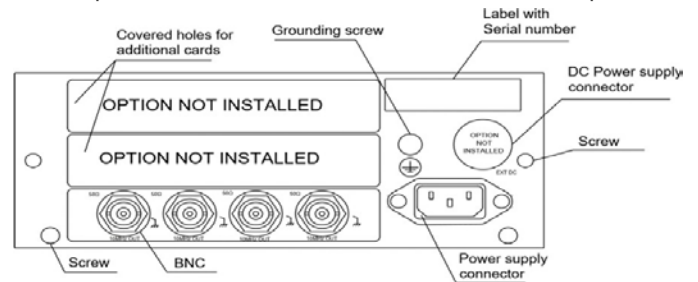

Signal types

Sine

The Sine input channel is intended for narrowband reference frequency distribution. The signal path is bandpass filtered to reject frequencies other than the desired.

The default sine frequency is 10 MHz, but FDA-301A could be modified to distribute other common reference frequencies instead, from 100 kHz to 60 MHz. Please contact Pendulum Instrument about desired frequency, before ordering.

The input signal range is from 0.2 to 2Vrms, and the output signal level is 1Vrms nominal into 50 ohm.

Pulse

The Pulse input channel is intended for distribution of broadband timing reference or synchronization pulses from 1 Hz to 20 MHz.

Example of timing reference pulse signals are 1-pps and IRIG (DCLS). The input and output signal range is TTL-levels into 50 ohm

Time of Day

The Time of Day (ToD) channel is intended to distribute time code messages, e.g. in NMEA format, to multiple users over RS-232.

The connectors are of Mini Din type, 6 pins Female. Unlike the other signal types, there is no long range fiber distribution

Pin number of connector:

- 1: Reserved
- 2: Reserved
- 3: Electrical ground
- 4: NC
- 5: Electrical ground
- 6: Message input (level RS232C, ASCII message)

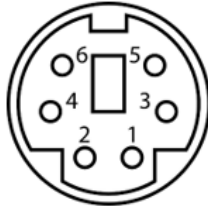

Start and Usage

Power on

Connect the power supply to the instrument using the included power cord. Allow FDA-301A to warm-up for some minutes. Wait to connect fiber or coax signal to the inputs until Input Status indicators are red.

The unit should normally always be continuously powered. The only instance when power should be disconnected is when adding or replacing output modules.

Input signals can be added, removed or changed without any power off.

Input source redundancy with auto-changeover

The FDA-301A can be configured for automatic change-over of the input source. Then the Master reference shall be connected to the lower fiber port, and the Slave reference to the upper coax port.

As long as both inputs signals are valid, and the coax and fiber LED's are green at the same time, the fiber input has priority and is used for distribution. The coax input signal path is internally blocked. If the Master reference should fail, the Slave reference at the BNC-input automatically takes over.

If valid ToD signal levels are detected at both ToD input connectors, meaning both LEDs are Green, then the lower input will be used and the signal path of the upper connector is internally blocked.

Power supply redundancy with auto-changeover

When the DC power supply option, Option 49, is installed and connected to +24V, the FDA-301A is set-up for automatic change-over of the power source. Normally, the internal secondary power voltages are generated from the AC supply, but in the case of a power line failure, the DC supply option automatically takes over. When the power line is restored, then internal power via the AC supply is resumed.

Configuration examples

There are no parameters to be configured or set.

The FDA-301A can be used in many distribution situations. For example:

- Local Coax distribution (coax in – coax out) to up to 12 users (1 FDA-unit)
- Remote Coax distribution (coax in/fiber out – fiber in/coax out) to up to 216 users (multiple FDA-units)
- Electrical to Optical conversion and splitting

- Optical to Electrical conversion and splitting
- ToD distribution to multiple users

Some typical examples of possible distribution configurations are listed below

A: Local distribution of a 10 MHz reference via coax to 12 local users

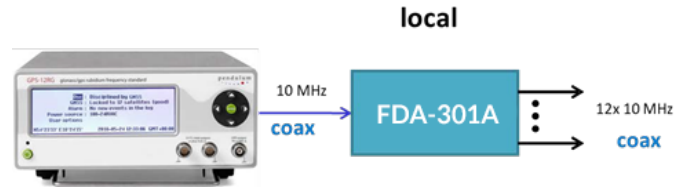

Each user receives 1x 10 MHz

3 coax (sine) output slots used in FDA-301A

B: Local distribution of a 10 MHz & 1-pps via coax to 8 local users

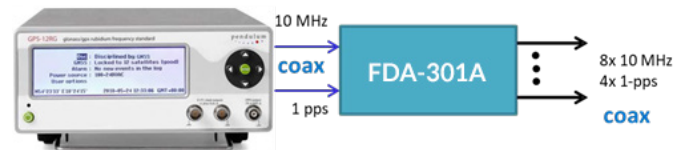

4 users receives 1x 10 MHz sine and 1x 1-pps pulse

4 users receive 1x 10 MHz sine only

2 coax (sine) output slots used in FDA-301A

1 coax (pulse) output slot used in FDA-301A

C: Remote distribution of 10 MHz, 1 site, 12 users

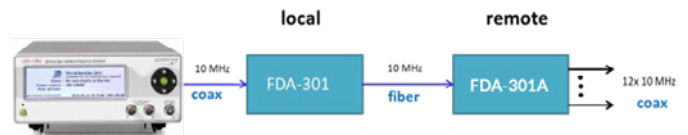

Each user receives 1x 10 MHz

1 fiber (sine) output slot used in 1 transmitter FDA-301A

3 coax (sine) output slots used in 1 receiver FDA-301A

D: Remote distribution of 10 MHz, 6 sites, 72 users

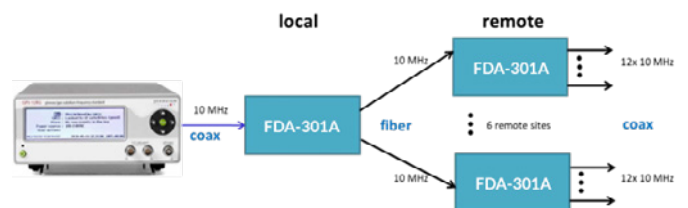

Each user receives 1x 10 MHz

1 fiber (sine) output slot used in 1 transmitter FDA-301A

3 coax (sine) output slots used in 6 receiver FDA-301A

E: Remote distribution of 10 MHz & 1-pps, 6 sites, 24 users

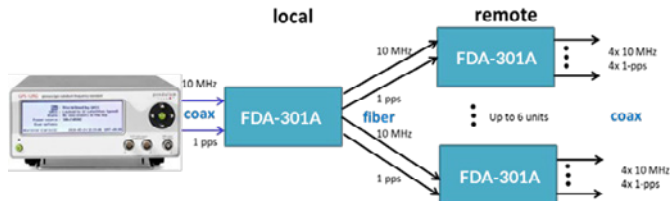

24 users receives 1x 10 MHz sine and 1x 1-pps pulse

2 fiber (1x sine + 1x pulse) output slots used in 1 transmitter FDA-301A
2 coax (1x sine + 1x pulse) output slots used in 6 receiver FDA-301A

F: Remote distribution of IRIG DCLS time code, 6 sites, 72 users

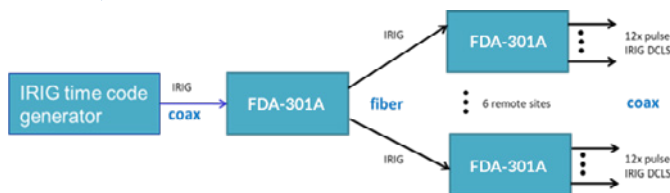

72 users receive 1x IRIG DCLS signal

1 fiber (pulse) output slot used in 1 transmitter FDA-301A
3 coax (pulse) output slots used in 6 receiver FDA-301A

Input and output connectors

Fiber Optic Ports

The fiber optic connectors are of ST type. The quality of the signal depends on the attenuation of the fiber optic cable and splices.

It is therefore essential to keep the attenuation low. Patch cables and splices should be kept as few as possible. Connectors shall be kept clean. Use a dry clean cotton cloth, or similar, for polishing. If alcohol or any other solution is used for cleaning, always polish with a dry cloth, to make sure that there is no residue left.

The AGC can control up to 8dB in link attenuation, which equals approximately 2km fiber. Two or more FDA-301A can be cascaded to extend link length.

BNC Ports

When using coaxial cables for distribution, there is always a potential risk for ground current loops, since the coax cable shield is connected to the instrument chassis ground at both ends of the cable. Ground current loops occur when the ground potential at the receiver is different from the ground potential at the transmitter. This occurs for example when the transmitting and receiving amplifiers are connected to different electrical switchboards. Ground current loops may add additional noise to the transmitted signal.

To prevent ground current loops, the BNC-ports can be isolated from the chassis ground, meaning just one grounding point of the transmission cable shield, instead of two

All BNC-ports are referenced to FDA-301A chassis at delivery.

There are insulation washers supplied with each FDA-301A, to insulate the BNC connector housing from the chassis.

All BNC ports can be individually configured to be insulated. Both the input ports and the output ports can be isolated

Configure as follows:

- Loosen nut at BNC – 14mm nut.



- Pull out the factory-fitted washers.



- Add one of the insulation washers delivered with the FDA-301A. The insulation washer must be mounted closest to the panel.



- Reassemble the washers and the nut as in the picture. Use gentle force while tightening the nut.



QUICK PERFORMANCE CHECK

This performance procedure is intended for incoming inspection to determine the acceptability of newly purchased instruments, or whenever a quick test is convenient.

Note: The procedure does not check every facet of the instrument. It is concerned primarily with those parts of the instrument which are essential for determining the function of the instrument.

Note: This Frequency Distribution Amplifier does not need to be sent away for calibration. The instrument contains no parts that are subject to ageing.

It is not necessary to remove the instrument cover to perform this procedure.

Recommended Test Equipment

- Oscilloscope with 50 ohm input
- Pendulum CNT-90 timer/counter/analyzer
- A low noise signal generator for sine waves 100 kHz to 60 MHz
- A pulse generator 1Hz to 20 MHz with fast rise time
- An optical power meter
- Short optical multimode fiber cable with ST-connectors, 2-5 meter

Power On test

- Connect the power plug to the rear panel of FDA-301A (No input signals connected)
- Verify that the AC power diode goes green, and the fan starts
- Verify that the input signals diodes goes red

Check of one Distribution unit in local mode (coax in/coax out)

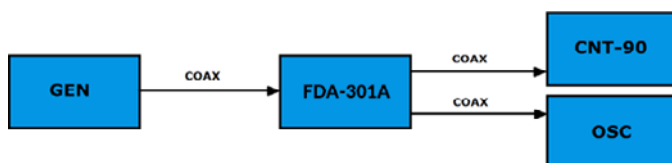

Sine input coax test

Connect output signal from Signal generator to sine input of the FDA-301A unit

- Set sine signal; 10MHz frequency and amplitude 1Vrms on generator

- Verify that sine signal diode goes green
- Set sine signal; 10MHz frequency and amplitude 0.2Vrms on generator
- Verify that sine signal diode goes green
- Set sine signal; 10MHz frequency and amplitude 2Vrms on generator
- Verify that sine signal diode goes green

Pulse input coax test

- Connect output signal from pulse generator to pulse input of the FDA-301A unit
- Set 1Hz frequency, duty cycle 50%, amplitude 5Vpp, Hi-level 5V, Low-level 0V on pulse generator
- Verify that pulse signal diode goes green
- Set 10MHz frequency, duty cycle 50%, amplitude 5Vpp, Hi-level 5V, Low-level 0V on pulse generator
- Verify that pulse signal diode goes green
- Set 20MHz frequency, duty cycle 50%, amplitude 5Vpp, Hi-level 5V, Low-level 0V on pulse generator
- Verify that pulse signal diode goes green

Sine output coax test

Connect output signal from signal generator to sine input of the FDA-301A unit

- Connect signal from the FDA-301A sine coax output module to input of the Oscilloscope (Use 50Ω termination)
- Set 10MHz frequency and amplitude 1Vrms sine signal on signal generator
- Verify using oscilloscope that the amplitude is 1Vrms $\pm 10\%$ ($V_{pp} = 2.8V \pm 10\%$), and that the waveform of the signal is not visibly distorted
- Set 10MHz frequency and amplitude 0.2Vrms sine signal on signal generator
- Verify using oscilloscope that the amplitude is 1Vrms $\pm 10\%$ ($V_{pp} = 2.8V \pm 10\%$), and that the waveform of the signal is not visibly distorted
- Set 10MHz frequency and amplitude 2Vrms sine signal on generator
- Verify using oscilloscope that the amplitude is 1Vrms $\pm 10\%$ ($V_{pp} = 2.8V \pm 10\%$), and that the waveform of the signal is not visibly distorted

Pulse output coax test

- Connect output signal from Pulse generator to the pulse input signal of the FDA-301A
- Connect signal from the FDA-301A pulse coax output module to input of the Oscilloscope (Use 50Ω termination)
- Connect signal from the FDA-301A pulse coax output module to input of CNT-90 (Set input impedance 50Ω and DC)
- Set 1Hz frequency, duty cycle 50%, amplitude 5Vpp, Hi-level 5V, Low-level 0V pulse signal on generator
- Verify using CNT-90 that the output frequency signal is 1Hz, the High level is $>2.4V$, and the Low level is $<0.4V$.
- Verify using the oscilloscope that the waveform of the signal is a pulse shape with overshoot/undershoot $<20\%$ of V_{pp}

- Set 10MHz frequency, duty cycle 50%, amplitude 5Vpp, Hi-level 5V, Low-level 0V pulse signal on generator
- Verify using CNT-90 that the output frequency signal is 10 MHz, the High level is >2.4V, and the Low level is <0.4V.
- Verify using the oscilloscope that the waveform of the signal is a pulse shape with overshoot/undershoot <20% of Vpp
- Set 20MHz frequency, duty cycle 50%, amplitude 5Vpp, Hi-level 5V, Low-level 0V pulse signal on generator
- Verify using CNT-90 that the output frequency signal is 20 MHz, the High level is >2.4V, and the Low level is <0.4V.
- Verify using the oscilloscope that the waveform of the signal is a pulse shape with overshoot/undershoot <20% of Vpp

Check of two FDA-301A Distribution Amplifiers with fiber in between (coax-fiber-coax)

Sine input coax test - transmitter unit

- Connect output signal from Signal generator to sine input of the FDA-301A unit
- Set sine signal; 10 MHz frequency and amplitude 1Vrms on Signal generator
- Verify that sine signal diode goes green
- Set sine signal; 10 MHz frequency and amplitude 0.2Vrms on Signal generator
- Verify that sine signal diode goes green
- Set sine signal; 10 MHz frequency and amplitude 2Vrms on Signal generator
- Verify that sine signal diode goes green

Pulse input coax test – transmitter unit

- Connect output signal from Pulse generator to pulse input of the FDA-301A unit
- Set 1 Hz frequency, duty cycle 50%, amplitude 5Vpp, Hi-level 5V, Low-level 0V on pulse generator
- Verify that pulse signal diode goes green
- Set 10 MHz frequency, duty cycle 50%, amplitude 5Vpp, Hi-level 5V, Low-level 0V on pulse generator
- Verify that pulse signal diode goes green
- Set 20 MHz frequency, duty cycle 50%, amplitude 5Vpp, Hi-level 5V, Low-level 0V on pulse generator
- Verify that pulse signal diode goes green

Sine output fiber test - transmitter unit

- Connect the output of the Signal generator to the Sine input of the transmitter FDA-301A unit
- Connect the signal from the Sine Fiber output module of the FDA-301A transmitter to the input of the optical power meter
- Set 10 MHz frequency and amplitude 1 Vrms sine on the Signal generator
- Verify that the optical power level of the output is between -15 and -18 dBm

Pulse output fiber test - transmitter unit

- Connect the output of the Pulse generator to the Pulse input of the transmitter FDA-301A unit
- Connect the signal from the Pulse Fiber output module of the FDA-301A transmitter to the input of the optical power meter
- Set 1Hz frequency, duty cycle 50%, amplitude 5Vpp, Hi-level 5V, Low-level 0V pulse signal on generator
- Verify that the optical power level of the output is between -15 and -18 dBm
- Set 10 MHz frequency, duty cycle 50%, amplitude 5Vpp, Hi-level 5V, Low-level 0V pulse signal on generator
- Verify that the optical power level of the output is between -15 and -18 dBm

Sine input fiber test - receiver unit

- Connect the output of the Signal generator to the Sine input of the transmitter FDA-301A unit
- Connect the signal from the Sine Fiber output module of the FDA-301A transmitter to the sine fiber input of the FDA-301A receiver, using a short optical cable (2-5 meters).
- Set 10MHz frequency and amplitude 1Vrms sine on the Signal generator
- Verify that the sine signal diode on the FDA-301A receiver unit goes green

Pulse input fiber test - receiver unit

- Connect the output of the Pulse generator to the Pulse input of the transmitter FDA-301A unit
- Connect the signal from the Pulse Fiber output module of the FDA-301A transmitter to the pulse fiber input of the FDA-301A receiver, using a short optical cable (2-5 meters).
- Set 1Hz frequency, duty cycle 50%, amplitude 5Vpp, Hi-level 5V, Low-level 0V on pulse generator
- Verify that pulse signal diode goes green
- Set 10MHz frequency, duty cycle 50%, amplitude 5Vpp, Hi-level 5V, Low-level 0V on pulse generator
- Verify that pulse signal diode goes green

Sine output coax test - receiver unit

- Connect the output of the Signal generator to the Sine input of the transmitter FDA-301A unit
- Connect the signal from the Sine Fiber output module of the FDA-301A transmitter to the sine fiber input of the FDA-301A receiver, using a short optical cable (2-5 meters).
- Connect signal from the sine coax output module of the FDA-301A receiver to the input of the
- Oscilloscope (Use 50Ω termination)
- Set 10MHz frequency and amplitude 1Vrms sine signal on signal generator
- Verify using oscilloscope that the amplitude is 1Vrms ±10% (Vpp = 2.8V ±10%), and that the waveform of the signal is not visibly distorted

Pulse output coax test - receiver unit

- Connect the Pulse generator output to the Pulse input of the transmitter FDA-301A unit
- Connect the signal from the Sine Fiber output module of the FDA-301A transmitter to the sine fiber input of the FDA-301A receiver, using a short optical cable (2-5 meters).
- Connect the signal from the pulse coax output module of the FDA-301A receiver to the input of the Oscilloscope (Use 50Ω termination)
- Connect the signal from the pulse coax output module of the FDA-301A receiver to the input of CNT-90 (Set input impedance 50Ω and DC)
- Set 1Hz frequency, duty cycle 50%, amplitude 5Vpp, Hi-level 5V, Low-level 0V pulse signal on the Pulse generator
- Verify using CNT-90 that the output frequency signal is 1Hz, the High level is >2.4V, and the Low level is <0.4V.
- Verify using the oscilloscope that the waveform of the signal is a pulse shape with overshoot/undershoot <20% of Vpp
- Set 10MHz frequency, duty cycle 50%, amplitude 5Vpp, Hi-level 5V, Low-level 0V pulse signal on the Pulse generator
- Verify using CNT-90 that the output frequency signal is 10 MHz, the High level is >2.4V, and the Low level is <0.4V.
- Verify using the oscilloscope that the waveform of the signal is a pulse shape with overshoot/undershoot <20% of Vpp

PREVENTIVE MAINTENANCE

No calibration needed

No traditional yearly calibration is needed for the FDA-301A. There are no components inside affecting the specifications that are subject to ageing. However, we recommend a bi-yearly performance check (Chapter 5) to verify that the unit is free from HW faults.

Fan Replacement

The FDA-301A contains a fan with an expected life time of 5 years with continuous 24h/day operation.

We recommend replacing the fan every 3 years to maintain continuous high reliability. For part-time applications and low ambient temperatures, an extended service interval is acceptable.

Fan replacement requires no special tools (screwdrivers only). The part number of the replacement fan is 4031 105 02850.

Contact your Pendulum distributor for fan replacement.

TECHNICAL SPECIFICATIONS

Inputs

Fiber optic inputs Sine, Pulse

Fiber optical connector: ST

Wavelength: 820nm

Fiber type: Multimode fiber, 62.5/125 μ m or 50/125 μ m

Frequency for sine input: 10 MHz (default); for other frequencies, 0.1 to 60 MHz, contact factory

Connection fiber from an FDA-301A output to another FDA-301A input:

Max. optical attenuation: 6dB (including fiber and all connectors and splices)

Max. distance: 2km

Coax Input Sine

Connector: BNC female

Frequency: 10 MHz (default);

for other frequencies, 0.1 to 60 MHz, contact factory

Impedance: 50 Ohm nominal

Amplitude range: 0.2 Vrms to 2 Vrms (nom.)

Max. Voltage without damage: 7Vrms

Coax Input Pulse

Connector: BNC female

Frequency range: 1 Hz to 20 MHz

Min. Pulse width: \leq 20ns

Max. Pulse width: \geq (signal period - 20ns Impedance: 50 Ohm nominal)

Amplitude range: 0V to +5V (nom.)

Low level <0.8V; high level > 2V

Max. Voltage without damage: 15Vp-p
(-5V to +10V)

Time of Day (ToD) Input

Connector: Mini Din 6 pins Female; RS232C electrical levels accepted from -10V to +10V

Maximum repetition rate: 500 kHz

Outputs

Fiber optic outputs Sine, Pulse

Connectors: ST

Wavelength: 820nm

Fiber type: Multimode fiber, 62.5/125 μ m or 50/125 μ m

Max. distance: 2km

Pulse jitter (rms): < 10 ps + optical jitter).

Optical jitter is due to optical attenuation and dispersion and depends on quality and length of fiber used. Optical jitter is 0

ps for 1m and typically <100ps for 1km

Coax Output Sine

Connectors: BNC female

Impedance: 50 Ohm nominal

Output voltage: 1Vrms (sine) \pm 10% in 50 ohm

Coax Output Pulse

Connectors: BNC female

Impedance: 50 Ohm nominal

Output voltage: TTL-levels in 50 Ohm;

low level \leq 0.4 V; high level \geq 2.4 V

Time of Day (ToD) Output

Connector: Mini Din 6 pins Female:

Output voltage levels: Low level is -5V nom.;

High level is +5V nom.

Max cable length: 100 m

Output modules

Coax Sine: 4x 10 MHz

Fiber Sine: 6x 10 MHz

Coax Pulse: 4x pulse out

Fiber Pulse: 6x pulse out

T.o.D: 4x T.o.D. electrical

Power Supply

AC power

Input voltage range: 90 - 264V_{AC}, 47 - 63Hz

Power consumption: <40 W

DC power - Option

Input voltage range: 24 V \pm 10%

Power consumption: <40 W

Dimensions and Weight

Width: ½*19 inch (210 mm)

Height: 2U (90 mm)

Depth: 395 mm

Weight: approx. 3 kg (approx. 6 lb)

Environmental conditions

Class: MIL-PRF-28800F, Class 3

Operating temperature: 0 to 50°C

Storage temperature: -40 to +70°C

Vibration: Random and sinusoidal according to MIL-PRF-28800F, Class 3

Shock: Half-sine 30G per MIL-PRF-28800F; Bench handling

Transit drop test: Heavy-duty transport case and soft carrying case tested according to MIL-PRF-28800F

Safety: EN 61010-1:2011, pollution degree 2, meas cat I, CE, indoor use only

EMC: EN 61326 :2013-6, increased test levels according to EN 61000-6-2:2008, Group 1, class B, CE

Ordering Information

Basic Model

FDA-301A/11000: Frequency Distribution Amplifier, 10 MHz sine coax and fiber inputs, no output modules, AC power.

At least one output module must be ordered simultaneously.

Included with Instrument:

- 2 year product warranty¹
- Line cord (dependent on destination country)
- Link to User documentation (PDF)
- Certificate of Calibration
- Important information document

¹ Warranty period may be extended to 3 years, at no cost, by registering the product

Input Frequency Options

(10 MHz sine, coax and fiber, inputs are standard)

Option 41: Pulse coax and fiber inputs

Option 42: 2x ToD electrical (mini DIN 6-pin F)

The Input options are factory installed only.

Output Frequency Options

(1, 2 or 3 modules can be installed)

Option 44C: 4x 10 MHz coax

Option 44F: 6x 10 MHz fiber

Option 45C: 4x pulse coax

Option 45F: 6x pulse fiber

Option 46E: 4x ToD electrical

The Output options can be field installed by the user

Power Supply Option

Option 49: External DC power supply for 24V DC

The Power supply option is factory installed only

Optional Accessories

Option 22/90: Rack-mount kit for one FDA-301A unit

Option 22/05: Rack-mount kit for two FDA-301A units

Option 27: Soft carrying case

Option 27H: Heavy-duty hard transport case

Option 95/05: Extended warranty to 5 years

OM-301: Printed User's Manual

Ordering numbers:

FDA-301A/XYZZZ

X = Input options

Y = Power options

Z = Output options (3 slots)

X=1: 10 MHz only

X=2: 10 MHz + pulse

X=3: 10 MHz + ToD

X=4: Not used

X=5: 10 MHz + pulse + ToD

Y=1: AC power

Y=2: AC + DC power

Z=0: module not installed

Z=1: 4x 10 MHz coax

Z=2: 6x 10 MHz fiber

Z=3: 4x pulse coax

Z=4: 6x pulse fiber

Z=5: 4x ToD electrical

Example: FDA-301A/11021 = FDA-301A with 10 MHz inputs only (X), no DC option (Y) plus one empty output slot, one 6x 10 MHz fiber output, and one 4x 10 MHz coax output (ZZZ).

<https://mod-e.ru/>

© Pendulum Instruments 2023
18.04.2023. FDA-301A. User Manual
Specifications subject to change
or improvements without notice.