

pendulum

DUAL CHANNEL LINEAR AMPLIFIER WITH PHASE INVERTER Model A400DI



HIGH VOLTAGE

$\pm 200V$
150mA

FIXED GAIN

20x

BROADBAND

DC to ca 500 kHz
FULL SCALE

LOW OUTPUT IMPEDANCE

$< 0.1 \Omega$

HIGH SLEW RATE

400 V/ μ s

GENERAL DESCRIPTION

The **A400DI** is a general purpose linear amplifier designed for laboratory use. It is based on a fast high-voltage operational amplifier with a feedback network chosen to give a voltage amplification of 20 times. Any function or arbitrary waveform generator with low output impedance and output voltage up to ± 10 V can be used as an input device. The instrument contains two identical amplifiers that share a single power supply and a common ground reference. It also includes a low voltage phase inverter that facilitates driving the two high voltage outputs in counter-phase.

The amplifier outputs high voltage signals at high frequency. It is, thus, imperative for the safe operation that the user understands the possibilities and limitations of the instrument. Isolated BNC output connector is used to comply with safety requirements.

INPUT AMPLITUDE

The amplitude of the input signal should normally be kept within ± 10 V. The input protection network limits the signal amplitude delivered to the power amplifier to a safe value. It also effectively cuts accidental spikes and overshoots. However, large and/or prolonged overvoltage at the input may blow the microfuse in the input protection circuit. (A spare fuse is provided inside the instrument. If possible, contact service@pendulum-instruments.com for advice before opening the instrument case.)

Keep input signals within ± 10 V range. Never connect the high voltage output to the input of the instrument!

TROUBLESHOOTING

Problem	Condition	Solution
No output	Power switch does not lit	Check the mains fuse located on the back
No output or very small, distorted signal	Power switch OK	Check the input microfuse located <u>inside</u> the device.
Constant high voltage output	Without any input signal	Amplifier failure. Contact service@pendulum.se

You should suspect a blown input microfuse if the output is about zero or the amplifier is producing a very low voltage, distorted copy of the input signal (due to the capacitive coupling through the blown fuse).

PHASE INVERTER

The **A400DI** contains a phase inverter which shares the input with amplifier “1” (see drawing). It is intended to allow a bridge connection of the amplifiers and the load to achieve double amplitude of the output signal. In such a case, the output of the phase inverter should be connected to the input of the second amplifier, an external signal supplied to the input of the first amplifier and the load connected between the outputs of both amplifiers as in the example below:

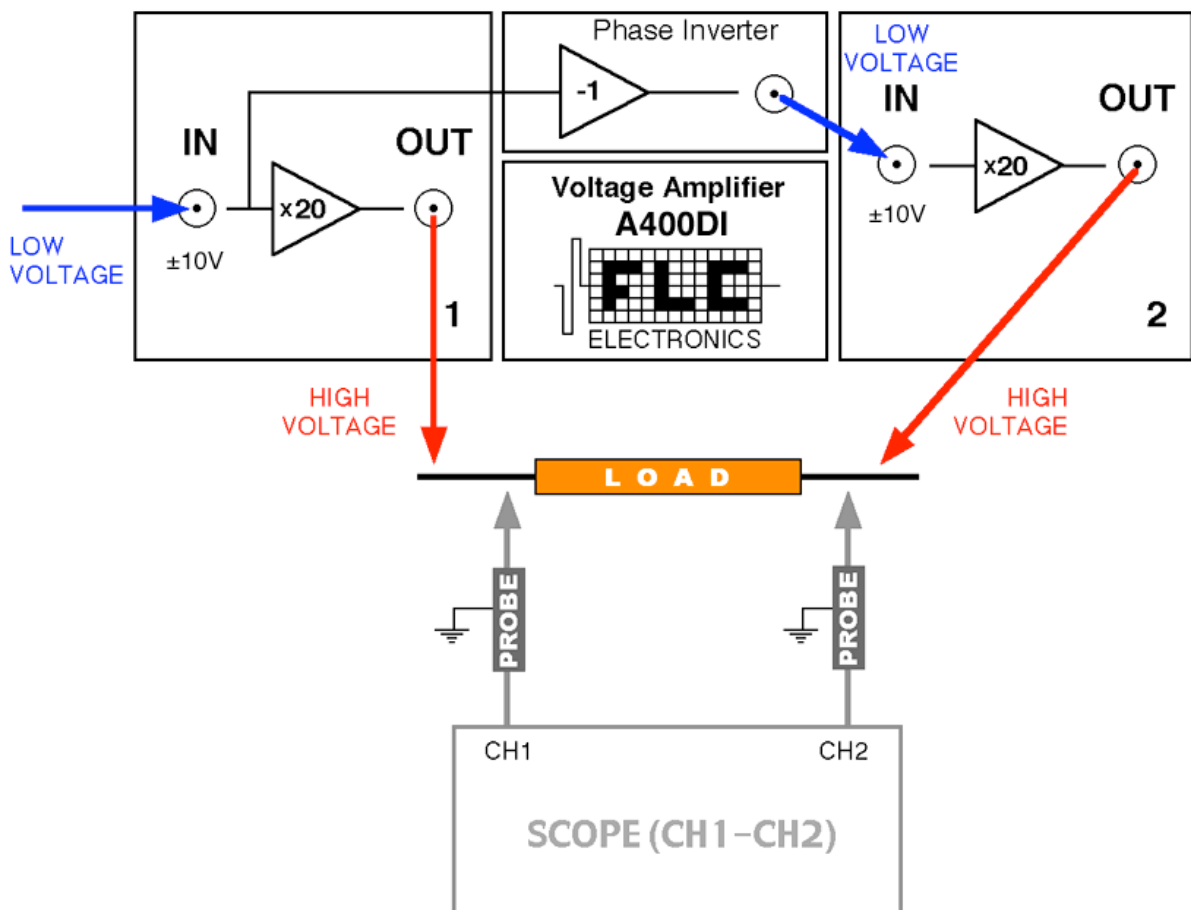

Observe, that both sides of the connected load are actively driven and must be isolated from the ground. The voltage over the load is in this case $U_1 - U_2 = U_1 - (-U_1) = 2U_1$ since $U_2 = -U_1$.

It is, of course, possible to supply separate signals to the low voltage inputs of both amplifiers and still use the differential connection of the load, as in the drawing. The amplifiers can also be used as two independent units sharing the common ground reference.

PLEASE NOTE:

In the differential configuration - isolate the load from ground and use two separate oscilloscope probes to monitor the voltage over the load.

LOAD

The amplifier is intended to drive resistive and/or small capacitive loads. The maximum capacitive load depends on the slew rate of the amplifier. This is normally set at the factory to 300 V/ μ s which yields the load limit of 400 pF. This limit includes the capacitance of the connection cable (ca 100 pF/m for a standard coaxial cable). Increasing the capacitive load causes overshoot to appear. If a larger capacitive load is required, and the overshoot is not acceptable, then the slew should be reduced accordingly. Such an adjustment may be performed by qualified personnel and the factory should be contacted for advice (preferably by email service@pendulum-instruments.com). Inside the cabinet exist hazardous voltage levels and the amplifier circuit is sensitive to static discharge.

Pendulum Instruments recommends to monitor the output signal of the amplifier with an oscilloscope. It is then important to use a low capacitive probe with a division factor of at least 1/10.

Overloading the output may cause an overshoot which might be dangerous for connected devices.

The amplifier output is equipped with fast-recovery diodes for protection against high energy flyback and can be used to drive small (mH) inductances in series with resistance.

The amplifier cannot be used to drive a purely inductive load.

The continuous output current limit is 150 mA and the output power limit is 30 W. The output is equipped with a current limiting circuit that withstands accidental short-circuits. Prolonged short-circuiting may result in overheating the amplifier.

The amplifier may be overheated when the output is short-circuited for a long time.

FREQUENCY RESPONSE

The frequency response to 100% of the input amplitude and with 300 pF load is shown in the following diagram:

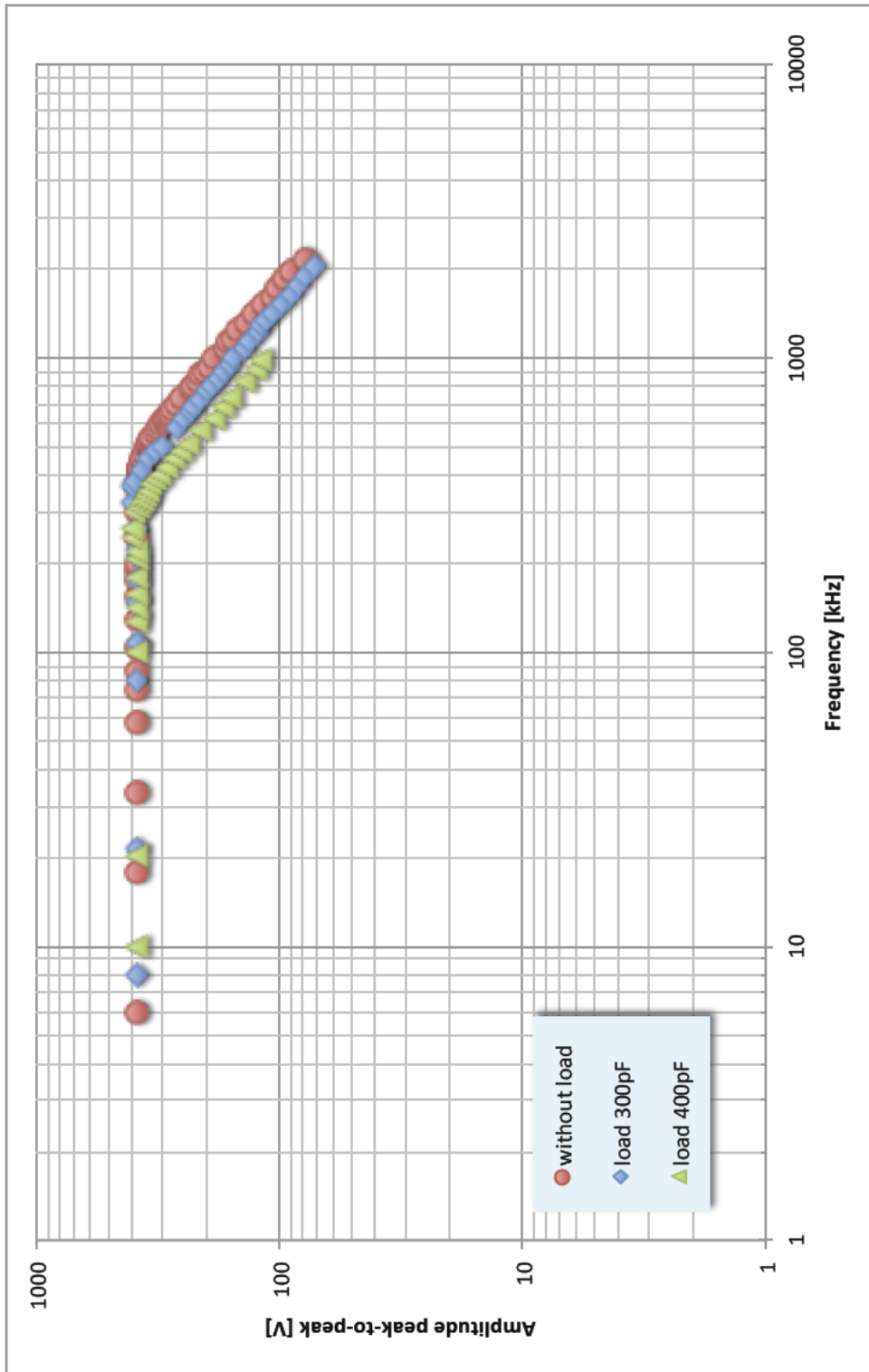

SUMMARY OF TECHNICAL DATA

Bandwidth:		DC to about 500 kHz at 400 V _{pp}
Amplification:		20 times
Load:	type	resistive capacitive
Impedance:	input	1 M Ω 30 pF, custom values possible
	output	<0.1 Ω in the linear mode
Voltage:	input	nominal ± 10 V
Current:	output	maximum 150 mA each channel
Slew Rate:	output	ca 400 V/ μ s (different adjustments available on request)
Input protection fuse		15 mA (Littelfuse, part number 272.015) one spare fuse provided inside the instrument, additional fuses available from Littelfuse resellers or from Pendulum Instruments .
Operating Ambient Temperature:		0°C to 30°C
Storage Temperature:		0°C to 60°C
Relative Humidity:		up to 90% (operation) 30% to 50% (storage)
Power Requirements:		100/110 V or 220/230 V, 50/60 Hz
Fuse:		100/110 V: 3.15 A (slow), 220/230 V: 2 A (slow)
Dimensions (H/W/L):		112 x 255 x 316 (mm)
Weight:		4 kg
Country of Origin:		Poland

Note: Specifications apply to instruments operating at 23°C \pm 5°C ambient temperature after 15 min. warm-up time. Due to ongoing product development, specifications are subject to change without notice.

WARNING It is not allowed to connect the 100...230V AC line power input of the amplifier to DC-AC converters or solid state AC generators with non-sinusoidal output.

Data sheet revision date: Friday, 15 February 2019

I M P O R T A N T



Inside the amplifier case exist dangerous voltage levels.



The instrument cannot be powered from a DC-AC converter nor from a solid-state AC generator with non-sinusoidal output.



Loads sensitive to voltage transients should be disconnected from the amplifier during power-up and power-down.



Never connect the output to the input of the amplifier!



The amplifier may be overheated if the output is short-circuited for a long time.



The maximum allowable capacitive load depend on the internal setting of the slew rate. Overloading the output is likely to cause overshoot. Slow down the amplifier to accommodate a larger load.



It is recommended to monitor the output signal of the amplifier on the oscilloscope.

WARRANTY

The Warranty Statement is part of the folder *Important Information* that is included with the shipment.

DECLARATION OF CONFORMITY

The complete text with formal statements concerning product identification, manufacturer and standards used for type testing is available on request.

<https://mod-e.ru/>

© Pendulum Instruments 2020
September 2020
Specifications subject to change
or improvements without notice.