

R&S® SMW200A

VECTOR SIGNAL GENERATOR

The fine art of signal generation



Product Brochure
Version 11.00

ROHDE & SCHWARZ

Make ideas real



AT A GLANCE

The R&S®SMW200A is the vector signal generator for the most demanding applications. Its flexibility, performance and intuitive operation make it a perfect tool for generating complex, high-quality digitally modulated signals.

The R&S®SMW200A is the ideal generator for digitally modulated signals required for the development of new wideband communications systems, the verification of 4G and 5G base stations and in the aerospace and defense sector.

The I/Q modulation bandwidth of up to 2 GHz with internal baseband satisfies fourth and fifth generation standards (e.g. 5G, LTE-Advanced and IEEE 802.11ac/ad), and the R&S®SMW200A is designed to meet future requirements. Its scalable modular architecture allows users to optimize the generator to their applications and to upgrade it as required.

A second RF path can be added, as well as a maximum of two baseband and four fading simulator modules, without compromising signal quality. As a result, the R&S®SMW200A can create signal scenarios that previously required multiple instruments or could not be implemented at all. From up to 8x8 MIMO and LTE-Advanced carrier aggregation including fading to multistandard radio – never before has an instrument offered such outstanding signal generation.

If more than two RF paths are required, additional R&S®SGMA signal generator modules can be connected. The intuitive touchscreen based operating concept provides the user with an overview of measurements, no matter how complex, and quickly delivers the desired results.

KEY FACTS

- ▶ Frequency range from 100 kHz to 3/6/7.5/12.75/20/31.8/40/44/56/67 GHz (overrange: 72 GHz)
- ▶ Extended frequency range from 70 GHz to 170 GHz with R&S®FE110ST, R&S®FE170ST external frontends
- ▶ Optional second RF path with 100 kHz up to 3/6/7.5/12.75/20/31.8/44 GHz
- ▶ Up to 2 GHz RF modulation bandwidth with internal baseband
- ▶ Excellent signal quality for high accuracy in spectral and modulation measurements
- ▶ Optional integrated fading simulator with up to 800 MHz bandwidth
- ▶ Supports all key MIMO modes including 3x3, 4x4, 8x4, 4x8, 8x8 and 4x2x2
- ▶ Intuitive operation via touchscreen with block diagram as key element

BENEFITS

- For all your needs
▶ page 4
- Simplify your setup
▶ page 6
- Bring reality to your lab
▶ page 10
- Make your device even better
▶ page 12
- Speed up your development
▶ page 16
- Grows with your needs
▶ page 18



FOR ALL YOUR NEEDS

Advanced RF test and measuring equipment must, above all, be flexible. Performance and functionality requirements vary depending on test setup and application. The R&S®SMW200A is unrivaled in mastering this challenge and sets new standards for signal generators. The instrument always generates the appropriate test signals – in development and verification, and for any type of DUT (components, modules, complete base stations).

Versatile configuration

Thanks to its modular design, the R&S®SMW200A can be equipped with the exact options required for a specific application. Any configuration is possible – from a classic single-path vector signal generator to a multichannel MIMO receiver tester.

The generator can be equipped with a maximum of two internal baseband modules and four fading simulator modules. A second RF path can also be installed. This concept yields two full-featured vector signal generators in a single unit, so that even complex signal scenarios (e.g. wanted signal + interferer, dual cell, TX/RX diversity) can be created easily.

Ideal for MIMO, MSR and LTE-Advanced applications

And that is only the beginning. The capabilities of the R&S®SMW200A surpass those of two conventional generators combined. When the instrument is fully equipped, the baseband section provides up to eight independent signal sources and up to 64 logical faders. This makes the R&S®SMW200A ideal for MIMO and other complex applications encountered in LTE-Advanced (carrier aggregation), HSPA (dual carrier), multistandard radio, etc.

Modular architecture for optimal adaptation to the application at hand

Almost all options of the R&S®SMW200A can be retro-fitted, most of them simply via keycode. Starting from the basic configuration as a classic single-path vector signal generator, the R&S®SMW200A can be customized as required for any application. Users only have to purchase what they currently need and are free to decide on upgrades depending on their future requirements.



R&S®SMW200A vector signal generator with an R&S®FE170ST external frontend

Basic R&S®SMW200A architecture

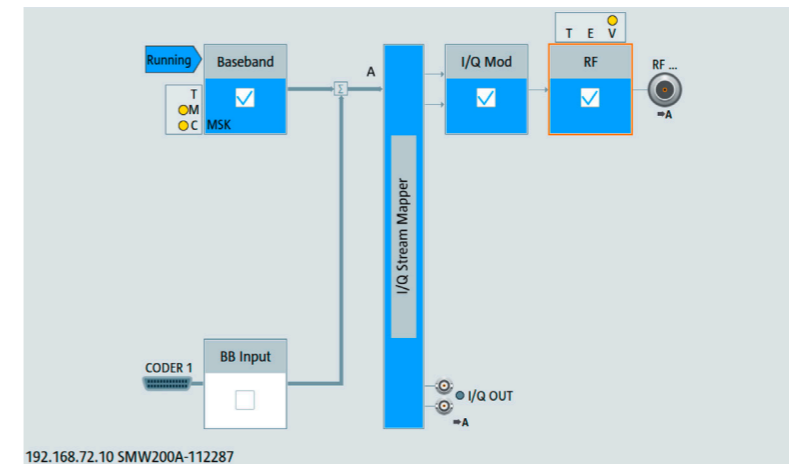
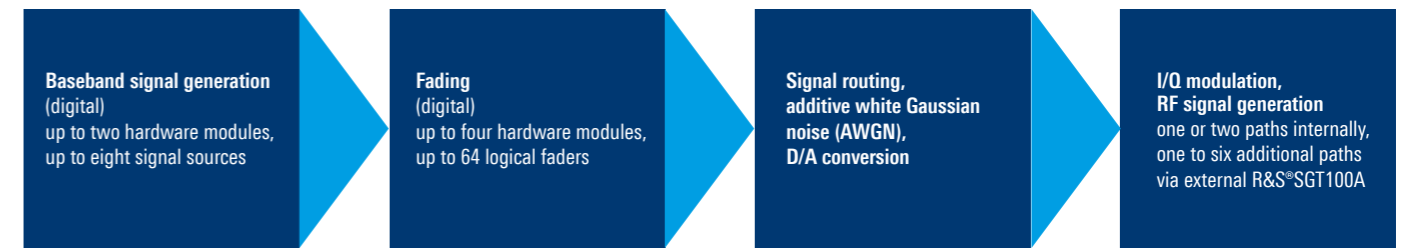

Configuration example 1:

A single-path R&S®SMW200A with internal baseband can be used for measurements on components or for fundamental receiver testing

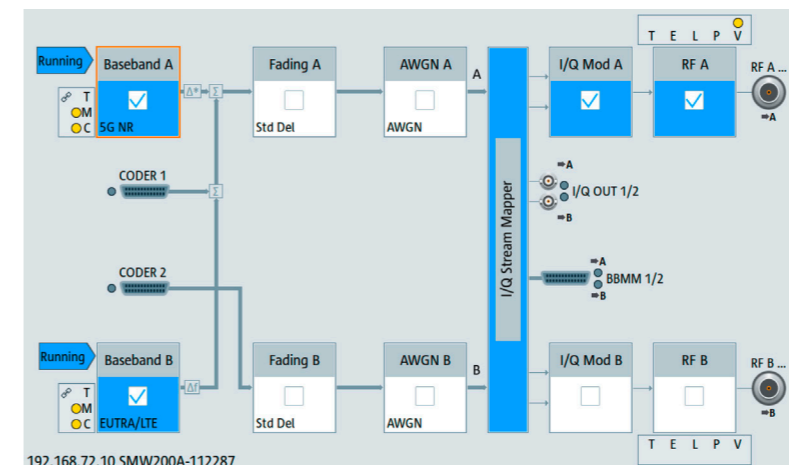

Configuration example 2:

A two-path R&S®SMW200A is ideal for receiver and performance tests on base stations. One generator can generate the wanted signal plus interferer (in this example a wanted 5G NR signal and an LTE interferer).

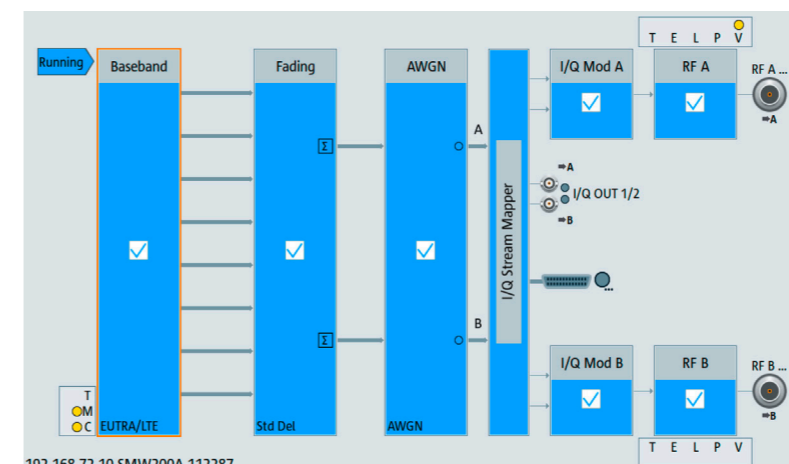

Configuration example 3:

A fully equipped R&S®SMW200A with MIMO option covers all key MIMO scenarios, such as 8x2 shown here. In this case, the baseband section provides eight signal sources and 32 logical faders, i.e. MIMO channels.

SIMPLIFY YOUR SETUP

Wideband baseband and vector signal generator in one box

A vector signal generator needs a powerful baseband section to meet the requirements of advanced communications systems. The R&S®SMW200A sets standards in this field, too. It can be equipped with a baseband section that provides up to 2 GHz internal RF modulation bandwidth. This option makes the R&S®SMW200A the first vector signal generator to offer a fully calibrated wideband solution up to 67 GHz in a single instrument.

One or two baseband generators can be installed in a single instrument, which makes it possible to generate two independent wideband signals up to 44 GHz with any type of modulation using just one instrument.

Each of the two available baseband modules contains a real-time coder and an arbitrary waveform generator with max. 2 Gsample memory depth. The bandwidth of up to 2 GHz covers modern digital standards, such as 5G NR, LTE and WLAN IEEE802.11be, as well as wideband multicarrier or multistandard radio signals.

Easy generation of complex signals

The baseband signals can be digitally added, provided with a frequency offset of max. ± 1 GHz and varied in power and phase relative to each other. This makes it incredibly simple to generate multicarrier scenarios and combinations of different digital standards with the R&S®SMW200A.

Two-path R&S®SMW200A

In a two-path R&S®SMW200A, baseband signals can be digitally added and provided with baseband frequency offset, making it possible to easily generate multicarrier scenarios or wanted signal plus interferer scenarios.

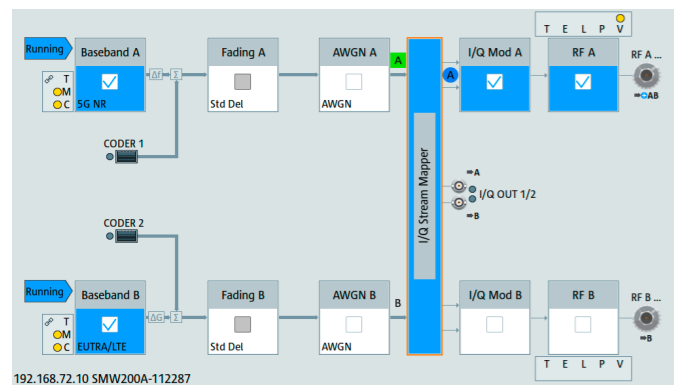

A single two-path R&S®SMW200A is all that is needed to create the wanted signal plus interferer scenarios often required in receiver testing. Depending on the scenario's overall bandwidth and the desired level difference between wanted signal and interferer, the signals can in many cases be output by using only one RF path. The second RF path is available for other tasks, e.g. generation of an additional CW interferer.

Advanced multichannel signal generation

The R&S®SMW200A generator's advanced baseband architecture enables it to simulate even complex scenarios. Up to eight internal baseband sources make it easy to generate multiple signals required, for example, for LTE carrier aggregation, multicell/multi-user simulation, interference testing and multistandard radio (MSR) tests. Optional fading and noise simulation for each of the eight individual channels is also possible.

Flexible routing capabilities and internal real-time addition of the baseband signals allow a parallelized testing approach. All signals are generated with their own periodicity. This allows the simultaneous generation of multiple carriers with nontruncated data sequences and enables a DUT to perform demodulation tests for each of the signals at the same time. As a result, the overall test time is reduced and only a minimum of hardware investment is needed.

Covering modern technologies: 5G and IEEE 802.11ad

The R&S®SMW200A is the ideal tool for engineers who develop components, devices or infrastructure for the next generation of mobile communications. 5G New Radio signals are directly created on the instrument, helping users to efficiently master their design challenges. Typical test scenarios such as coexistence tests with LTE and wideband 5G signal generation in the microwave range are covered by a single instrument. WLAN IEEE 802.11ad

signals with a symbol rate of 1.76 Gsample/s in single carrier mode are supported as well. Due to its intelligent internal modulation frequency response compensation, the R&S®SMW200A also excels in I/Q flatness and modulation quality for all wideband signals.

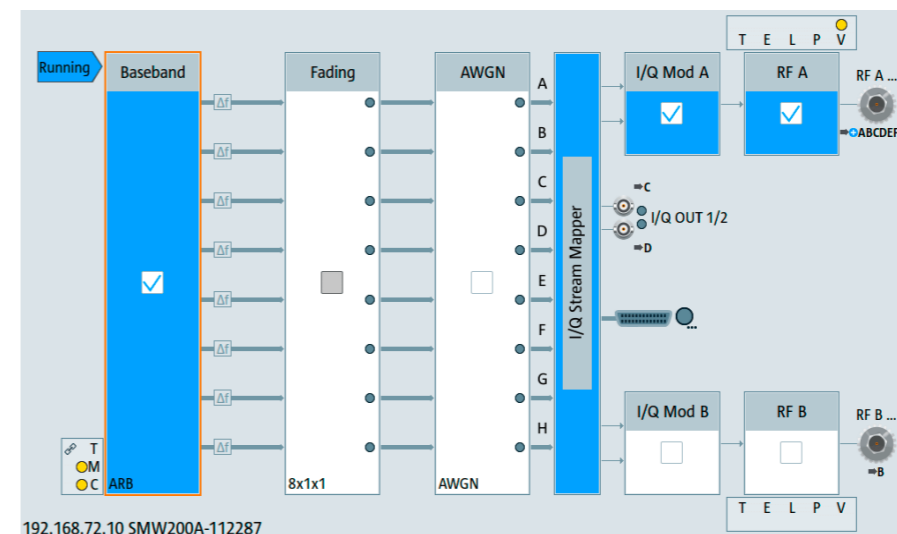

The R&S®SMW200A is the ideal generator for multistandard radio and interference tests. Here, it is generating eight different frequency-spaced signals that are added up in real time for receiver testing.

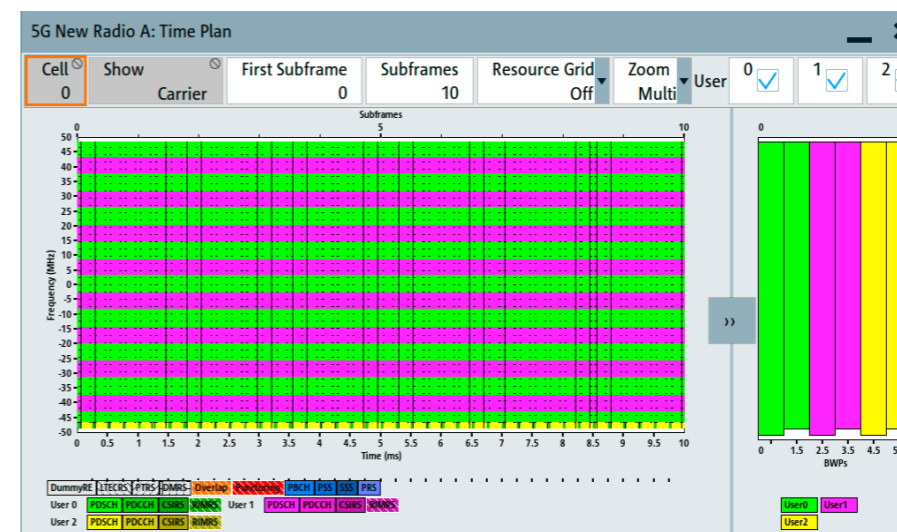

Time plan display in the 5G NR option of the R&S®SMW200A

Support of all important digital standards

The R&S®SMW200A uses software options to generate signals for all important digital standards, particularly 5G NR, LTE/LTE-Advanced (up to Release 15), 3GPP FDD/HSPA/HSPA+, GSM/EDGE/EDGE Evolution and WLAN IEEE 802.11a/b/g/n/j/p/ac/ax/ad/be. The entire physical layer is simulated, as well as channel coding for the majority of standards. This makes the instrument perfect for standard-compliant receiver measurements, e.g. tests on base stations in line with 3GPP TS38.141 (for 5G NR) or 3GPP TS36.141 (for LTE/LTE-Advanced).

In contrast to many other solutions on the market, the signals for the digital standards can be configured and generated directly on the R&S®SMW200A. Because the software options integrate seamlessly into the instrument's firmware, there is no need for additional PC software. This simplifies operation and also saves valuable testing time, since no time-consuming waveform transfer from the external PC software to the signal generator's output memory has to be performed.

Thanks to its outstanding performance, the R&S®SMW200A responds virtually without delay to new settings, even when they require comprehensive signal calculations. Test scenarios can therefore be adapted to new requirements quickly and easily. Parameters can be varied with immediate effect for optimization or troubleshooting, without causing unproductive interruptions or waiting time.

Users benefit from numerous help functions. Predefined settings can be used to configure standard-compliant signals, e.g. test models defined in the standard, at the press of a button. Visual aids such as the time plan in the LTE option provide a graphical overview of the signal structure. They help users keep track of even complex signal scenarios and quickly set the desired parameters. The test case wizards for complex digital standards such as 5G NR, LTE and 3GPP FDD (UMTS) are powerful tools that simplify the user's task. It only takes a few steps to configure the R&S®SMW200A for base station tests in line with 3GPP TS38.141, 3GPP TS36.141 or 3GPP TS25.141.

Generating signals for radar module and receiver tests

Together with the R&S®Pulse Sequencer Software, the R&S®SMW200A generates simple pulses, pulse trains as well as complex multi-emitter and multichannel radar scenarios. For each individual pulse, the pulse timing and the intrapulse modulation such as AM/FM, wideband chirp, Barker and polyphase can be configured flexibly. Control elements such as nested loops, overlays and subsequences allow dynamic sequencing applications. Deterministic or random interpulse modulation profiles enable the user to configure time-varying pulse train characteristics with minimum effort.

Antenna diagrams and antenna scans can be added to the defined pulse sequences to simulate realistic radar emitters. For scenario simulation, multiple emitters and a receiver can be placed on a 2D map, including attitude and height information. Using an additionally configured receiver antenna diagram and antenna scan, the R&S®SMW200A creates real-world signals as they occur

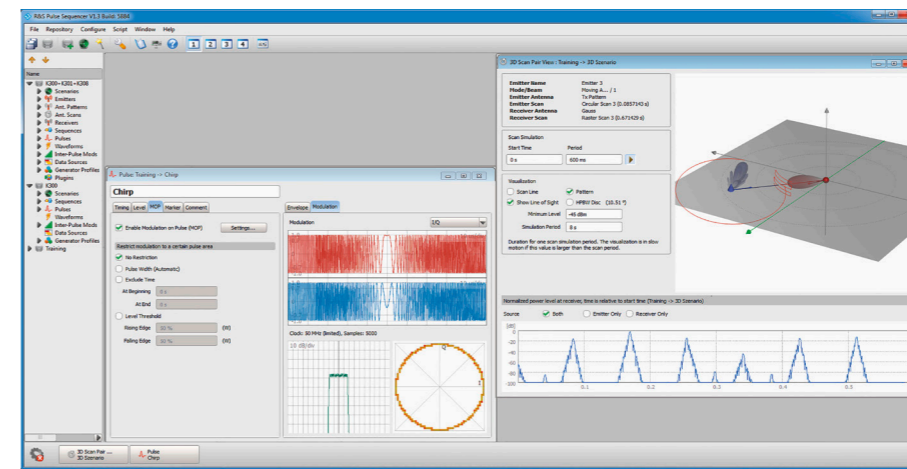

R&S®Pulse Sequencer Software for creating radar signals and scenarios with the R&S®SMW200A

at the RF output of a receiver antenna. This allows inexpensive conducted receiver tests in the lab instead of costly over-the-air field tests. The emulated receiver can even be configured to carry multiple antennas, each with individual antenna pattern, position and pointing direction. This turns the R&S®SMW200A into a powerful platform for testing radar modules as well as multichannel receivers in direction finding applications.

Furthermore, the R&S®SMW200A together with the R&S®Pulse Sequencer Software creates radar signals as specified by FCC, ETSI or the TELEC T403 standard for dynamic frequency selection (DFS) tests. This makes the R&S®SMW200A the ideal solution for testing WLAN devices for correct behavior in the presence of a radar signal in the same frequency band.

Efficient testing of amplifiers with envelope tracking

The objective of envelope tracking (ET) is to reduce power consumption and the amplifier's overall energy consumption. Instead of receiving a constant supply voltage, the amplifier is fed a voltage from a DC modulator. This voltage tracks the envelope of the RF signal. Extremely precise synchronization is crucial since even deviations in the nanosecond range would cause significant modulation errors, e.g. error vector magnitude (EVM).

The R&S®SMW200A offers options that allow users to very easily generate the right envelope signal for an RF signal in real time and output it at the analog I/Q output. Since both signals come from the same instrument, users do not need to worry about synchronization. The delay between the RF signal and the envelope signal relative to each other can be set in real time with a 1 ps resolution in order to compensate for different delays in the test setup. The digital predistortion option enables AM/AM and AM/φM predistortion of the signals in real time. This flexibility and the outstanding signal performance of the R&S®SMW200A make it the perfect signal source for precise and efficient ET measurements.

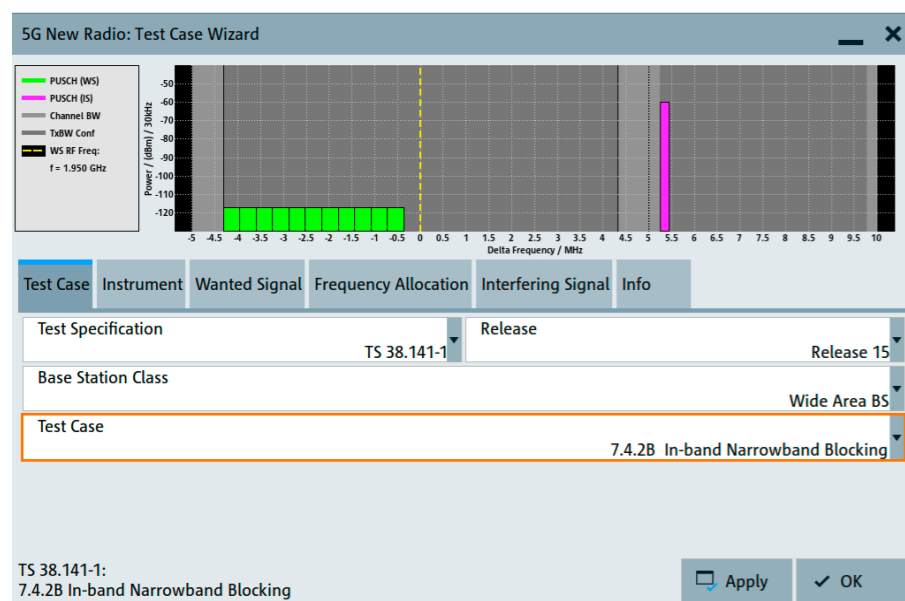

The 5G NR test case wizard allows the R&S®SMW200A to be configured conveniently and cleverly for BTS tests in line with 3GPP TS38.141. The wanted signal and interferer for a narrowband blocking test are set.

Test setup for envelope tracking with the R&S®SMW200A and the FSW

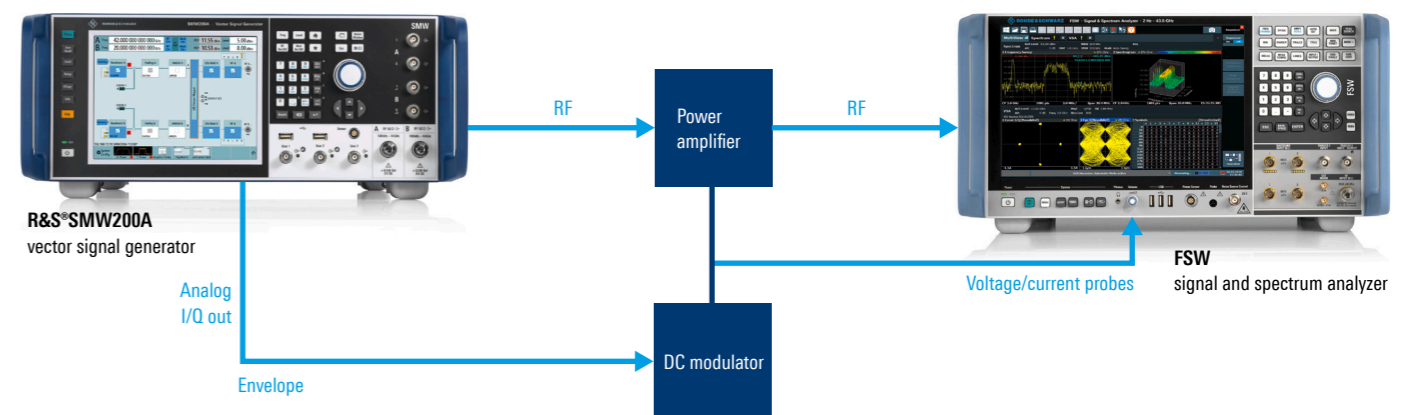

BRING REALITY TO YOUR LAB

Advanced, state-of-the-art channel emulation

The internal fading simulator option is another element that distinguishes the R&S®SMW200A from other RF vector signal generators. Using the latest FPGA technology, the hardware was designed for exceptional compactness so that up to four of the powerful fading modules can be installed. These modules can simultaneously emulate as many as 64 fading channels. The maximum fading bandwidth is 800 MHz. As a result, the R&S®SMW200A can realistically map even MIMO scenarios such as 3x3 MIMO for WLAN IEEE 802.11.

Inside buildings, there are more reflections than in open terrain. The time difference between different echoes is normally in the range of only a few nanoseconds. The instrument's time resolution of 2 ps and its ability to

simulate up to 20 paths per fading channel enable it to realistically simulate indoor fading scenarios. All in all, the R&S®SMW200A offers a fading performance that has so far only been achieved by significantly more expensive specialist instruments such as RF faders.

The user can select the fading scenarios required for all major standards directly from the predefined settings. In addition to classic multipath scenarios with Rayleigh, Rice or pure Doppler fading, the R&S®SMW200A can also simulate the dynamic scenarios specified in recent standards, such as birth-death, moving propagation and high speed train. Profiles for car-to-car communications are supported as well. All parameters can also be set manually, which makes it easy to implement user-specific fading configurations.

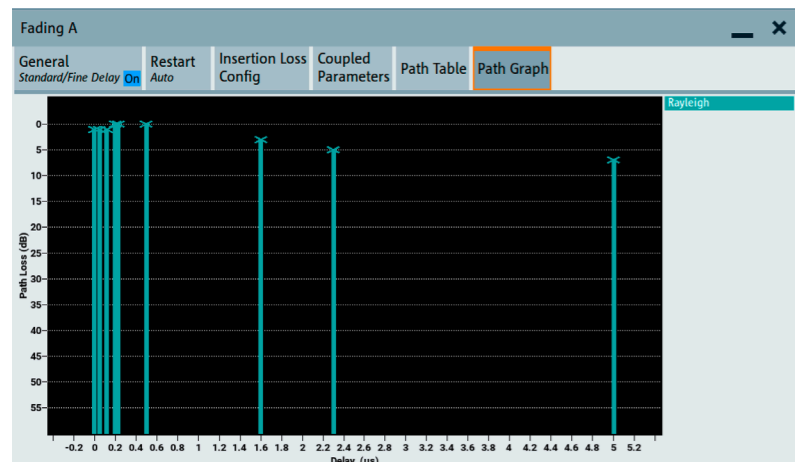

The fading settings of the R&S®SMW200A can be visualized to support the user. The screenshot shows the fading path configuration of an LTE ETU300 scenario.

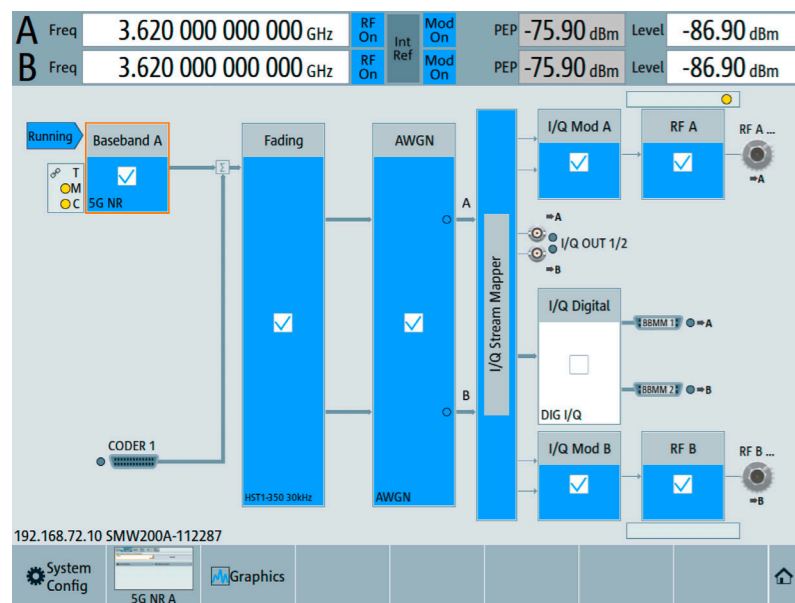

The R&S®SMW200A is perfect for 5G NR base station performance tests in line with 3GPP TS38.141. The block diagram (left) and fading settings (below) for testing with high speed train fading are shown.

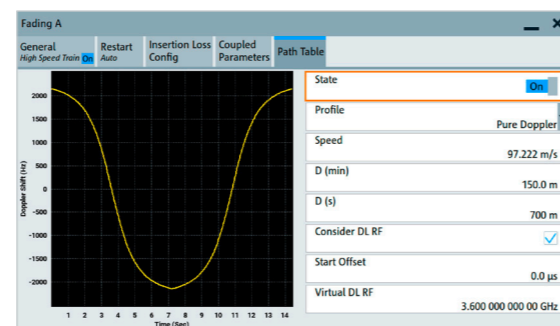

Prestigious discipline: MIMO

All modern wireless communications standards utilize MIMO technology to increase the effective data throughput. A test generator must be able to simulate MIMO scenarios exactly as they are present at the receive antennas of a receiver – even with complex MIMO receivers. This is where the multipath and fading capabilities of the R&S®SMW200A come into their own. The built-in baseband modules allow the simultaneous generation of up to eight signals. For MIMO scenarios, the signals from all transmit antennas – with antenna-specific coding – can be generated directly in a single instrument.

In addition, the R&S®SMW200A is able to simulate the entire MIMO channel. Up to 64 logical faders cover all key MIMO scenarios such as 3x3, 4x4, 8x4, 4x8 and 8x8. The user can also set the correlations between the propagation paths. Multistandard setups, such as simultaneous 2x2 MIMO for LTE and 3GPP FDD HSPA, are possible as well. Furthermore, carrier aggregation scenarios with four LTE component carriers (each with 2x2 MIMO) can be simulated with a single instrument. No matter how complicated the application, the R&S®SMW200A handles unique stimulus generation and channel simulation in parallel.

The R&S®SMW200A can be equipped with one or two internal RF paths. If necessary, more RF paths can be added: two additional I/Q-modulated R&S®SGT100A signal generator modules turn the R&S®SMW200A into an extremely compact complete 4x4 MIMO solution. Adding another four R&S®SGT100A modules enhances the solution to cover even 8x8 or 2x4x4 MIMO scenarios. The additional hardware is operated and remotely controlled directly from the R&S®SMW200A.

The R&S®SMW200A easily handles even complex MIMO setups. The global system configuration dialog can be used to reconfigure the signal generator in accordance

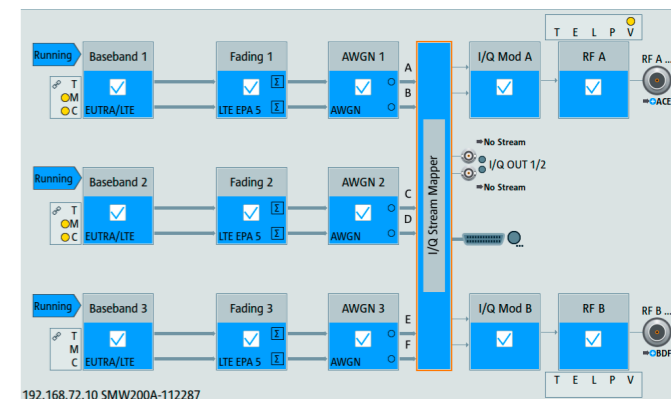

Block diagram of the R&S®SMW200A configured for the generation of an LTE Release 11 FeICIC test scenario. One R&S®SMW200A simultaneously generates the LTE serving cell as well as the two aggressor cells, each with 2x2 MIMO, with correlated fading channels.

with the required signal scenario. The block diagram on the GUI changes with the application so that the user can see at a glance which signal scenario is being generated. Every system configuration is accompanied by typical application examples. Users who need to go beyond standard configurations will also easily find an optimal scenario for their needs.

In the case of MIMO-capable standards such as 5G NR, LTE or WLAN, the transmit signals depend on each other. The R&S®SMW200A therefore features a shared menu (coupled sources mode) with which multi-antenna signals can be configured quickly and conveniently.

As an alternative, the signals can be set individually in the R&S®SMW200A (separate sources mode). This mode allows the simultaneous generation of signals for different standards, which makes the R&S®SMW200A ideal for testing multistandard base stations. Combinations (e.g. LTE, WCDMA and GSM) are possible as well as the use of user-defined ARB signals.

4x8 MIMO setup

4x8 MIMO setup, consisting of a two-path R&S®SMW200A and six R&S®SGT100A signal generator modules operated from the R&S®SMW200A. The modules provide RF paths 3 to 8. The R&S®SMW200A performs all the baseband signal generation and fading.

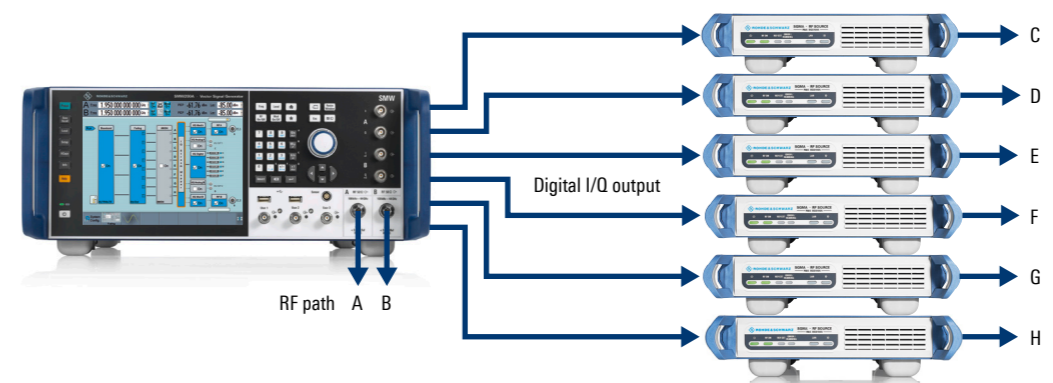

MAKE YOUR DEVICE EVEN BETTER

Excellent signal quality

Testing high-performance DUTs requires a signal generator solution that features significantly better RF characteristics than the DUT itself. Otherwise, the measurement results might be falsified by the signal generator. The R&S®SMW200A fully meets this requirement, enabling the DUT's entire potential to be utilized.

Exceptional modulation characteristics

The R&S®SMW200A features a wideband I/Q modulator with up to 2 GHz RF bandwidth. With this bandwidth, it covers practically all applications in its frequency range, including wireless and satellite communications, radar, research and education. The internal baseband makes

it possible to generate signals with a maximum width of 2 GHz. State-of-the-art D/A converters and an excellent RF chain ensure exceptional modulation characteristics. All in all, a modulation frequency response of < 0.4 dB (meas.) over 2 GHz bandwidth can be achieved. The R&S®SMW200A generates 5G NR signals (3.4 GHz carrier frequency, 100 MHz channel bandwidth, 64QAM) with an EVM of 0.1% (meas.) and WLAN IEEE 802.11be signals (7 GHz carrier frequency, 320 MHz channel bandwidth) with an EVM of -53 dB (meas.). Other signal types such as WCDMA, LTE, wideband QAM-modulated carriers and chirped pulses as well as multicarrier CW scenarios can also be output with the highest quality.

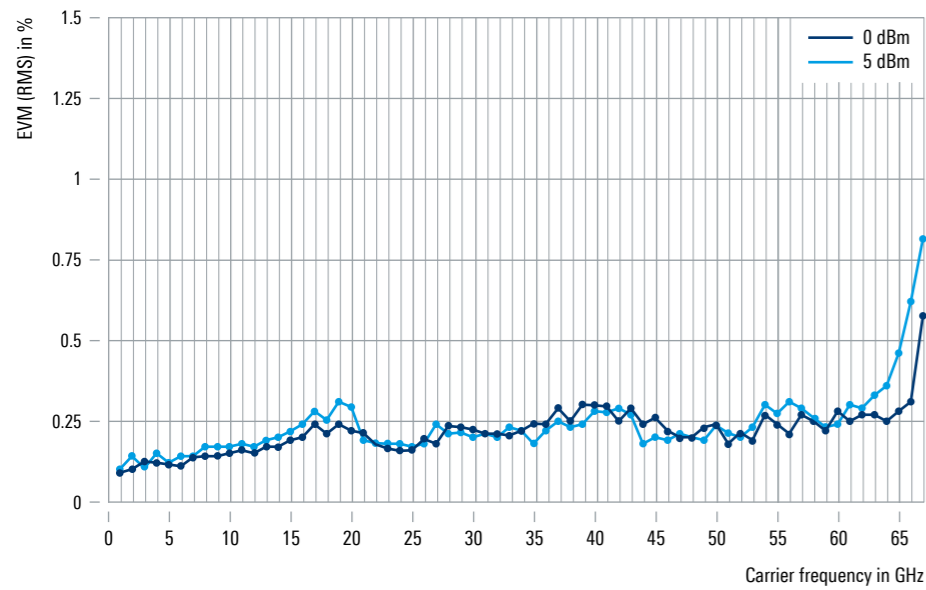

Measured EVM versus frequency for 5G NR, 100 MHz channel bandwidth

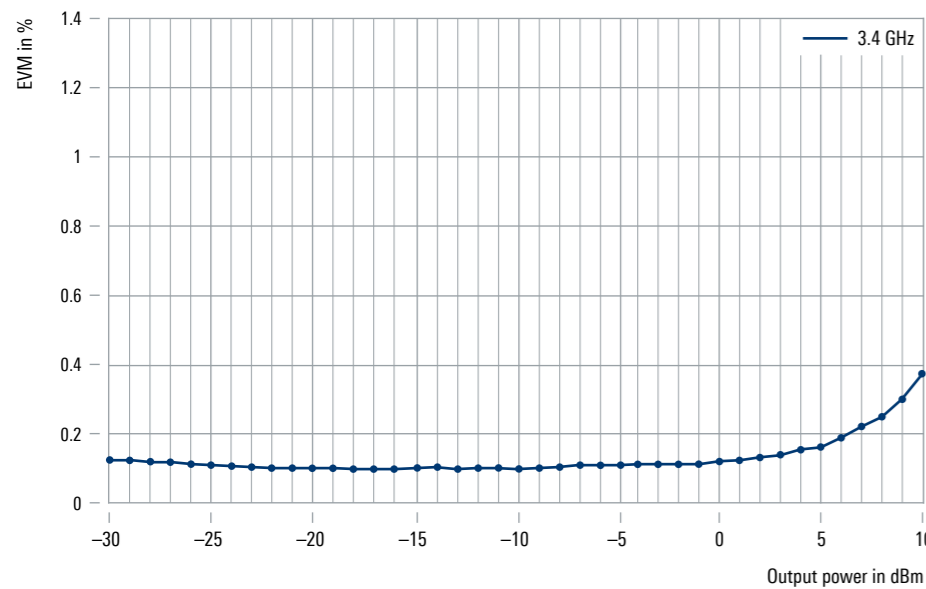

Measured EVM versus output power for 5G NR, 3.4 GHz carrier frequency, 100 MHz channel bandwidth, 64QAM, 60 kHz SCS

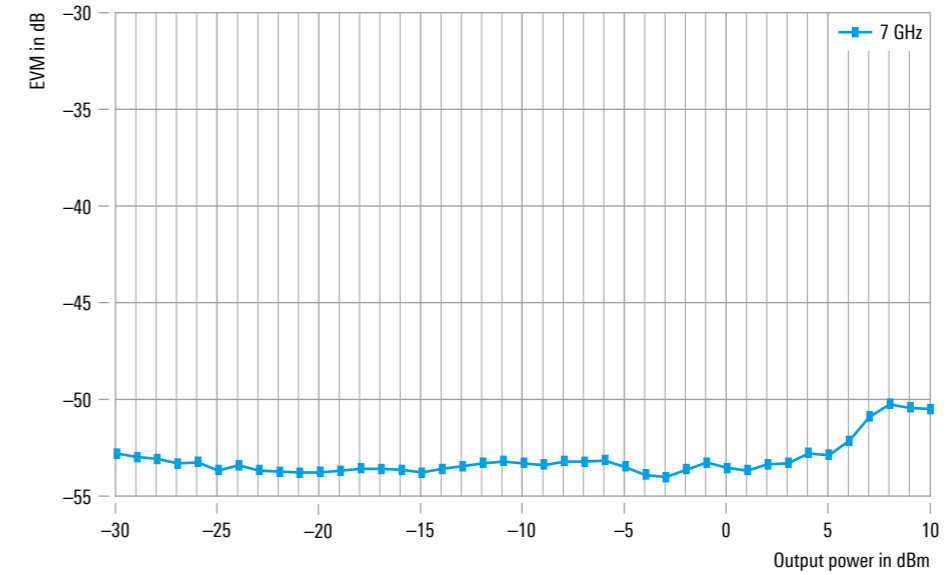

Measured EVM versus output power for IEEE 802.11be, 7 GHz carrier frequency, 320 MHz channel bandwidth, MCS13, 300 μs, Ch Estimation Seq Only

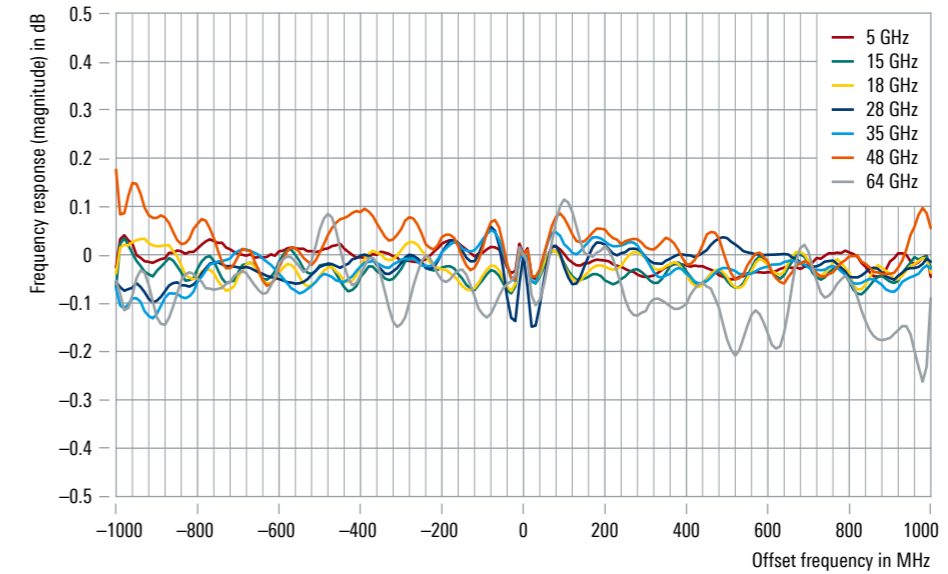

Measured I/Q modulation frequency response with internal wideband baseband

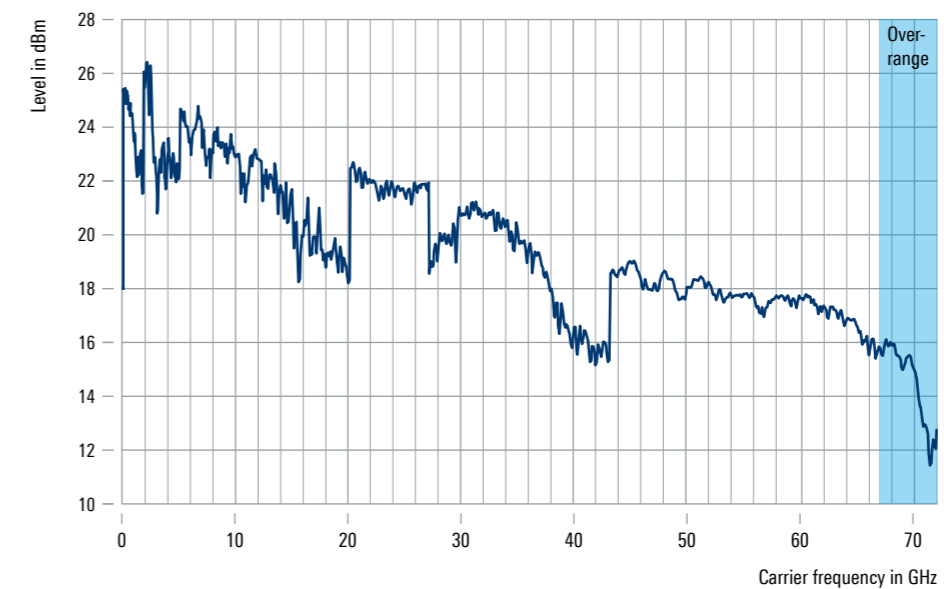

Measured maximum available output level versus frequency with R&S®SMW-B1067, R&S®SMW-B1067N, R&S®SMW-B10670 frequency options

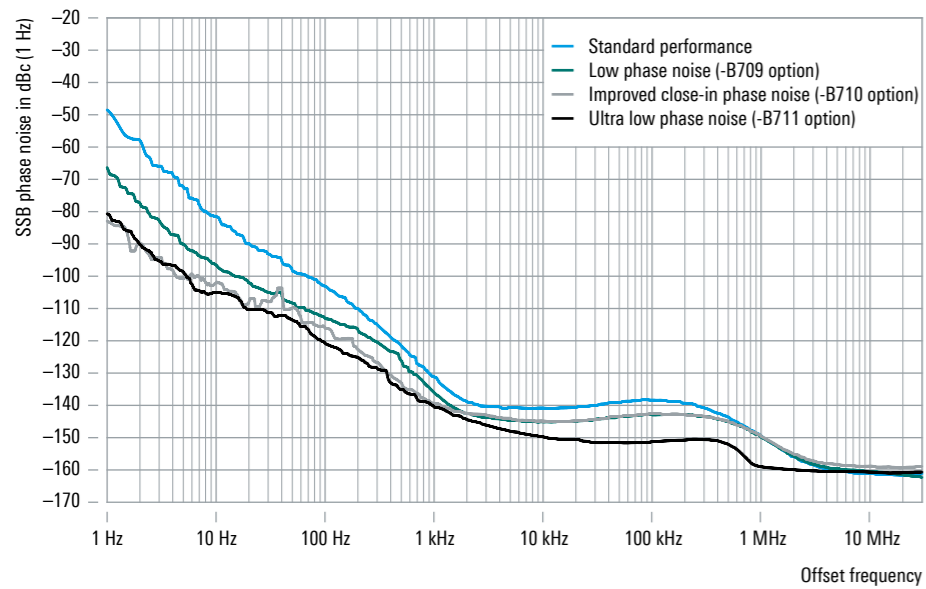

Measured SSB phase noise performance, 1 GHz carrier frequency, CW mode, standard performance versus the R&S®SMW-B709, R&S®SMW-B710 and R&S®SMW-B711 options

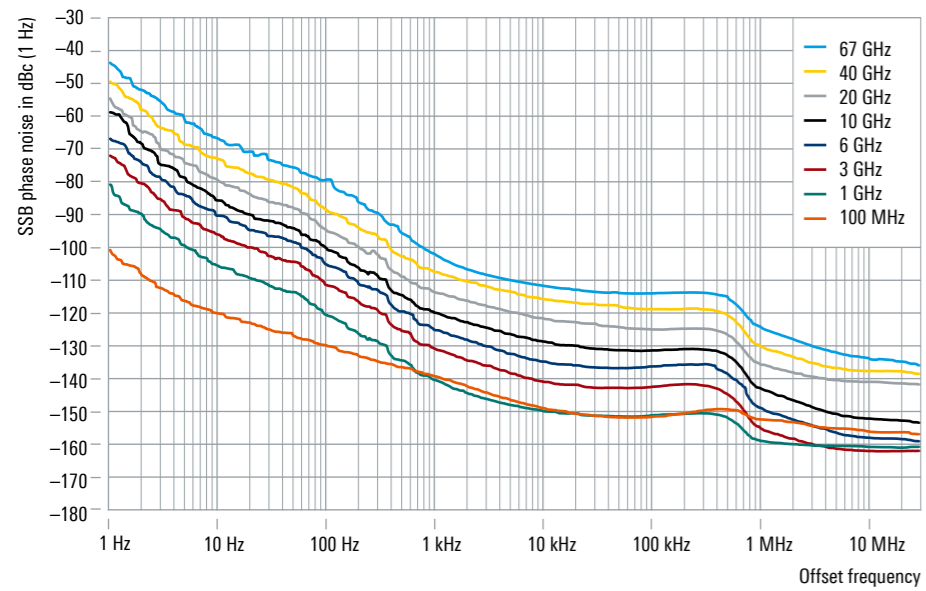

Measured SSB phase noise performance, with R&S®SMW-B711/-B721 options, CW mode

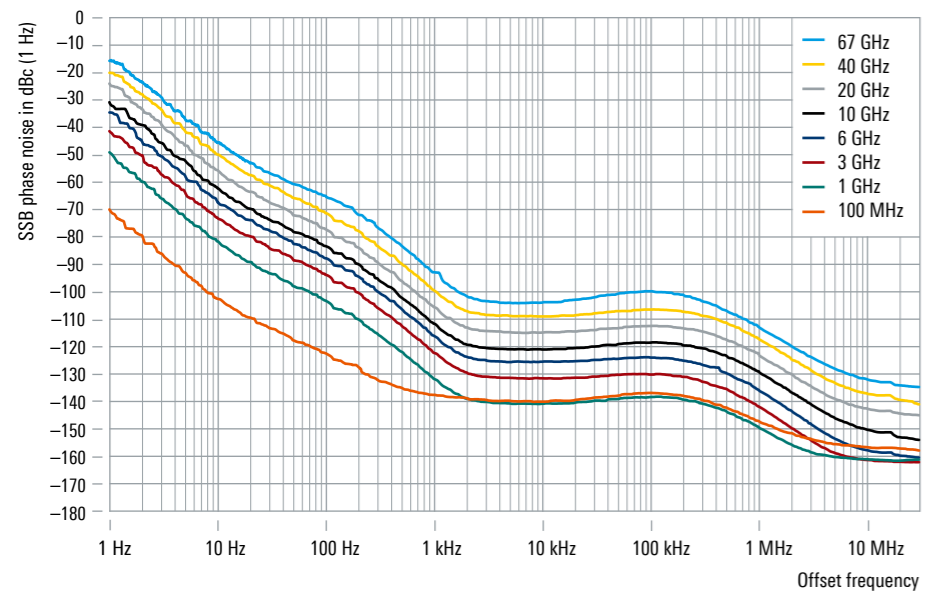

Measured SSB phase noise performance, standard instrument, CW mode

Very good RF characteristics

The RF characteristics of the R&S®SMW200A are simply impressive. The absolute level accuracy is better than 0.5 dB ($f \leq 3$ GHz) across the entire specified level range from -120 dBm to +18 dBm, without additional options being required. Frequency and level setting times of 600 μ s (typ.) via IEC/IEEE bus make the R&S®SMW200A the fastest high-end vector signal generator on the market and help save valuable time. Thanks to its excellent pulse modulator with on/off ratio > 80 dB and rise/fall time < 10 ns, the R&S®SMW200A is ideal for generating pulsed signals for radar applications.

The high-end synthesizer, which is included in the standard version of the R&S®SMW200A, already delivers exceptional SSB phase noise and nonharmonic values. The user can choose between several low phase noise options to improve performance even more. The R&S®SMW-B711/-B721 ultra low phase noise options provide the best possible performance for all carrier offsets. The R&S®SMW200A is perfect for measurements that place high requirements on spectral purity.

Phase-coherent signals up to 44 GHz

Beamforming applications, such as for measurements on active antenna systems, require high-quality phase-coherent test signals. More than just a common reference signal is usually needed to make sure that the relative phases remain stable over a long time period. The LO coupling offered by the R&S®SMW200A enables extremely precise and stable long-term phase synchronization of both generator paths. Up to 44 GHz, the generator can provide two phase-coherent RF paths in a single instrument without additional cabling. If more phase-coherent carriers are needed, the internal LO signal of the R&S®SMW200A can be connected to another R&S®SMW200A or an R&S®SGS100A or R&S®SGU100A signal generator module.

Setup for antenna testing

Setup with a two-path R&S®SMW200A, two R&S®SGS100A and two R&S®SGU100A to generate four phase-coherent CW or modulated signals, for example for antenna testing up to 20 GHz. The setup can be scaled to 40 GHz and duplicated if more RF paths are required.

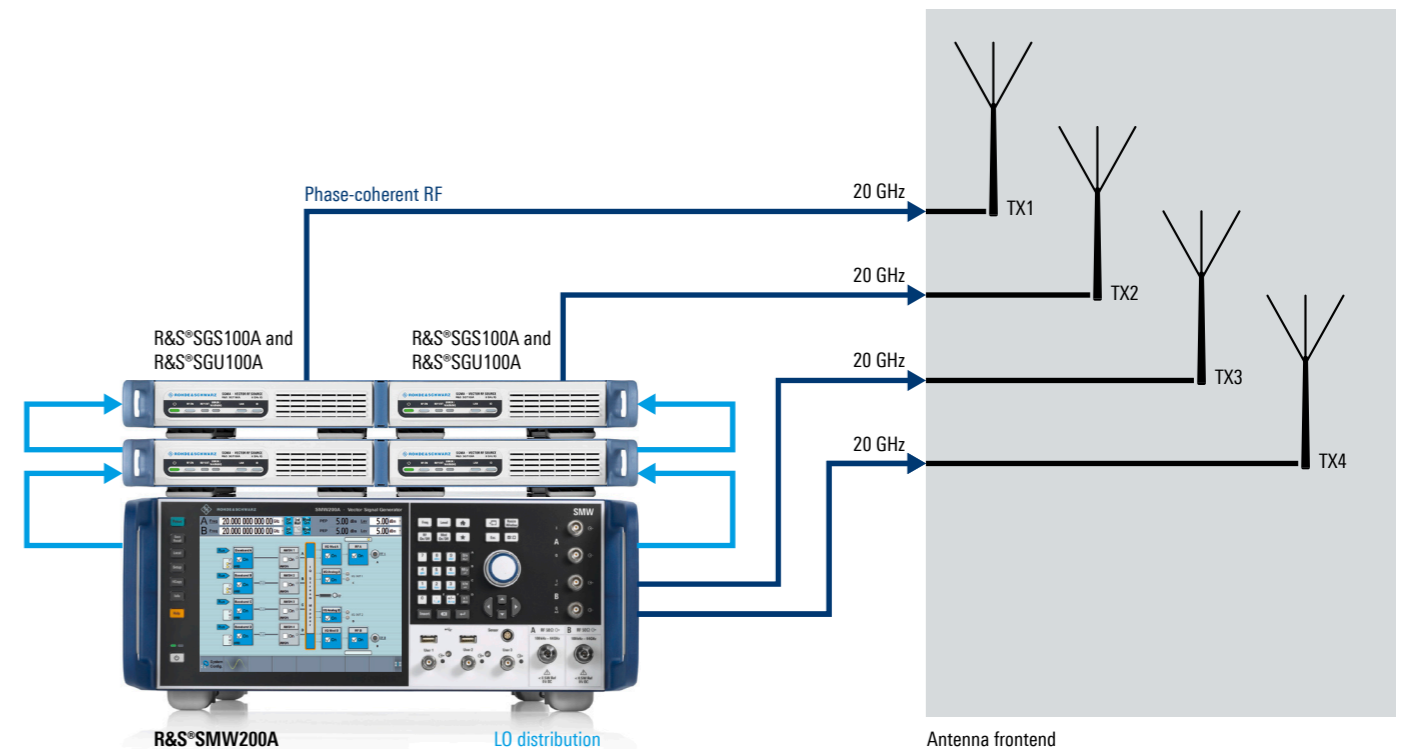

SPEED UP YOUR DEVELOPMENT

Increasing cost pressure results in ever shorter development cycles. At the same time, testing requirements are becoming more stringent. The R&S®SMW200A accomplishes complex measurement tasks quickly and efficiently. Numerous innovations in intuitive user guidance make work extremely easy.

Ergonomic design for maximum operating convenience

A high-resolution touchscreen and an easy-to-use graphical user interface ensure ergonomic operation. A block diagram provides a clear overview at all times. The user sees at a glance the signal flow and the status of all inputs and outputs. The drag and drop functionality makes signal flow reconfiguration simpler than ever. For MIMO and other complex applications, the block diagram is adapted to the signal scenario. All menus feature tabs for fast access to signal parameters. A context-sensitive online help system provides information about every parameter, such as setting range, detailed circuit description and SCPI command. Various functions facilitate everyday work, e.g. each parameter can be individually reset to its specific preset status.

The built-in graphics function of the R&S®SMW200A allows the generated signals to be displayed in real time in up to eight windows simultaneously. The user can select the type of display (I and Q versus time, frequency spectrum, vector diagram, etc.) and the point in the signal flow where the measurement will be performed.

The baseband measurement function allows real-time measurement of the level of a signal or signal component at defined points in the signal flow. This feature is

especially useful when the level of specific components of a complex signal is to be determined or varied during a measurement, for example in closed-loop scenarios.

Automation made easy

The R&S®SMW200A can be controlled via all common remote interfaces. The user benefits from a number of help functions when programming an automatic test sequence control. The SCPI commands for every setting parameter can be displayed directly and all modifications of the instrument's preset status can be highlighted graphically. This makes it easy to identify all parameters that are important for remote control.

The R&S®SMW200A also has a built-in SCPI macro recorder with code generator, which records all manual operating steps to generate a file with a remote command sequence. Code templates are provided for directly generating executable code for MATLAB and LabWindows/CVI. User-specific templates can also be used. As a result, the R&S®SMW200A contributes to minimizing the time required for test automation, saving development resources.

A fast instrument for speedy work

The Linux based operating system of the R&S®SMW200A helps ensure short boot times. The high computer performance speeds up work even when settings require comprehensive signal calculation.

MATLAB is registered trademark of The MathWorks, Inc.



The built-in SCPI macro recorder and code generator supports fast, convenient generation of SCPI program sequences

Context-sensitive online help system of the R&S®SMW200A

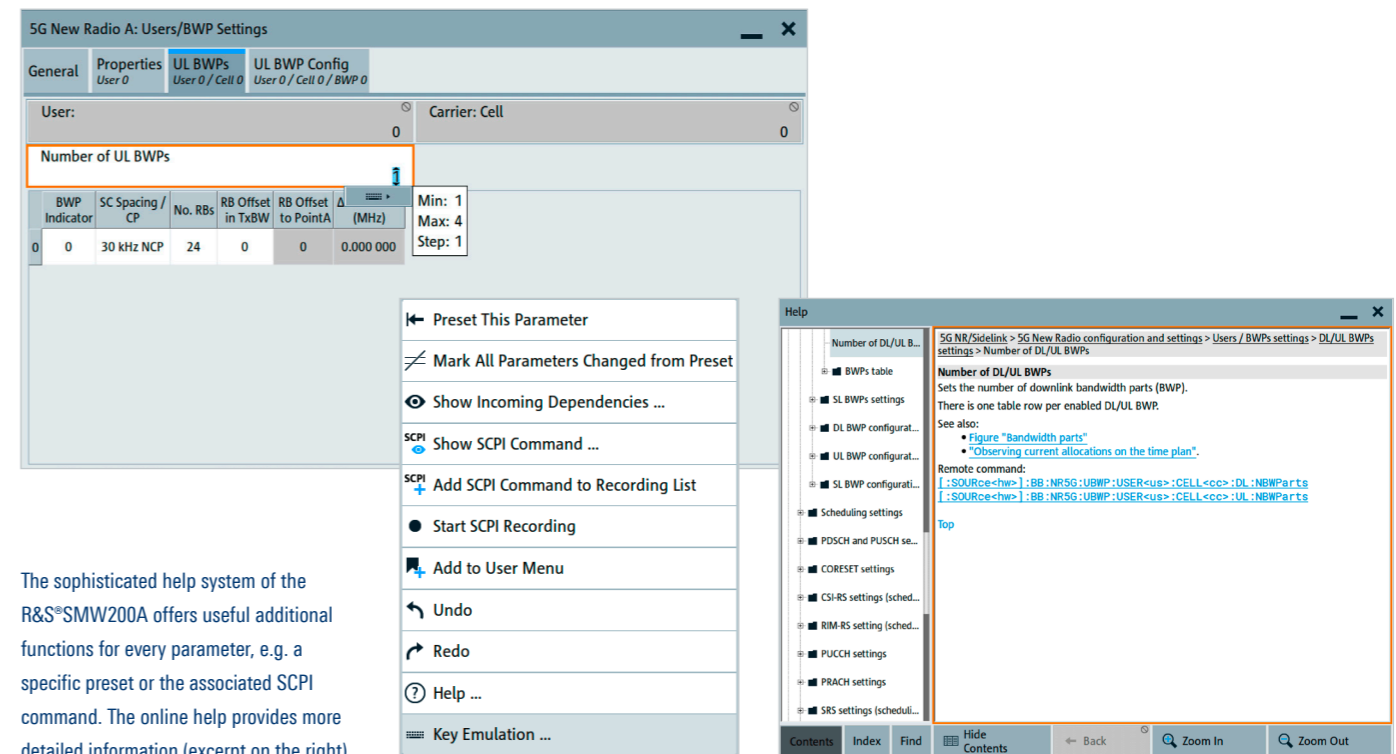

The sophisticated help system of the R&S®SMW200A offers useful additional functions for every parameter, e.g. a specific preset or the associated SCPI command. The online help provides more detailed information (excerpt on the right).

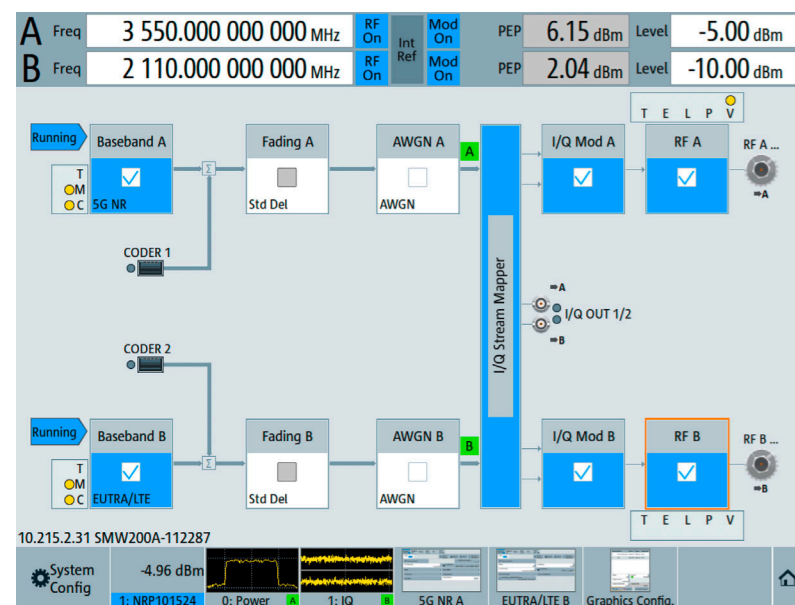

User interface of the R&S®SMW200A. The header shows the frequency, level and important instrument statuses. The footer provides quick access to open menus. The generated signals and the measurement results of any connected R&S®NRP-Zxx power sensor(s) can be displayed as well (second field from left in footer).

Graphical signal monitoring in real time

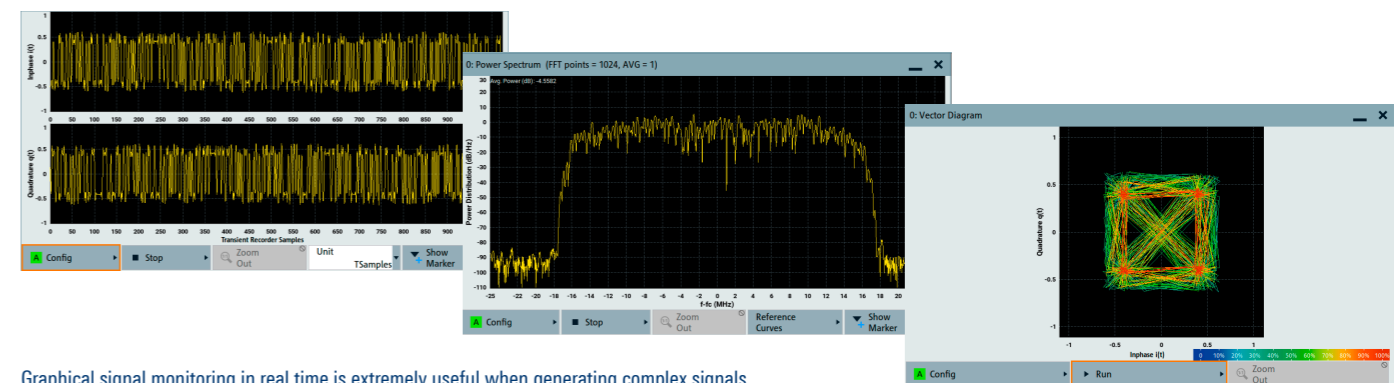

Graphical signal monitoring in real time is extremely useful when generating complex signals

GROWS WITH YOUR NEEDS

Advanced technology and a modular, upgradeable hardware concept make the R&S®SMW200A a future-ready investment.

R&S®SMW200A hardware options can be retrofitted with minimum effort. The baseband modules come as plug-ins and can easily be inserted into the rear panel without opening or recalibrating the instrument.

Software functions, e.g. digital standards, are simply activated via keycodes. The R&S®SMW200A firmware can be updated from a USB flash drive or via LAN. Free updates can be downloaded from www.rohde-schwarz.com/product/smw200a.

In this way, the R&S®SMW200A can be precisely customized to suit the applications at hand and enhanced whenever new requirements arise. Users only have to purchase what they currently need and are free to decide on upgrades depending on their future requirements.

The R&S®SMW200A can be upgraded with various hardware and software options. For example, a large variety of digital standards are offered as software options.

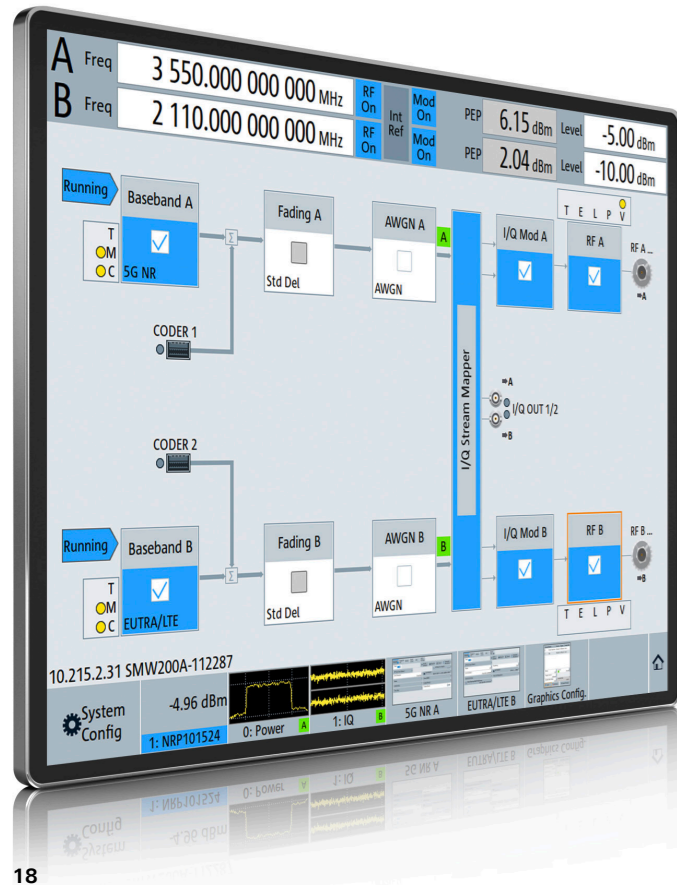

The R&S®SMW200A vector signal generator with an R&S®FE170ST external frontend generates high-quality modulated signals in the D band

The R&S®SMW200A can be used together with many other Rohde & Schwarz instruments

R&S®SMW200A function/connection	Related option(s)	Rohde & Schwarz partner instrument	Application example
RF output	R&S®SMW-K553	R&S®FExx external frontends, e.g. R&S®FE170ST	extended frequency range from 110 GHz to 170 GHz
Digital baseband output	R&S®SMW-K18/-K19	e.g. R&S®SGT100A signal generator module or R&S®SMCV100B vector signal generator	provides additional RF paths
Analog I/Q output	R&S®SMW-K16/-K17	e.g. R&S®SGS100A signal generator module	provides additional RF paths
R&S®NRP sensor connector	—	R&S®NRPxxS power sensors	high-precision power measurement, result display on the R&S®SMW200A

SPECIFICATIONS IN BRIEF

Specifications in brief		
Frequency		
Frequency range, RF path A	R&S®SMW-B1003	100 kHz to 3 GHz
	R&S®SMW-B1006	100 kHz to 6 GHz
	R&S®SMW-B1007	100 kHz to 7.5 GHz
	R&S®SMW-B1012	100 kHz to 12.75 GHz
	R&S®SMW-B1020	100 kHz to 20 GHz
	R&S®SMW-B1031	100 kHz to 31.8 GHz
	R&S®SMW-B1040/-B1040N	100 kHz to 40 GHz
	R&S®SMW-B1044/-B1044N/-B1044O	100 kHz to 44 GHz
	R&S®SMW-B1056/-B1056N/-B1056O	100 kHz to 56 GHz
	R&S®SMW-B1067/-B1067N/-B1067O	100 kHz to 67 GHz
Frequency range, RF path B (optional, see R&S®SMW200A specifications for possible RF path configurations)	R&S®SMW-B2003	100 kHz to 3 GHz
	R&S®SMW-B2006	100 kHz to 6 GHz
	R&S®SMW-B2007	100 kHz to 7.5 GHz
	R&S®SMW-B2012	100 kHz to 12.75 GHz
	R&S®SMW-B2020	100 kHz to 20 GHz
	R&S®SMW-B2031	100 kHz to 31.8 GHz
	R&S®SMW-B2044/-B2044N/-B2044O	100 kHz to 44 GHz
Level		
Specified level range	3 MHz ≤ f ≤ 20 GHz	-120 dBm to +18 dBm (PEP)
	R&S®SMW-B1031/-B1040/-B1040N/-B1044(N/O)/-B2020/-B2031/-B2044(N/O)	-120 dBm to +11 dBm/+18 dBm (PEP), depending on RF
	R&S®SMW-B1056(N/O)/-B1067(N/O)	-120 dBm to +9 dBm/+15 dBm (PEP), depending on RF
Spectral purity		
Harmonics	level < 10 dBm, CW	< -30 dBc
	R&S®SMW-B1020/-B1031/-B1040/-B1040N/-B1044(N/O)/-B2020/-B2031/-B2044(N/O), f > 3.5 GHz	< -55 dBc
	R&S®SMW-B1056(N/O)/-B1067(N/O), f > 3.5 GHz, level < 6 dBm	< -55 dBc
Nonharmonics	CW or vector modulation with full-scale DC input, 200 MHz < f ≤ 1500 MHz	level > -10 dBm, carrier offset > 10 kHz
	standard	< -85 dBc
	with R&S®SMW-B711/-B721 option	< -95 dBc
SSB phase noise	CW, carrier offset = 10 kHz, f = 1 GHz	
	standard	< -134 dBc
	with R&S®SMW-B709/-B719 option	< -139 dBc
	with R&S®SMW-B711/-B721 option	< -144 dBc, -150 dBc (typ.)
	CW, carrier offset = 10 kHz, f = 10 GHz	
	standard	< -114 dBc
	with R&S®SMW-B709/-B719 option	< -119 dBc
	with R&S®SMW-B711/-B721 option	< -124 dBc, -130 dBc (typ.)
Analog modulation		
Supported analog modulation modes	depending on options	AM, FM, φM, pulse

Specifications in brief

I/Q modulation		
RF modulation bandwidth	with internal wideband baseband, "I/Q wideband" on	
	1 MHz ≤ f ≤ 300 MHz	±32% of carrier frequency
	300 MHz < f ≤ 2.5 GHz	±40% of carrier frequency
	f > 2.5 GHz	±1 GHz
	with internal standard baseband, "I/Q wideband" on	
	1 MHz ≤ f ≤ 250 MHz	±32% of carrier frequency
	f > 250 MHz	±80 MHz
Modulation frequency response in specified RF modulation bandwidth	with internal baseband, "I/Q wideband" on	< 1.0 dB, < 0.4 dB (meas.)
EVM		
5G NR	100 MHz, 64QAM, f = 3.4 GHz	0.1% (meas.)
IEEE802.11be	320 MHz, f = 7 GHz	-53 dB (meas.)
Wideband baseband generator		
	R&S®SMW-B9 option, up to two wideband baseband generators can be installed	
Signal bandwidth	standard	500 MHz
	with R&S®SMW-K525 option	1 GHz
	with R&S®SMW-K525 and -K527 options	2 GHz
ARB memory depth	standard	256 Msample
	with R&S®SMW-K515 option	2 Gsample
Frequency offset	standard	-250 MHz to +250 MHz
	with R&S®SMW-K525 option	-500 MHz to +500 MHz
	with R&S®SMW-K525 and -K527 options	-1000 MHz to +1000 MHz
Standard baseband generator		
	R&S®SMW-B10 option, up to two baseband generators can be installed	
Signal bandwidth	standard	120 MHz
	with R&S®SMW-K522 option	160 MHz
ARB memory depth	standard	64 Msample
	with R&S®SMW-K511 option	512 Msample
	with R&S®SMW-K511 and -K512 options	1 Gsample
Frequency offset	standard	-60 MHz to +60 MHz
	with R&S®SMW-K522 option	-80 MHz to +80 MHz
Digital standards		
Supported standards and modulation systems		5G NR Releases 15 to 17, LTE Releases 8 to 15, NB-IoT, eMTC, 3GPP FDD/HSPA/HSPA+, GSM/EDGE/EDGE Evolution, WLAN IEEE 802.11a/b/g/n/j/p/ac/ax/ad/be, GNSS, AWGN and more
Fading and MIMO		
Fading simulator	R&S®SMW-B14/-B15 option, up to four fading modules can be installed	
Fading bandwidth	depending on options	max. 800 MHz
Fading channels	depending on options	max. 64
MIMO fading scenarios	depending on options	2x2, 3x3, 4x4, 8x4, 4x8, 8x8, 2x2x2, 2x4x4, 4x2x2 and more
Fading modes	depending on options	multipath, moving delay, birth-death, high speed train, two-channel interferer
Fading profiles	depending on options	Rayleigh, Rice, pure Doppler, static path, Gaussian, customized and more

For more information, see www.rohde-schwarz.com/product/smw200a and

- ▶ R&S®SMW200A specifications (PD 3606.8037.22)
- ▶ R&S®SMW200A configuration guide (PD 3606.8037.92)
- ▶ "Digital Standards for Signal Generators" specifications (PD 5213.9434.22)
- ▶ "GNSS and Avionics Simulation for Rohde&Schwarz Signal Generators" specifications (PD 3607.6896.22)
- ▶ "Multichannel, MIMO, Fading and Radar Echo Generation for the R&S®SMW200A" specifications (PD 3673.1276.22)

OPTIONS FOR DIGITAL COMMUNICATIONS STANDARDS (SELECTION)

Standard/technology	Options	Key features
5G NR	R&S®SMW-K144/-K145/-K148/-K170/-K171/-K175	<ul style="list-style-type: none"> ▶ In line with 3GPP Releases 15, 16 and 17 ▶ Downlink and uplink signals for FR1 and FR2 ▶ All numerologies and channel bandwidths ▶ Support of multiple bandwidth parts (BWP) with mixed numerology ▶ Support of uplink closed-loop base station tests in line with 3GPP TS38.141
LTE/LTE-Advanced	R&S®SMW-K55/-K69/-K81/-K84/-K85/-K112/-K113/-K119	<ul style="list-style-type: none"> ▶ In line with 3GPP LTE Releases 8, 9, 10, 11, 12, 13, 14, 15 ▶ FDD and TDD ▶ Downlink (OFDMA) and uplink (SC-FDMA) ▶ Carrier aggregation ▶ Support of uplink closed-loop base station tests in line with 3GPP TS36.141 ▶ LTE test case wizard
Cellular IoT	R&S®SMW-K115/-K143/-K146	<ul style="list-style-type: none"> ▶ In line with 3GPP Releases 13, 14, 15 ▶ NB-IoT and eMTC downlink and uplink signal generation ▶ NB-IoT in-band, guard band and standalone modes ▶ Real-time processing of HARQ feedback commands for closed-loop base station tests
3GPP FDD/HSPA/HSPA+	R&S®SMW-K42/-K83	<ul style="list-style-type: none"> ▶ In line with 3GPP FDD Release 11 ▶ Downlink and uplink ▶ HSDPA H-Sets ▶ Higher order modulation, MIMO, CPC ▶ Support of base station tests in line with 3GPP TS25.141 ▶ 3GPP test case wizard
DVB-S2/-S2X, DVB-RCS2	R&S®SMW-K116/-K169/-K176	<ul style="list-style-type: none"> ▶ Signals for component, payload and ground station testing ▶ DVB-S2X beam hopping and superframe signals in line with ETSI EN302307-2 V1.3.1, Annex E (2021) ▶ DVB-RCS2 implementation in line with ETSI EN301545-2 V1.3.1 Lower Layers for Satellite standard (2020-07)
IEEE802.15.4, HRP UWB and O-QPSK	R&S®SMW-K180/-149/-K181/-K182	<ul style="list-style-type: none"> ▶ Signal generation in line with IEEE802.15.4 ▶ Support of HRP-ERDEV in BPRF and HPRF mode ▶ Support of enhanced HRP UWB features in line with IEEE802.15.4ab (HRP-ARDEV, HRP-EMDEV, HRP-LLDDEV, HRP-SDEV) ▶ Support for O-QPSK narrowband signal generation in line with IEEE802.15.4ab
Bluetooth®	R&S®SMW-K60/-K117/-K178	<ul style="list-style-type: none"> ▶ Standard-compliant signal generation up to Bluetooth® 6.0 ▶ Bluetooth® basic rate (BR), Bluetooth® enhanced data rate (EDR), Bluetooth® low energy (LE) including channel sounding ▶ Dirty transmitters for receiver sensitivity test cases ▶ All transport modes, channel types, packet types and formats
WLAN, IEEE802.11a/b/g/n/j/p/ac/ax/be/bn	R&S®SMW-K54/-K86/-K142/-K147/-K185	<ul style="list-style-type: none"> ▶ Support of all mandatory physical layer modes ▶ EHT frames with up to 320 MHz transmission bandwidth ▶ BPSK, QPSK, 16QAM, 64QAM, 256QAM, 1024QAM and 4096QAM modulation ▶ MIMO modes with four transmit antennas ▶ Frame block sequencer for alternating legacy frames in line with IEEE802.11a/b/g/j/p, IEEE802.11n or IEEE802.11ac
WLAN, IEEE802.11ad/ay	R&S®SMW-K141/-K177	<ul style="list-style-type: none"> ▶ In line with IEEE802.11ad-2012 and IEEE802.11ay-2021 ▶ Support of control, single carrier, OFDM and low-power single carrier modes ▶ Modulation and coding schemes 0 to 31 ▶ Support of aggregated MPDUs
GNSS	R&S®SMW-K44/-K66/-K94/-K97/-K98/-K106/-K107/-K123/-K132	<ul style="list-style-type: none"> ▶ Support of GPS, GLONASS, Galileo, BeiDou, IRNSS and QZSS/SBAS, including hybrid constellations ▶ Real-time simulation of realistic constellations with unlimited simulation time ▶ Flexible scenario generation including moving scenarios, dynamic power control and atmospheric modeling ▶ Configuration of realistic user environments, including obscuration and multipath, antenna characteristics and vehicle attitude

The Bluetooth® word mark and logos are registered trademarks owned by Bluetooth SIG, Inc. and any use of such marks by Rohde & Schwarz is under license.

Service at Rohde & Schwarz

YOU'RE IN GREAT HANDS

	SERVICE PLANS	ON DEMAND
Calibration	Up to five years ¹⁾	Pay per calibration
Warranty and repair	Up to five years ¹⁾	Standard price repair

¹⁾ For extended periods, contact your Rohde & Schwarz sales office.

Instrument management made easy
The R&S®InstrumentManager makes it easy to register and manage your instruments. It lets you schedule calibration dates and book services.



Find out more about our service portfolio under:

Rear panel of the R&S®SMW200A



Service at Rohde & Schwarz
You're in great hands

- ▶ Worldwide
- ▶ Local and personalized
- ▶ Customized and flexible
- ▶ Uncompromising quality
- ▶ Long-term dependability

MAKE IDEAS REAL
and join our experts team
at Rohde & Schwarz.



Rohde & Schwarz

The Rohde & Schwarz technology group is among the trailblazers when it comes to paving the way for a safer and connected world with its leading solutions in test & measurement, technology systems and networks & cybersecurity. Founded more than 90 years ago, the group is a reliable partner for industry and government customers around the globe. The independent company is headquartered in Munich, Germany and has an extensive sales and service network with locations in more than 70 countries.

www.rohde-schwarz.com

Sustainable product design

- ▶ Environmental compatibility and eco-footprint
- ▶ Energy efficiency and low emissions
- ▶ Longevity and optimized total cost of ownership

Certified Quality Management
ISO 9001

Certified Environmental Management
ISO 14001

More certificates of Rohde & Schwarz



Rohde & Schwarz training

www.training.rohde-schwarz.com

Rohde & Schwarz customer support

www.rohde-schwarz.com/support

