



REAL TIME CROSS CORRELATION



RoHS

HA7062C

PHASE NOISE ANALYZER

10MHz to 6GHz

0.1Hz to 40MHz Bandwidth

Real Time Data Acquisition

DATA SHEET – November 2020



Holzworth

PRODUCT SUMMARY

The **HA7062C Real Time Phase Noise Analyzer** is born from Holzworth's history of industry leading phase noise analyzers with proven accuracy, high reliability, automation and flexibility. The real time engine covers the full measurement bandwidth with extremely fast measurement speeds to reduce product development time and optimizes ATE manufacturing throughput.

MEASURED NOISE FLOORS: Like the HA7062C, competitive designs provide a *measurement confidence factor*, which is often misinterpreted as the noise floor of the instrument. Holzworth is the only company that has architected the instrument's front end so that the noise floor limits can actually be measured (refer to pages 7-10).

UNPARALLELED ANALOG PERFORMANCE: The HA7062C has high speed, real time dual FFT engines at its core, but everything starts at the analog front end. A key component of the analog front end is a pair of Holzworth HSX Series RF Synthesizers as the test system's internal LOs. These ultra low noise RF sources not only complement the real time FFT core to provide one of the most advanced phase noise analyzers available, but they are also made available as general purpose CW sources at the front panel *LO Output* ports.

REPEATABLE DATA: Holzworth's fully shielded, fan-less 1U chassis eliminates ground loops and troublesome microphonics for uncompromised performance and repeatability. See it for yourself knowing that Holzworth encourages running head-head tests with the competition.

REAL TIME FULL BANDWIDTH DATA ACQUISITION**VERSATILE - RECONFIGURABLE FRONT END****MEASURE: PM / AM / BASEBAND / SPURIOUS / JITTER****ISOLATED AM/PM MEASUREMENTS****AUTOMATED RESIDUAL MEASUREMENTS****MEASURABLE ULTRA LOW PHASE NOISE FLOORS****3 YEAR MANUFACTURER WARRANTY**

PRODUCT SUMMARY - BLOCK DIAGRAM

VERSATILE: The HA7062C is a result of more than a decade of product development reflecting valuable customer feedback and Holzworth's direct experience with measuring phase noise in our own manufacturing environment. The end result goes well beyond accuracy, reliability and speed... the reconfigurable front end allows users to tailor the analyzer for their specific measurement needs.

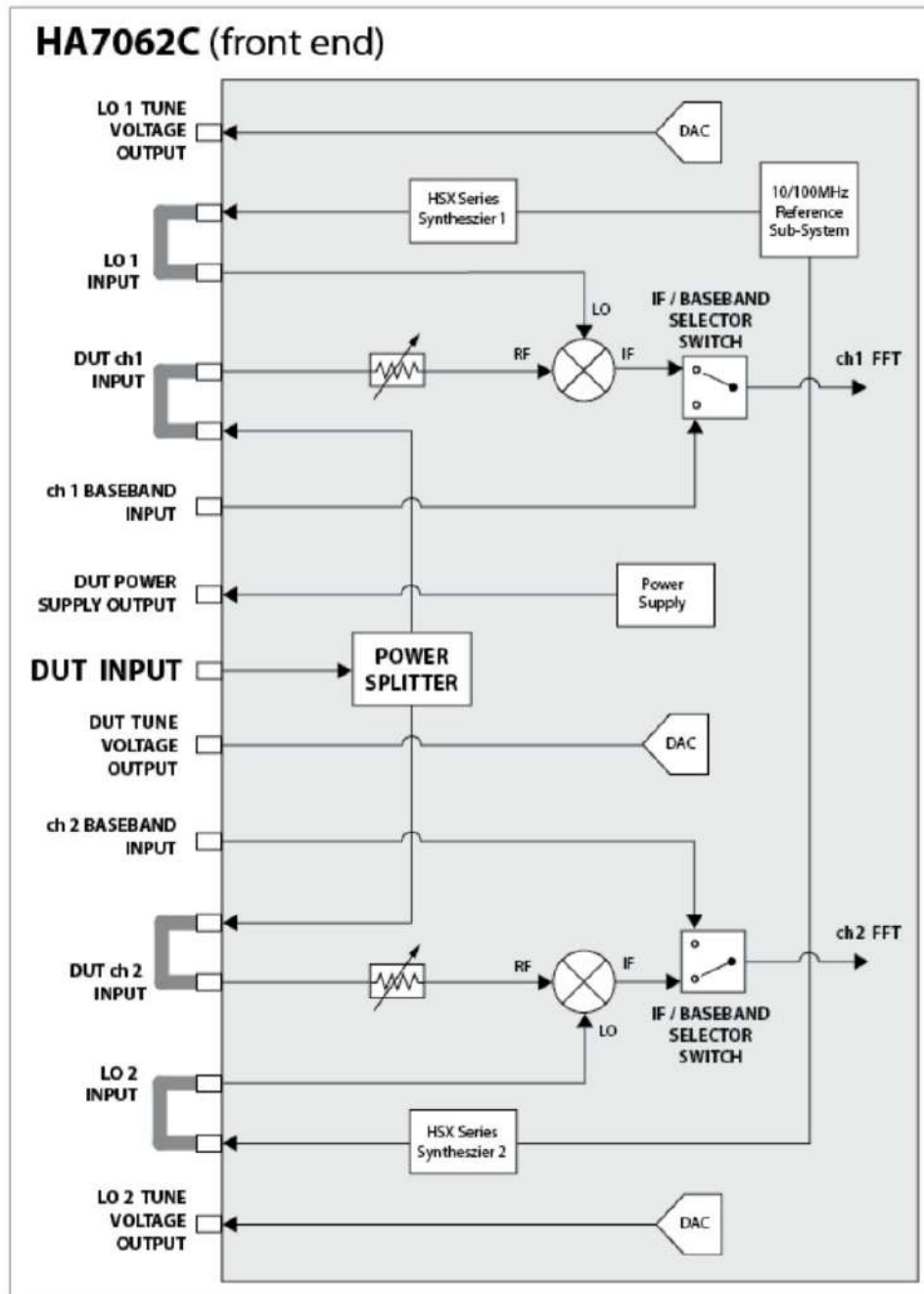

Figure 1: HA7062C Front End Block Diagram

HA7062C SPECIFICATIONS

The specifications outlined here capture the baseline performance and features that are currently available from the HA7062C phase noise analyzer. The hardware is capable of additional functionality for custom requirements. Inquire with Holzworth Instrumentation or your local sales representative.

MEASUREMENT MODES

MODE	DESCRIPTION
Internal LO Mode	Internal synthesized LO sources. Auto tune and phase lock Connect DUT Signal direct to HA7063A.
External LO Mode	External LO Inputs for user supplied LO's. Auto tune and phase lock.
Additive Mode	Multi port device measurements. External Signal Source and phase shifters required.
AM Noise Measurements	Characterize AM noise of RF input signal
Spurious Analysis Toolbox	Provides spurious performance data based on a user settable Spur Threshold.

DUT INPUT

DESCRIPTION	SPECIFICATION
DUT Input Connector	SMA (female), 50 ohm
DUT Input Frequency Range	10 MHz to 6 GHz
DUT Input Measurement Level 10 MHz to MAX FREQ	-5 dBm to +20 dBm
DUT Input Damage Level	+22dBm
DUT Input VSWR	< 2.0:1
RF Tracking Range	± 10 ppm (typical), ± 5 ppm (specified)
Cross-Correlation Noise Floor	Refer to pages 7-10 for measured noise floor data.

MEASUREMENT BANDWIDTH & UNCERTAINTY

DESCRIPTION	SPECIFICATION
Offset Frequency Range PM Measurements AM Measurements Baseband Measurements	0.1 Hz to 40 MHz 0.1 Hz to 1 MHz 0.1 Hz to 40 MHz
Phase Noise Uncertainty (Absolute Measurements) 1 Hz to 10 Hz offset 10 Hz to 1 kHz offset 1 kHz to 40 MHz offset	± 4 dB ± 3 dB ± 2 dB
Phase Noise Uncertainty (Additive Measurements) 1 Hz to 1 kHz offset 1 kHz to 40 MHz offset	± 3 dB ± 2 dB

AMPLITUDE NOISE MEASUREMENTS

DESCRIPTION	SPECIFICATION
RF Input Frequency Range	10 MHz – 6 GHz
Offset Frequency Range	0.1 Hz – 1 MHz

INTERNAL TIME BASE (10MHz Reference)

DESCRIPTION	SPECIFICATION
Frequency Uncertainty / Stability	$< \pm 1$ Hz at 10 MHz (± 100 ppb) At time of shipment. Factory calibrated at +21C.
Frequency Temperature Effects	< 10 ppb
Frequency Aging Rate	< 10 0ppb/yr
10MHz External Lock Range	± 20 Hz (typical), ± 10 Hz (specified). 10 MHz is for frequency counters only.

POWER METER ACCURACY

PARAMETER	MIN	TYPICAL	MAX	COMMENTS
Input Power Meter Accuracy 10MHz to MAX FREQ		± 1 dB		

SPECIFICATIONS - ELECTRICAL (continued)
TABLE 1: MEASUREMENT SPEED (SAMPLE TIME) vs. MINIMUM OFFSET

1 Cross-Correlation									
64 Samples		128 Samples		256 Samples		512 Samples		1024 Samples	
-	-	-	-	0.1Hz	17s	0.1Hz	34s	0.1Hz	1m8s
1Hz	1.1s	1Hz	2.2s	1Hz	4.3s	1Hz	8.6s	1Hz	17s
10Hz	0.3s	10Hz	0.5s	10Hz	1.1s	10Hz	2.2s	10Hz	4.3s
100Hz	0.1s	100Hz	0.1s	100Hz	0.3s	100Hz	0.5s	100Hz	1.1s
1kHz	<0.1s	1kHz	<0.1s	1kHz	0.1s	1kHz	0.1s	1kHz	0.3s
10kHz	<0.1s	10kHz	<0.1s	10kHz	<0.1s	10kHz	<0.1s	10kHz	<0.1s
100kHz	<0.1s	100kHz	<0.1s	100kHz	<0.1s	100kHz	<0.1s	100kHz	<0.1s
1MHz	<0.1s	1MHz	<0.1s	1MHz	<0.1s	1MHz	<0.1s	1MHz	<0.1s

10 Cross-Correlations									
64 Samples		128 Samples		256 Samples		512 Samples		1024 Samples	
-	-	-	-	0.1Hz	2m51s	0.1Hz	5m42s	0.1Hz	11m24s
1Hz	11s	1Hz	21s	1Hz	43s	1Hz	1m25s	1Hz	2m51s
10Hz	2.7s	10Hz	5.4s	10Hz	11s	10Hz	22s	10Hz	43s
100Hz	0.7s	100Hz	1.3s	100Hz	2.7s	100Hz	5.4s	100Hz	11s
1kHz	0.2s	1kHz	0.3s	1kHz	0.7s	1kHz	1.3s	1kHz	2.7s
10kHz	<0.1s	10kHz	<0.1s	10kHz	0.1s	10kHz	0.2s	10kHz	0.3s
100kHz	<0.1s	100kHz	<0.1s	100kHz	<0.1s	100kHz	<0.1s	100kHz	<0.1s
1MHz	<0.1s	1MHz	<0.1s	1MHz	<0.1s	1MHz	<0.1s	1MHz	<0.1s

TABLE 2: CROSS-CORRELATIONS vs. PHASE NOISE IMPROVEMENT

Improvement factor: dB = 5logN (N = No. of correlations)

Number of Correlations	1	10	100	1,000	10,000
dB Improvement	0dB	5dB	10dB	15dB	20dB

NOISE FLOOR MEASUREMENT SETUP

The unique architecture of the HA7062C allows for direct access to key internal modules in order to measure the actual noise floor of the analyzer at any given frequency vs. minimum frequency offset and number of correlations. As with Holzworth, competitive phase noise analyzers offer a cross correlation confidence factor, which is an only approximation based on the data being taken at the time. The confidence factor is not the actual noise floor of the system.

To perform a noise floor measurement, the internal power splitter is bypassed to directly access the phase detector (mixer) of each channel/core while measuring two non-correlated frequency sources at the frequency of interest. Refer to Figure 2, below.

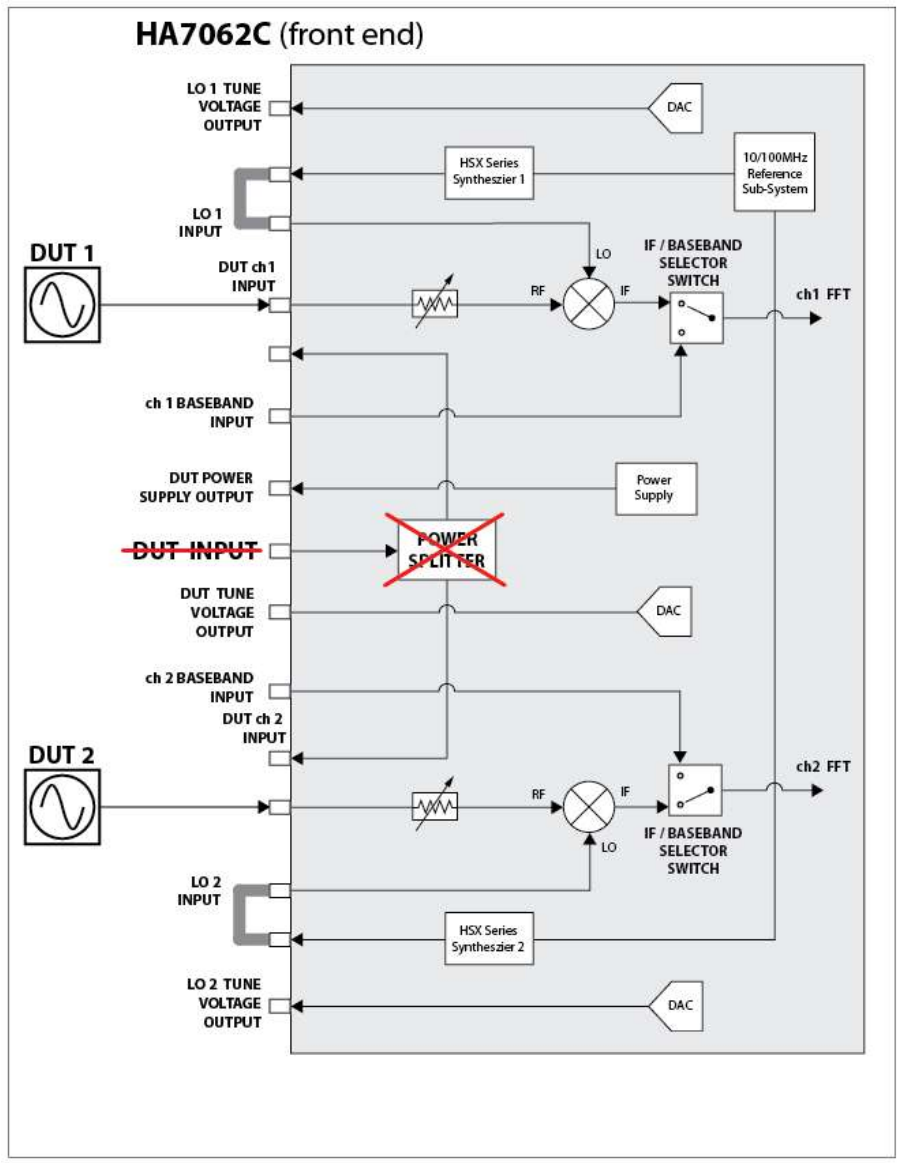

Figure 2: HA7062C Noise Floor Measurement Block Diagram

NOISE FLOOR DATA

The data contained in this section demonstrates the noise floor capability of the HA7062C at five different frequencies covering the base operating range of the instrument (10MHz, 100MHz, 1GHz, 3GHz and 6GHz). The three plots in each figure reflect an example of the actual noise floor for 1x, 10x and 100x correlations on a specific unit. An important note is that all analyzers will exhibit varying phase noise floors from unit to unit, hence the importance of being able to measure the true noise floor of an analyzer. Further improvement in the noise floor can be achieved by utilizing even more correlations (refer to Table 2, located on page 6).

All data contained in this section was acquired using a minimum offset frequency of 1Hz and data resolution of 256 points per decade. For reference, the data acquisition times for each measurement are as follows:

- 1 correlation: 4.3s**
- 10 correlations: 43s**
- 100 correlations: 7 min, 9s**

NOTE: Setting the instrument to a higher minimum offset frequency and/or to a lower data resolution setting will improve the measurement speed.

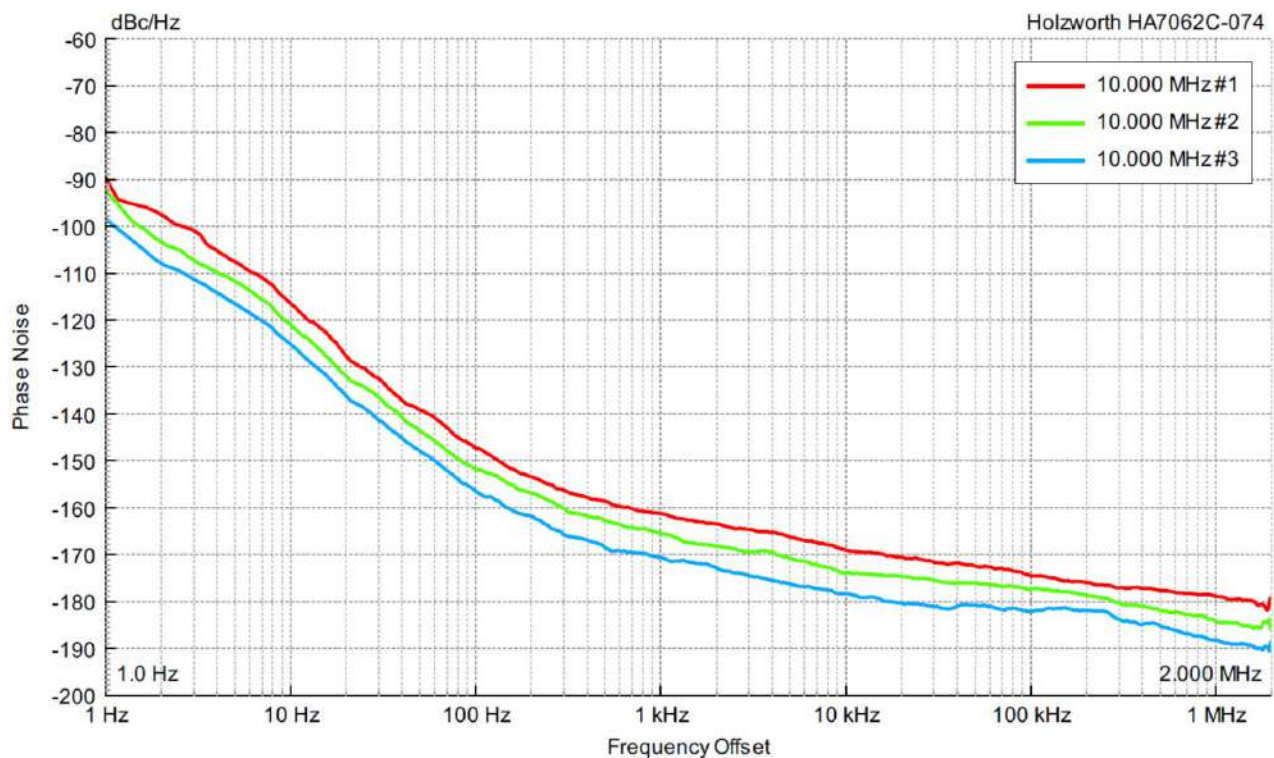

Figure 3: 10MHz Noise Floor Measurements

NOISE FLOOR DATA (continued)

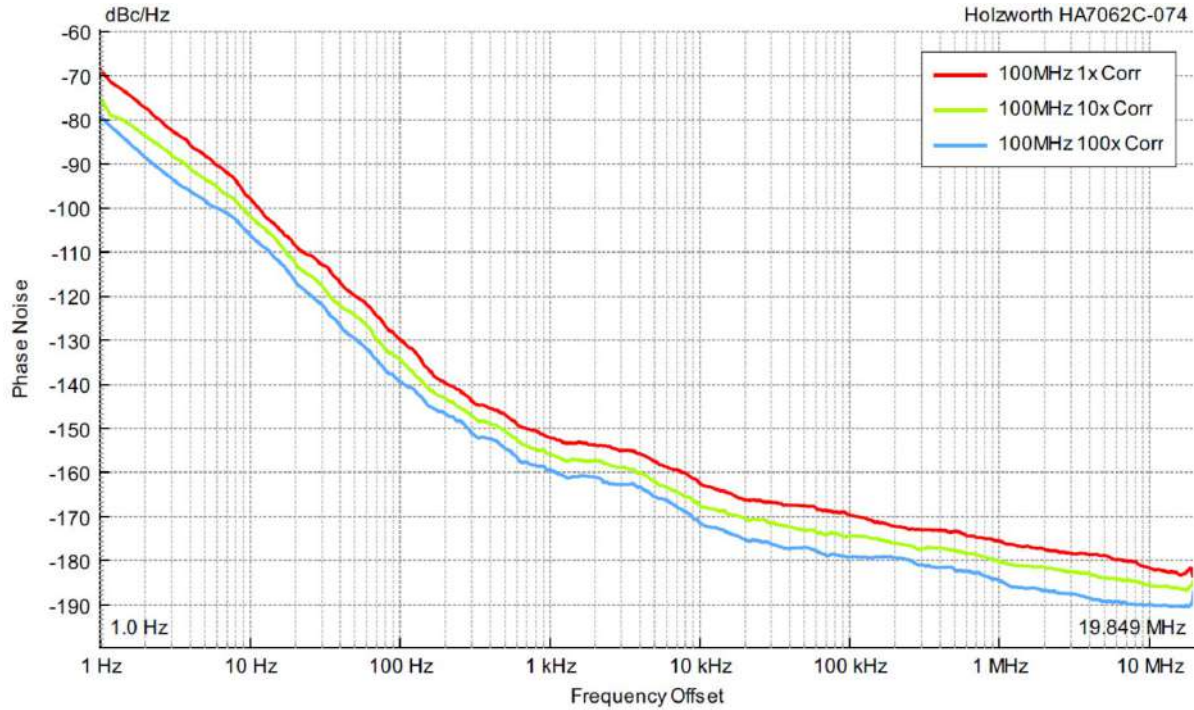

Figure 4: 100MHz Noise Floor Measurements

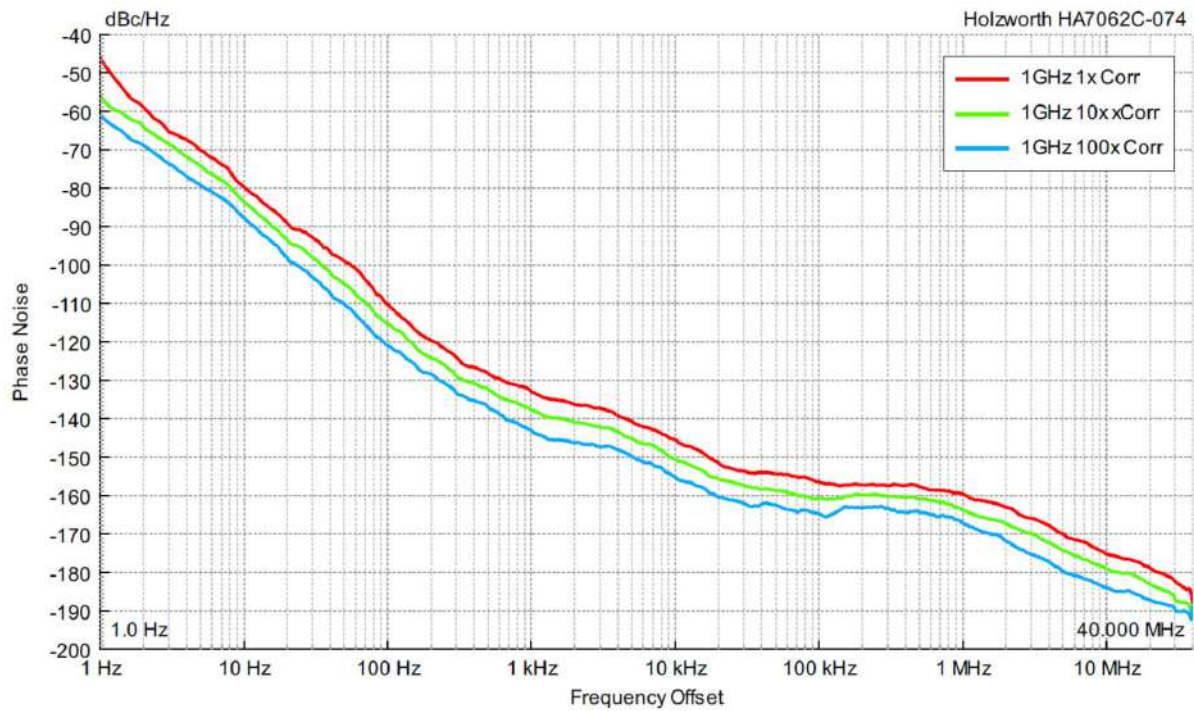

Figure 5: 1GHz Noise Floor Measurements

NOISE FLOOR DATA (continued)

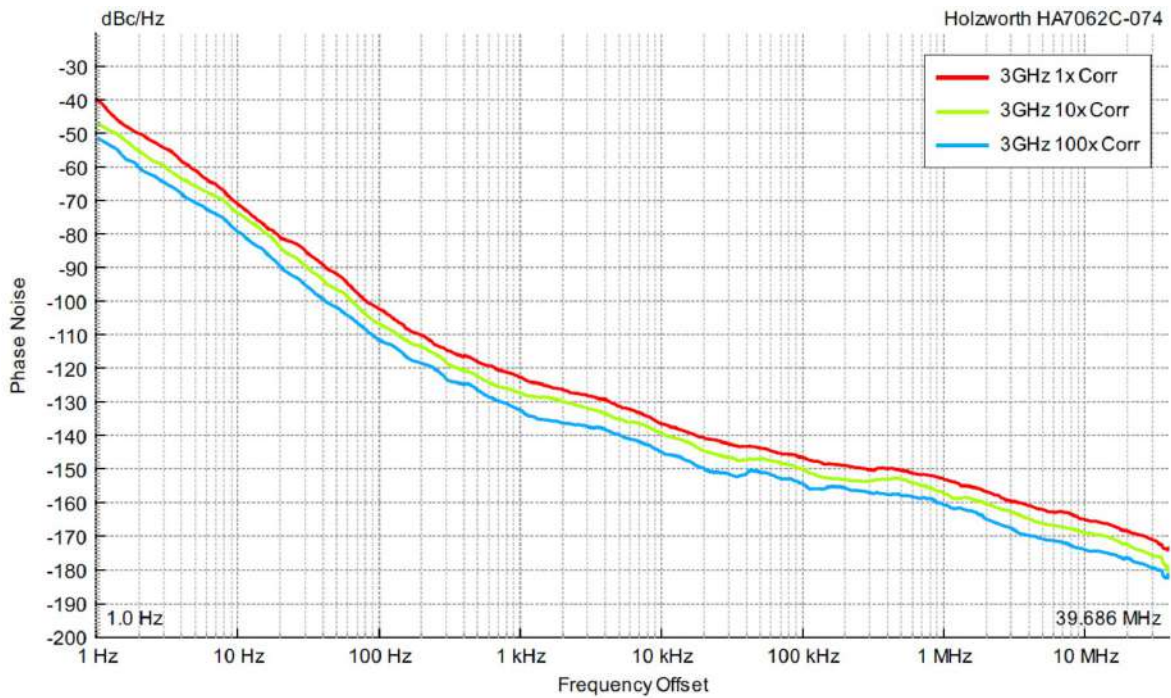

Figure 6: 3GHz Noise Floor Measurements

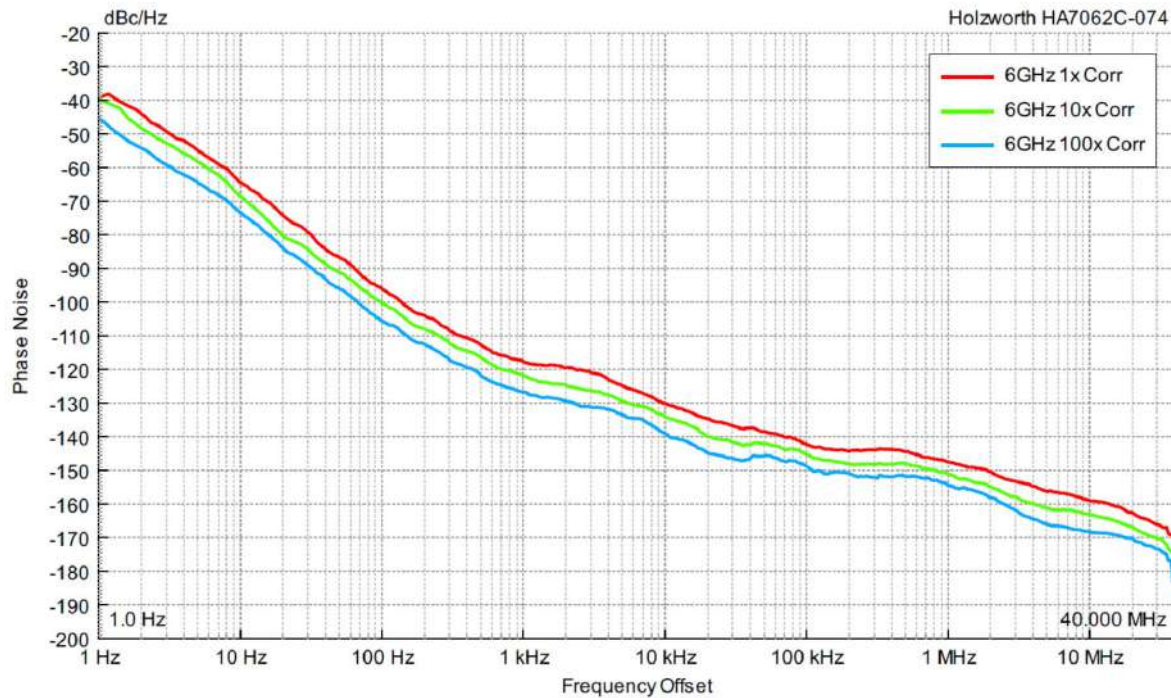

Figure 7: 6GHz Noise Floor Measurements

HA7062C CONFIGURATION
FRONT PANEL

The HA7062C allows for a high level of measurement flexibility to accommodate different test scenarios by allowing the user access to various system input points. However, only the *DUT Input* port is necessary for making straight forward absolute phase noise measurements of a frequency source.

DESCRIPTION	SPECIFICATION
Front Panel Connector(s) Type DUT Input (Standard) All Others	SMA, 50 ohm SMA, 50 ohm
DUT Input Frequency Range (standard) Power Level Range Input Damage Level	10 MHz to 6 GHz -5 dBm to +20 dBm +22 dBm
DUT Tune Voltage Voltage Tune Range Max Current	For Vcc control of some DUTs. -10 V to +12 V 5 mA
DUT Power Supply Voltage Supply Range Maximum Current	Integrated power supply. 0 V to +1.2V 250 mA
LO1/LO2 Input(s) Frequency Range (standard) Power Level Range Input Damage Level	Connect to <i>LO1/LO2 Output(s)</i> for standard operation. 10 MHz to 6 GHz +3 dBm to +13 dBm > +16 dBm
LO1/LO2 Output(s) Frequency Range (standard) Power Level Range	CW outputs for general purpose use. Connect to <i>LO1/LO2 Input(s)</i> for standard operation. 10 MHz to 6 GHz (0.001 Hz step size) 0 dBm to +10 dBm (0.01 dB step size)
LO1/LO2 Tune Voltage Voltage Tune Range Max Current	For independent Vcc control of external LO sources during External LO Mode of operation. -10 V to +12 V 5 mA
DUT ch1/ch2 Input(s) Frequency Range (standard) Power Level Range Input Damage Level	Allows bypass of DUT power splitter for direct access to the phase detector of each channel. 10 MHz to 6 GHz 0 dBm to +14 dBm > +16 dBm
ch1/ch2 Splitter Bypass Output(s)	Connect jumper cable to ch1/ch2 <i>DUT Input(s)</i> for standard operation.
ch1/ch2 Baseband Input(s) Frequency Range Power Level Range Input Damage Level	0.1 Hz to 100 MHz ± 1 Vdc ± 2 Vdc, or 50 mA (whichever is greater), +10 dBm RF power

CONFIGURATION (continued)
REAR PANEL

DESCRIPTION	SPECIFICATION
Reference Output Port Connector Type Output Frequency Output Level Output Waveform	SMA, 50ohm 10MHz \pm 10Hz +5dBm \pm 2dBm Sinusoid
10MHz Reference Input Port Connector Type Input Frequency Input Level	ONLY FOR FREQUENCY COUNTERS - DOES NOT AFFECT MEASUREMENT SENSITIVITY SMA, 50ohm 10MHz \pm 10Hz 0dBm to +10dBm (Sinusoid or Square)
AC Power Input Connector Type AC Input Rating	International Power Supply IEC 320-C13 90-260V _{AC} , 50-60Hz. Specify country at time of order for proper power cord.
Data I/O Interface Connectivity Storage	USB B-Type (virtual comm. port), Ethernet, RS-232, GPIB SD Card Reader

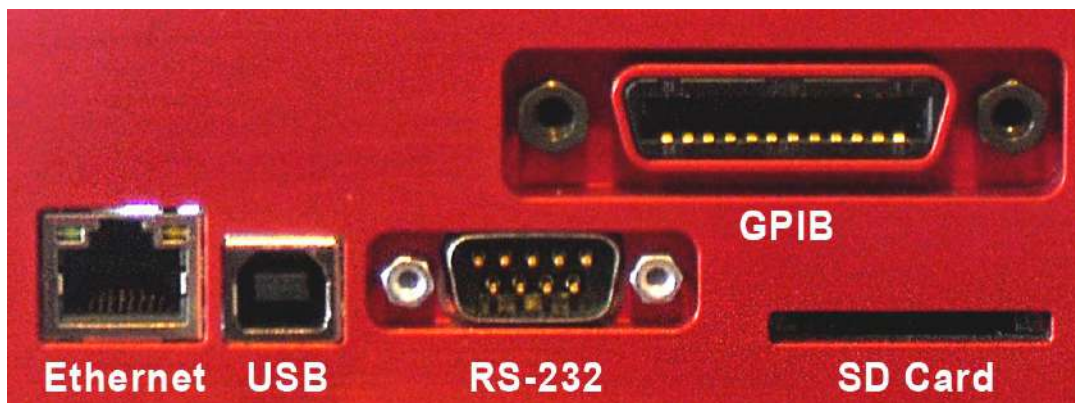
Figure 8: HA7062C Communication Ports

CONFIGURATION (continued)

MECHANICAL DIMENSIONS

The HA7062C has a 1U high, rack mountable chassis form factor. The fan-less design was adopted to eliminate the potential for microphonics. A universal rack mount bracket kit is an available accessory. Mechanical dimensions are listed in inches (and millimeters).

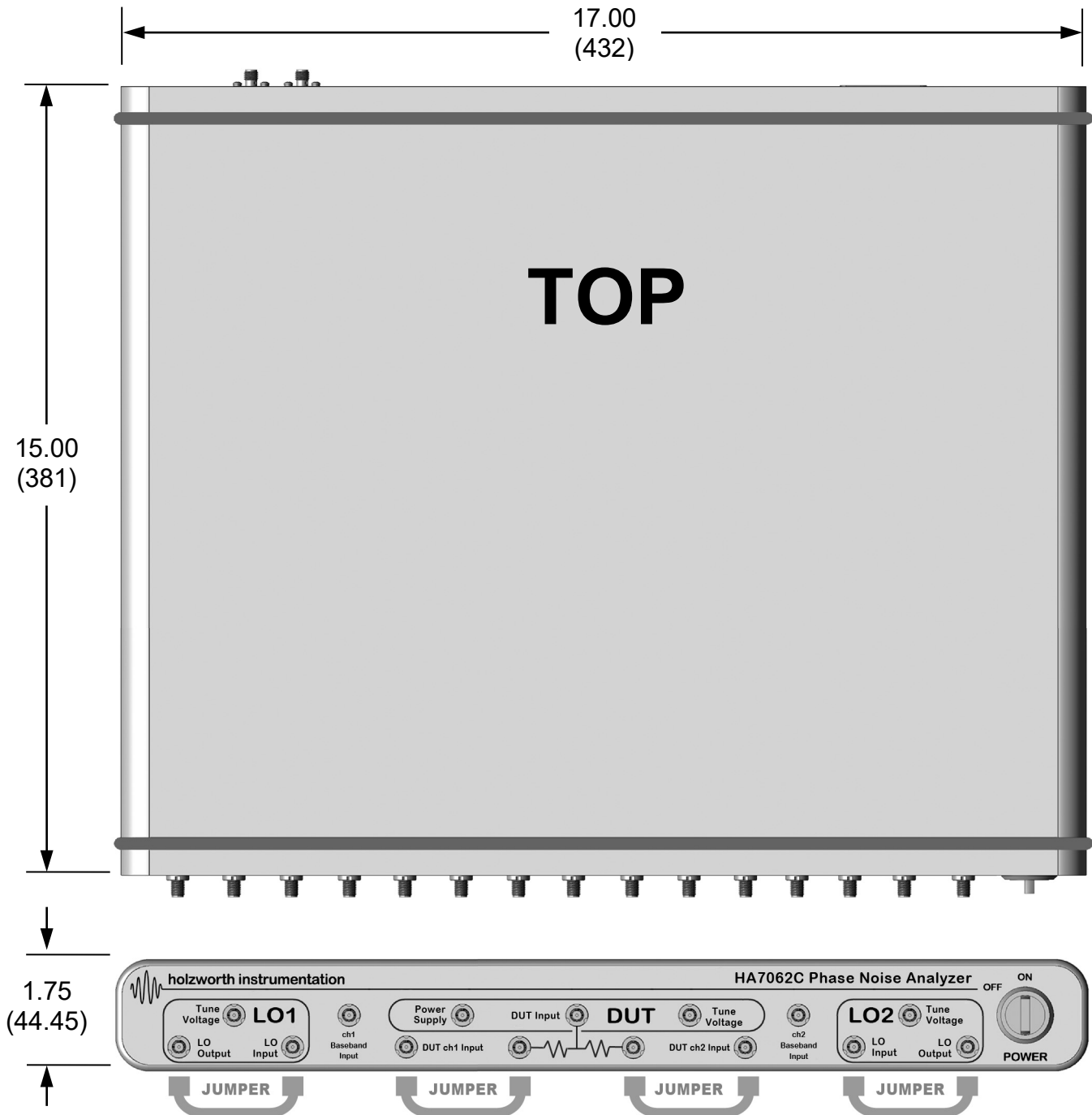

CONFIGURATION (continued)

AC POWER SUPPLY

The HA7062C utilizes an ultra-clean, international, switching power supply. Units ship with a country specific, AC supply cable. Please specify country of end use at the time of purchase.



ENVIRONMENTAL

DESCRIPTION	SPECIFICATION (by design)
Operating Environment Temperature Humidity Altitude Vibration	+10C to +40C RH 20% to 80% at wet bulb temp. <29C (non-condensing) 0 to 2,000m (0 to 6,561 feet) 0.21 G-rms maximum, 5Hz to 500Hz
Storage (Non-Operating) Temperature Humidity Altitude Vibration	-10C to + 60C RH 20% to 80% at wet bulb temp. <40C (non-condensing) 0 to 4,572m (0 to 15,000 feet) 0.5 G-rms maximum, 5Hz to 500Hz

CONFIGURATION (continued)
OPTIONS & ACCESSORIES

Holzworth offers options and accessories to optimize the analyzer for an intended application. Specify all required options and/or accessories when requesting a quotation or placing a purchase order.

PART No.	DESCRIPTION	CLASSIFICATION
HA7063A	50GHz Downconverter (ISO17025, see page 19)	ACCESSORY
HX4920	24GHz Frequency Divider (Divide-by-4 Component, see pages 20 – 21, 23)	ACCESSORY
HX5100-x	Electronic Phase Shifters. Additive Measurements, 1 Octave Bandwidth, Specify fc	ACCESSORY
CASE-1U	Ruggedized Carrying Case with TSA security lock	ACCESSORY
RACK-1U	19" Rack mount bracket kit for HA7000 Series. 90 degree rear bracket. 24in maximum.	ACCESSORY
RACK-1U-L	19" Rack mount bracket kit for HA7000 Series. 90 degree rear bracket. 29in maximum.	ACCESSORY
RACK2-1U	19" Rack mount bracket kit for HA7000 Series. Straight rear bracket. 24in maximum.	ACCESSORY
RACK2-1U-L	19" Rack mount bracket kit for HA7000 Series. Straight rear bracket. 29in maximum.	ACCESSORY

INCLUDED HARDWARE AND CERTIFICATIONS

Each standard product delivery includes specific, standard hardware and certifications.

TYPE	DESCRIPTION	COMMENTS
HARDWARE	HA7062C PHASE NOISE ANALYZER	DELIVERABLE
HARDWARE	AC Power Cord (7ft/2.1m). Specify country of end use.	DELIVERABLE
HARDWARE	Ethernet Cable (10ft/3m)	DELIVERABLE
HARDWARE	USB Cable (6ft/1.8m)	DELIVERABLE
WARRANTY	3 YEAR MANUFACTURER'S WARRANTY	NON-APPLICABLE
CERTIFICATE	CE COMPLIANCE CERTIFICATE <i>DIRECTIVE: 2004/108/EC, TEST STANDARD: EN 61326-1: 2006</i>	WEB DOWNLOAD
CERTIFICATE	RoHS COMPLIANCE CERTIFICATE <i>DIRECTIVE: 2002/95/EC</i>	WEB DOWNLOAD
CERTIFICATE	WEEE COMPLIANCE STATEMENT <i>DIRECTIVE: 2002/96/EC</i>	WEB DOWNLOAD

HA7062C OPERATION

All data processing is performed internally on the HA7062C. Measurement settings can be changed using serial commands sent to the HA7062C via any of the included communication protocols (see *Rear Panel Configuration* on page 14). Measurement results can be read back directly from the instrument, eliminating the use of the GUI software. This capability provides unparalleled operational flexibility, ideal for ATE applications.

Purchase of an HA7062C includes access to the C++ based GUI for hardware operation and viewing/saving data. All software upgrades and functionality additions are freely available for the life of the instrument at no additional cost to the user.

HA7062C SOFTWARE

The HA7062C GUI offers an extremely user-friendly means to utilize the full functionality of the HA7062C on any Windows-based PC. Absolute, Additive, Jitter, AM Noise, and more can be performed using the intuitive software GUI. Refer to the software menu summaries on page 17.



HA7062C SOFTWARE (continued)

The software menus indicated on page 16 are summarized as follows:

1. **File:** Save, load, export, import data; and generate reports. The report generator captures the current plot and any measurement statistics (see page 18).
Tools: Quick access to the Tune Voltage outputs on the analyzer and displays input frequency and power for either LO1, LO2, or the DUT port.
System: Create instrument setting presets (saving time for commonly used measurement setups), view/save measurement debug files, and manually perform firmware updates.
2. **Acquire / +:** The 'Acquire' button initiates/stops a phase noise measurement. When the '+' button is depressed, selecting 'Acquire' will overlay a new measurement to the existing data captured in the plot area with each new acquisition.
3. **Devices:** 'Devices' allows the user to view any HA7062C analyzer directly connected to the PC (USB or Ethernet) or over a LAN connection (Ethernet only) for multi-device control. Available devices are selected by part number/serial number.
4. **Measurement:** Make changes to measurement type, offset range, jitter parameters, number of correlations, *etc.*
5. **Inputs:** Used to verify DUT/LO power and frequency, calibrate and make adjustments for both internal and external LO sources.
6. **Outputs:** Provides tune control for the DUT Power Supply, DUT Tune Voltage, External LO Tune range and Internal LO power levels.
7. **Trace/Calcs:** Access to smoothing and spur removal functions to a data modify data markers. This sub-menu also contains the spurious analysis toolbox.
8. **Limits:** Apply test limit lines to the plot area for indicating pass/fail conditions.
9. **Markers:** Adjust the number of data markers, their locations and behavior.
10. **Display:** Provides access to plot data plot area modifications. Used to edit the x/y axis ranges, plot title, axis titles, trace names, plot export options, *etc.*
11. **Console:** The Console displays a log of instrument/measurement activity while also allowing the user to send commands directly to the instrument.
12. **Data Plot Area:** Displays acquired data: PM, AM, baseband, spurious, *etc.*
13. **Status Indicator:** The Holzworth logo shockwave doubles as a status bar/indicator while measurements are in progress. A measurement countdown timer is also displayed above the shockwave.
14. **Measurement Statistics:** Displays statistics of an active measurement or currently of a specifically selected data trace.

HA7062C SOFTWARE REPORT GENERATION

The automated report generation tool is a convenient feature for quickly generating a preformatted report that captures all traces and applicable data that is currently being displayed by the GUI. Each data trace actively contained in the plot area will be included in the report and color coordinated with its corresponding data.

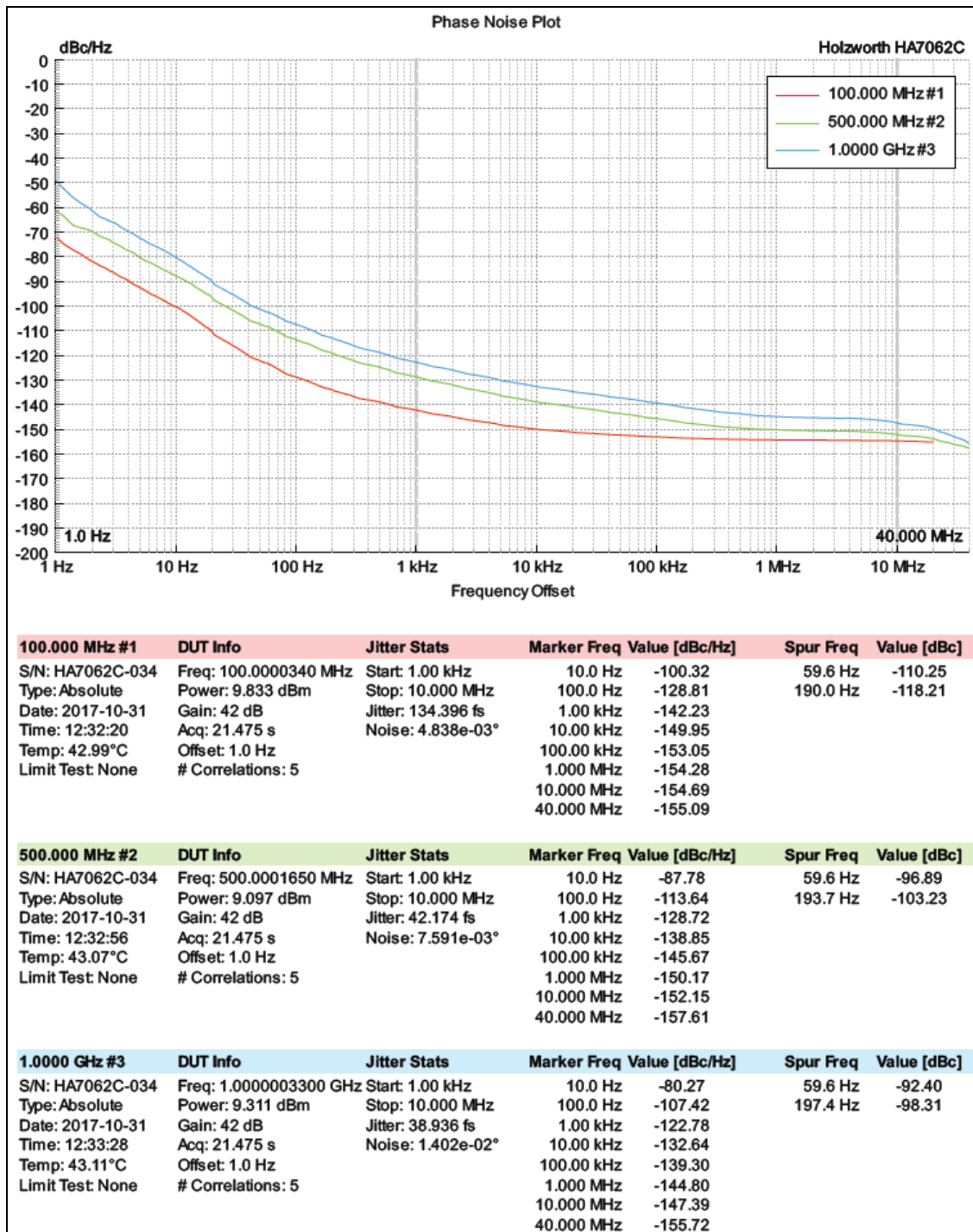

HA7063A 50GHz DOWNCONVERTER - OVERVIEW

Holzworth offers the HA7063A 50GHz Heterodyne Downconversion system to extend the HA7062C frequency range via an optimized analog architecture. The HA7062C and HA7063A are two separate chassis that operate as one test system. The two chassis connect via RF cabling at the front panels, and there is an RS-232 communications link at the rear panels for single application GUI control over the test system. Users communicate via a single Ethernet, USB, or GPIB connection. After the initial setup, there is never any need to reconfigure.



DESCRIPTION	SPECIFICATION
RF Input Connector	2.4mm (female), 50 ohm
RF Input Frequency Range PM/AM Measurements Additive Measurements Baseband Measurements	10 MHz to 50 GHz 10 MHz to 50 GHz 0.1Hz to 100 MHz
RF Input Measurement Level 10 MHz to 6 GHz >6 GHz to 18 GHz >18 GHz to 50 GHz	-30 dBm to +20 dBm -20 dBm to +20 dBm -10dBm to + 20 dBm
Offset Frequency Range PM Measurements AM Measurements Baseband Measurements	0.1Hz to 40 MHz 0.1Hz to 1 MHz 0.1Hz to 40 MHz

The full HA7063A 50GHz Downconverter specifications are available at www.holzworth.com

HX4920 FREQUENCY EXTENSION

Measurements covering >6GHz to 24GHz can easily be performed by introducing the Holzworth HX4920 Frequency Divider as shown below.

NOTE: Using a single HX4920 Downconverter in the test setup will limit the measurement floor (example: -136dBc/Hz at 10GHz) due to the additive phase noise performance of the Frequency Divider (refer to the HX4920 datasheet for more information). The additive measurement noise floor can be further improved by using a pair of HX4920 units, as shown on the following page.

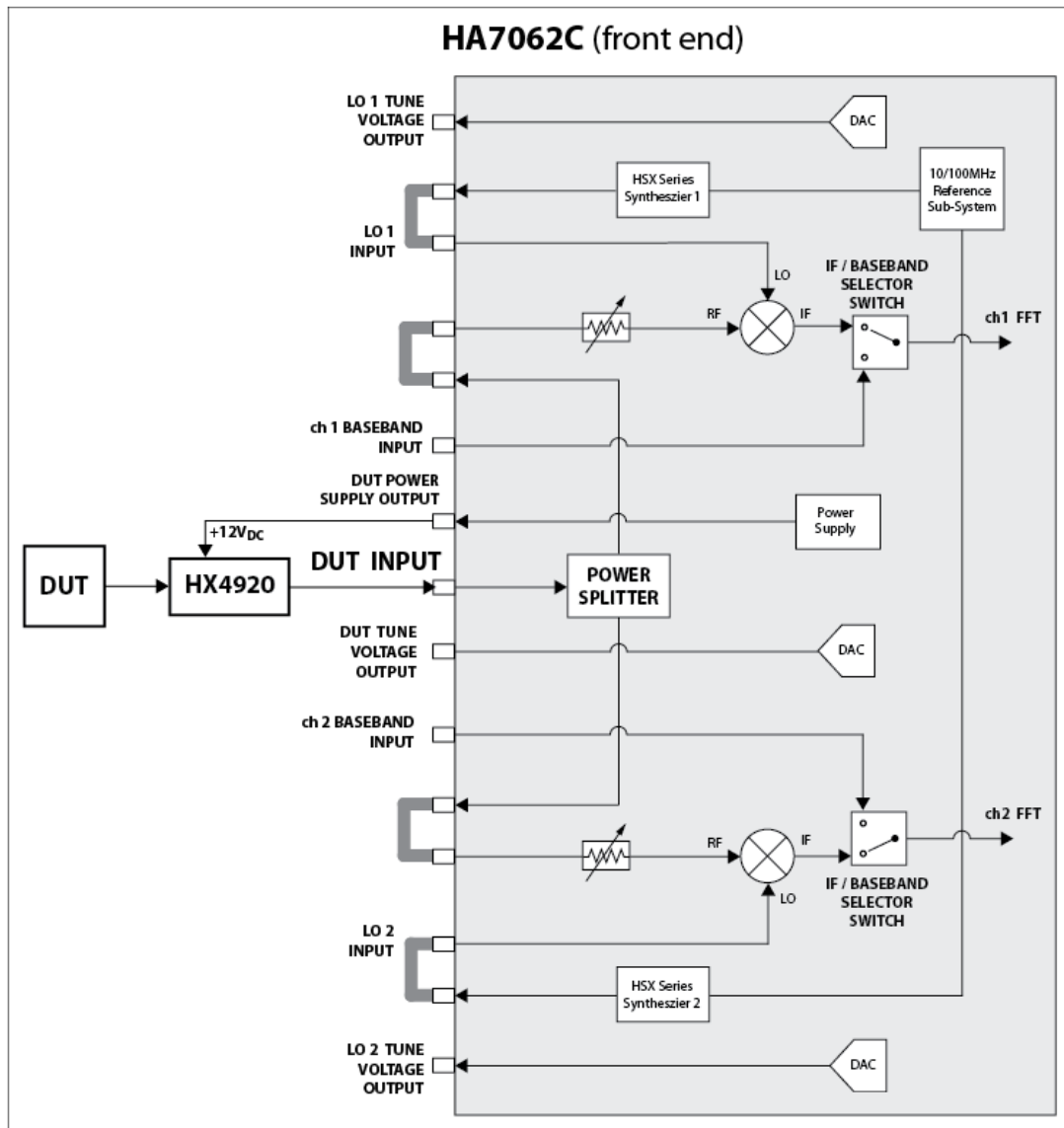

HX4920 FREQUENCY EXTENSION (continued)

For measuring higher frequency sources with performance of better than -136dBc/Hz (10GHz), a pair of HX4920 Frequency Dividers are implemented as shown below. This configuration provides a measurement noise floor of $< -153\text{dBc/Hz}$ (10GHz). Note that the HX4920 does not maintain ANSI z540.1 traceability.

Bypassing the internal power splitter as shown, allows for 2x HX4920s to be used with the analyzer. In this configuration, the downconverters are non-coherent, and their noise floor contribution is then cross-correlated out of the measurement.

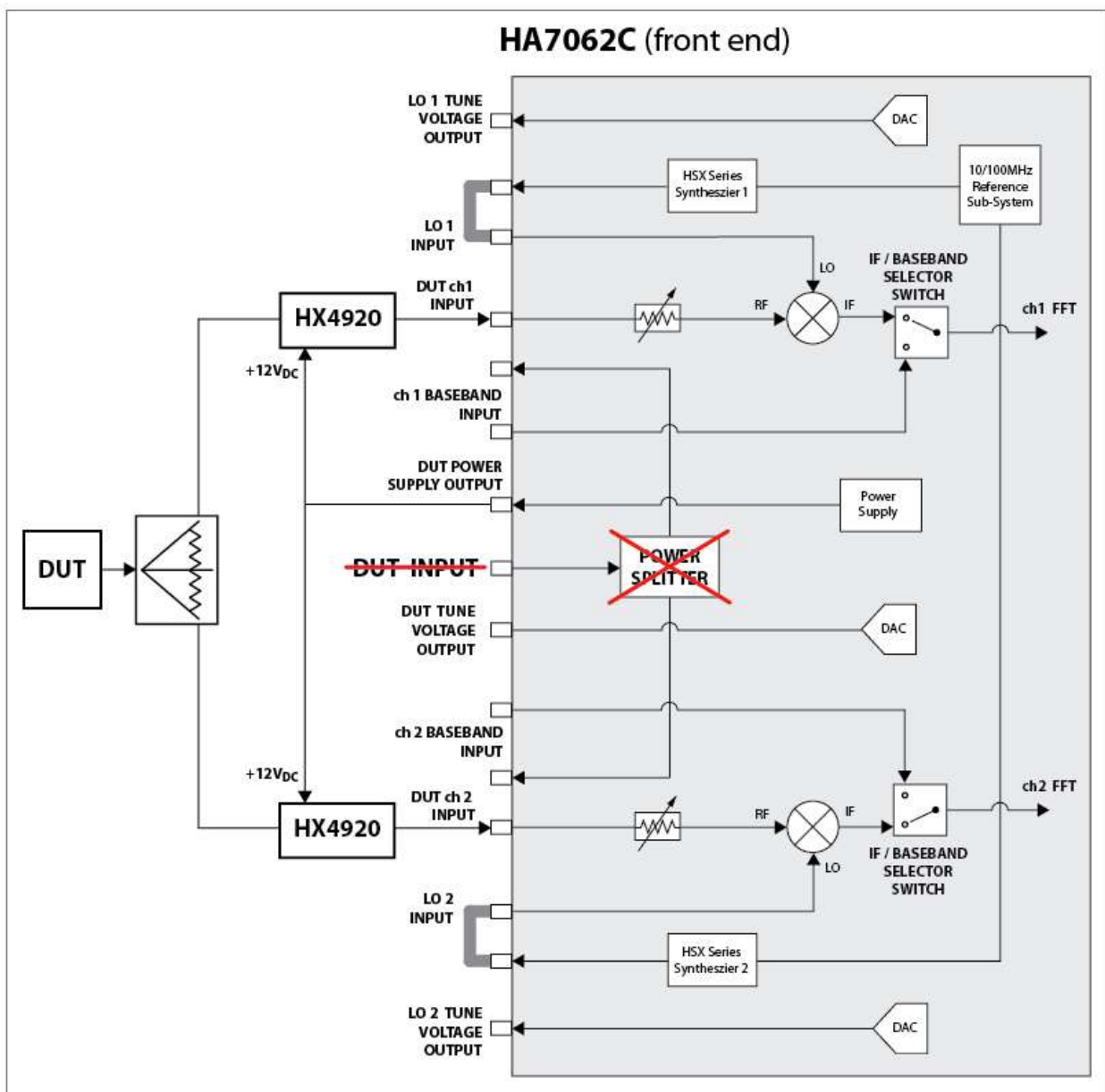

HA7062C ADDITIVE MEASUREMENT BLOCK DIAGRAMS

The architecture of the HA7062C greatly simplifies the additive measurement process. The block diagram below shows the basic configuration for an additive phase noise measurement.

A pair of Holzworth HX5100 Electronic Phase Shifters can be used in place of mechanical phase shifters to fully automate the additive measurement. The HX5100 Phase Shifters automate the process of setting quadrature between the LO and DUT inputs by using the tune voltages of LO1 and LO2 to adjust the phase offset of each signal path.

Mechanical phase shifters can also be used in place of the HX5100 Electronic Phase Shifters (recommended for DUT measurements >6GHz). The built in *Quadrature Monitor* is employed for visual feedback while adjusting mechanical phase shifters.

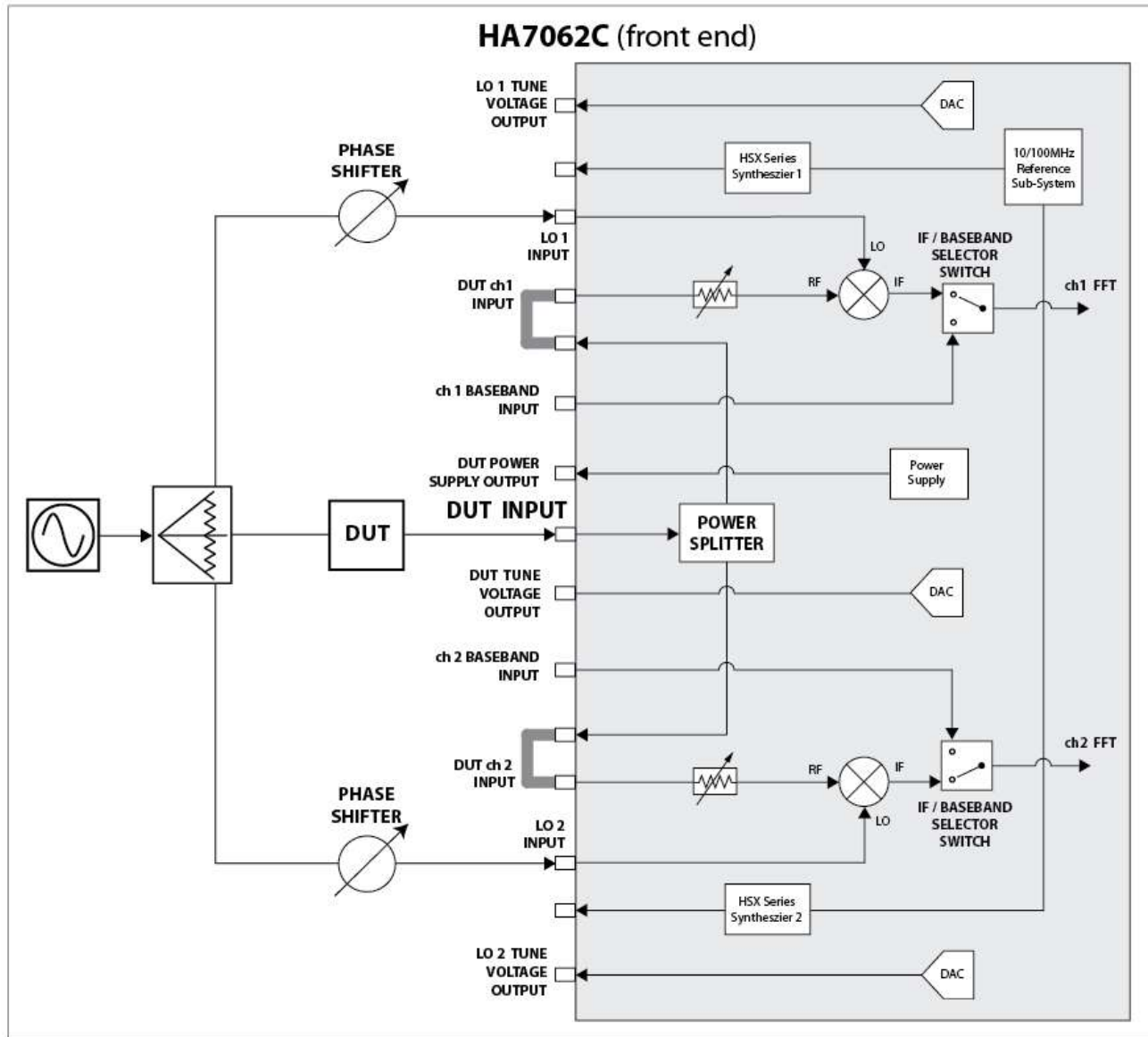

HA7062C ADDITIVE MEASUREMENT BLOCK DIAGRAMS (continued)

>6GHz ADDITIVE MEASUREMENT EXAMPLE

Additive measurements for frequencies of greater than 6GHz can be performed using 4x HX4920 Downconverters as shown below. This configuration can be used to optimize additive phase noise measurement floors with the HA7062C.

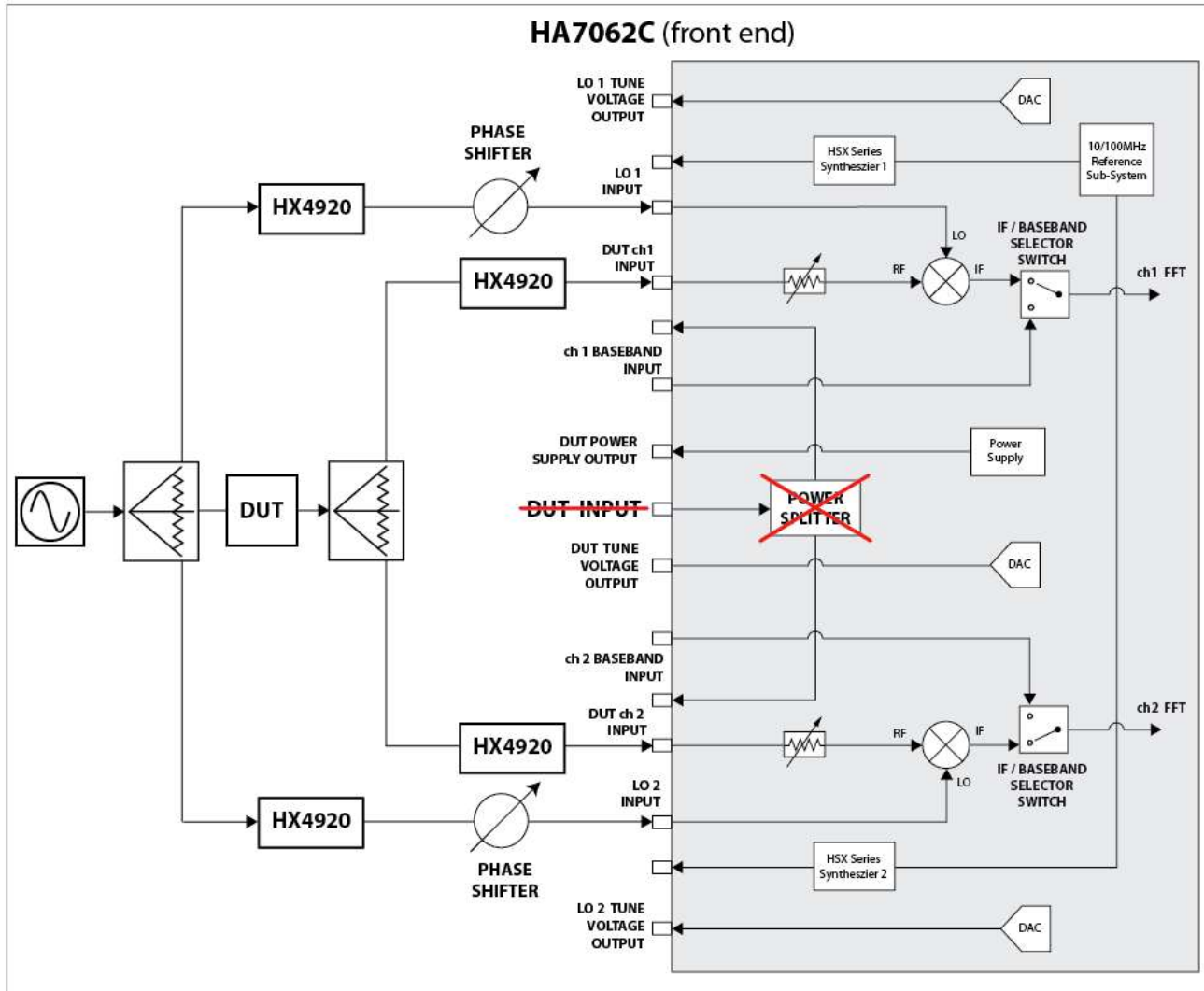

As noted on page 19, the Holzworth HA7063A 50GHz Heterodyne Downconverter is designed to manage the analog downconversion of high frequency signals. The HA7063A, paired with the HA7062C creates a fully automated test system to 50GHz for the most optimal absolute and residual (additive) measurement noise floors and fully automated operation.

The full HA7063A 50GHz Downconverter specifications are available at www.holzworth.com

HA7062C RESIDUAL MEASUREMENT BLOCK DIAGRAMS (continued)

BASEBAND ADDITIVE MEASUREMENT EXAMPLE

The baseband inputs can be utilized for measuring additive phase noise as shown in the example below. This configuration allows for the lowest noise floor measurements possible.

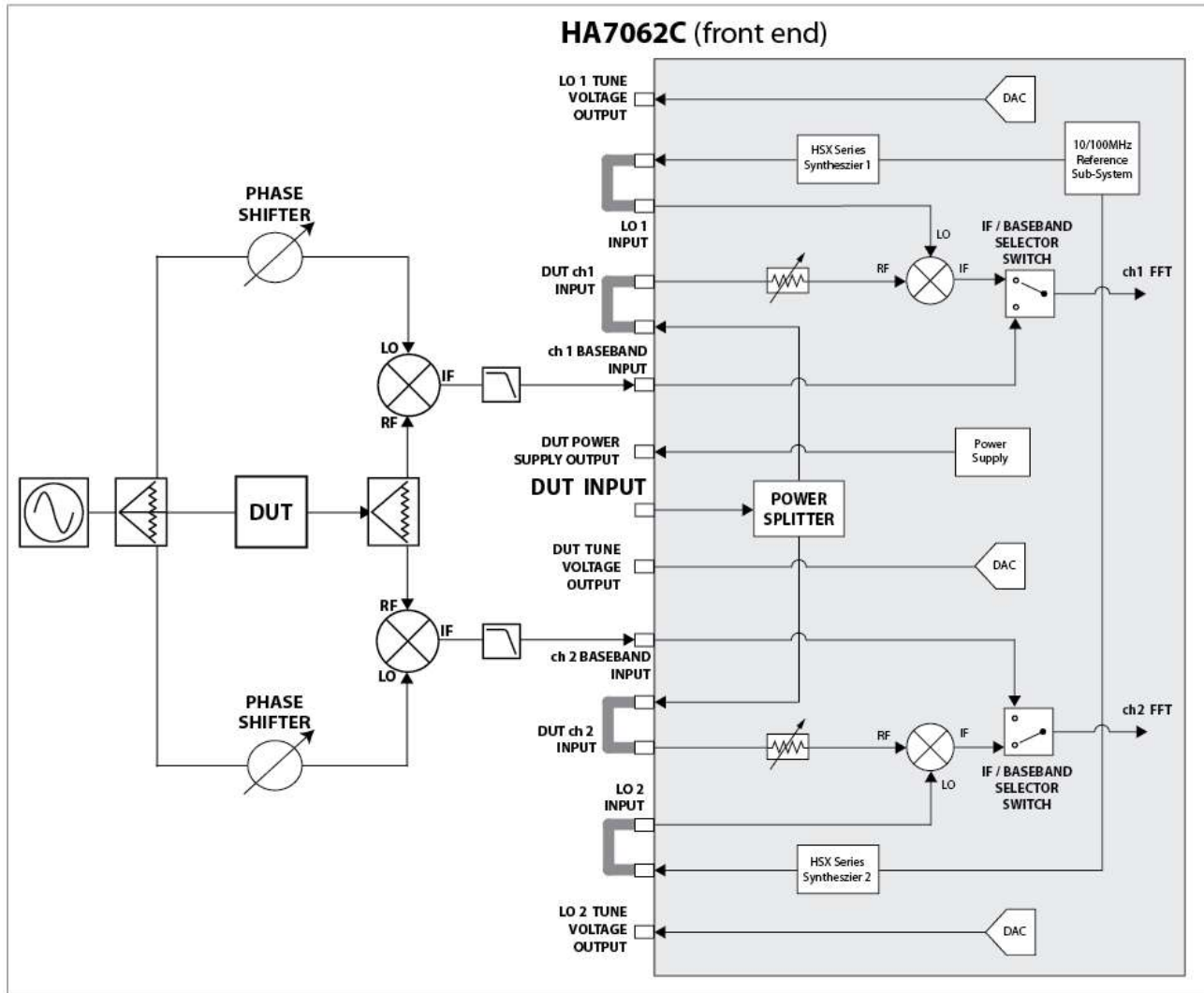

HA7062C RESIDUAL MEASUREMENT BLOCK DIAGRAMS (continued)

DDS MEASUREMENT EXAMPLE

The highly configurable front end of the HA7062C can accommodate a large number of measurement configurations. Below is a block diagram showing the HA7062C being used to measure the additive phase noise of a DDS.

NOTE: The same clock/signal source must be used to drive each DDS in this measurement.

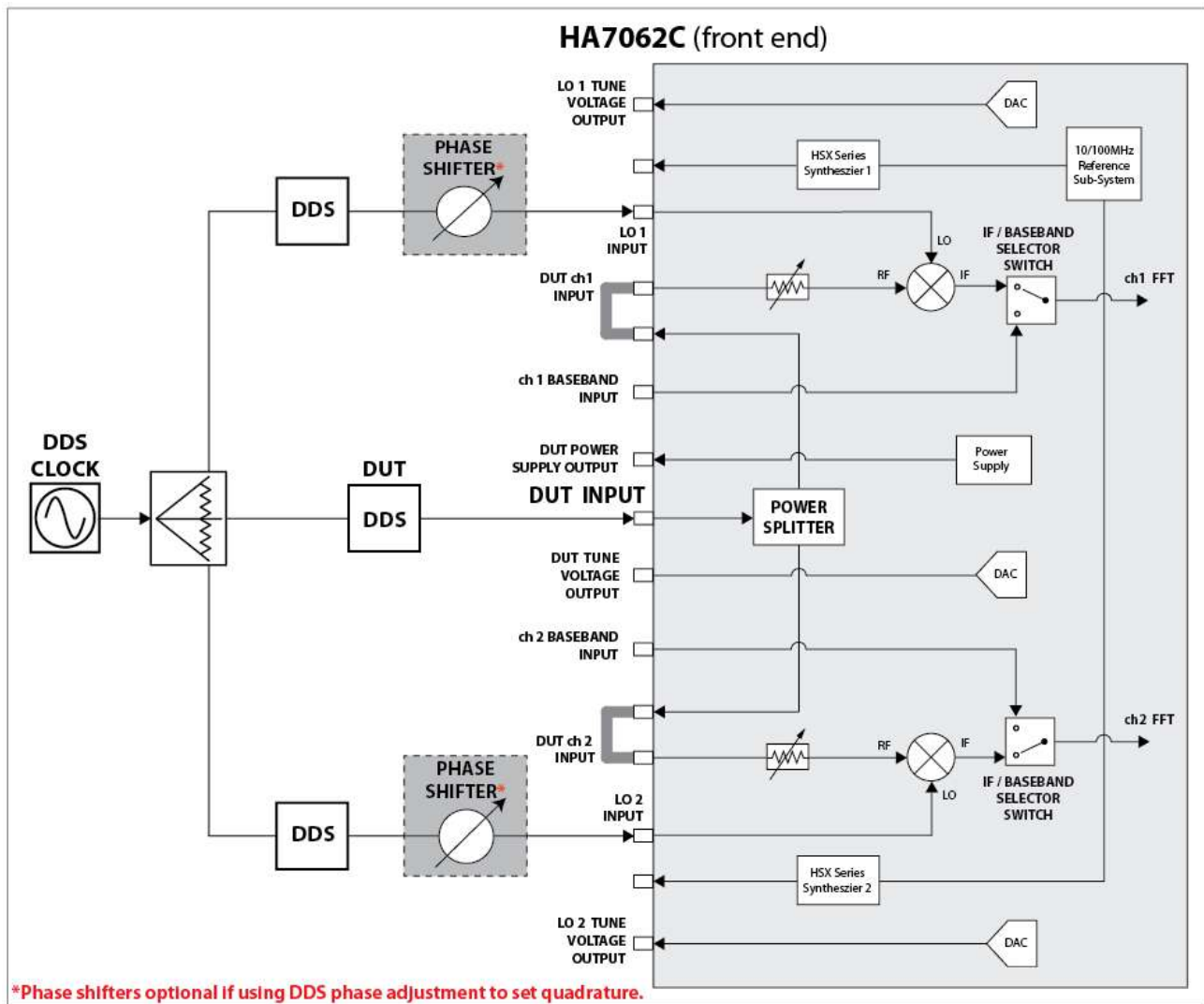



HA7062C

PHASE NOISE ANALYZER

3 YEAR WARRANTY

All Holzworth phase noise analyzer products come with a standard 3 year 100% product warranty covering manufacturing defects and workmanship. All product repairs and maintenance must be performed by Holzworth Instrumentation. Holzworth reserves the right to invalidate the warranty for any product that has been tampered with or used improperly. Refer to Holzworth Terms & Conditions of Sales for more details.

Holzworth products are proudly designed and assembled in the USA.

