

**Anritsu** Advancing beyond

**VectorStar™**

High Performance, Broadband Network Analysis Solutions

# ME7838E Series Vector Network Analyzers

Broadband VNA System

70 kHz to 110 GHz

Millimeter Waveguide VNA System

50 GHz to 1.1 THz

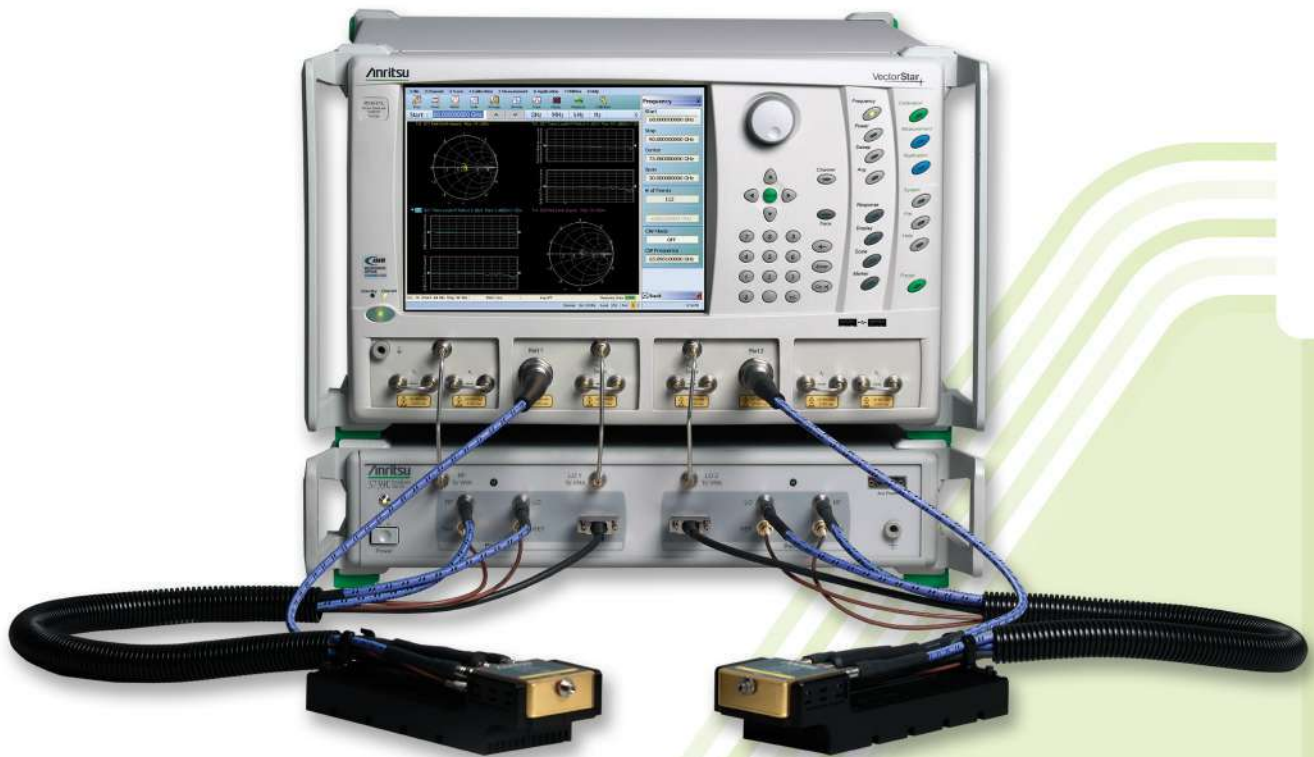

---

## ME7838E Introduction

---

### Broadband VNA System 70 kHz to 110 GHz

The ME7838E Broadband VNA System provides single sweep coverage from 70 kHz to 110 GHz. It consists of the following items:

- MS4647B VectorStar VNA, 70 kHz to 70 GHz with Option 7, Option 70, and Option 86/87 or Option 88/89
  - 3739C Broadband Millimeter-Wave Test Set and Interface Cables
  - 3743E Millimeter-Wave Modules, 2 each
- 

### Millimeter Waveguide VNA System 50 GHz to 1.1 THz

The ME7838E Millimeter-Wave configuration provides waveguide output from 50 GHz to 1.1 THz in waveguide bands. The system can extend the broadband system or be configured to operate only as a waveguide system. It consists of the following items:

- MS464xB VectorStar™ VNA, with Option 7 and Option 86/87 or Option 88/89
  - 3739C Broadband/Millimeter-Wave Test Set and Interface Cables
  - Banded Millimeter-Wave modules, 2 each
- 

### Broadband/Millimeter-Wave System Options

- MS4640B-002 – Time Domain
- MS4640B-021 – Universal Fixture Extraction
- MS464xB-031 – Dual Source Architecture
- MS464xB-032 – Internal RF Combiner
- MS4640B-035 – IF Digitizer
- MS4640B-036 – Extended IF Digitizer Memory
- MS4640B-041 – Noise Figure
- MS4640B-042 – PulseView™
- MS4640B-043 – DifferentialView™
- MS4640B-044 – IMDView™
- MS4640B-046 – Fast CW
- MS4640B-047 – Eye Diagram
- MS4640B-048 – Differential Noise Figure
- MS4640B-049 – Spectrum Analysis
- MS464xB-051 – External VNA Direct Access Loops
- MS464xB-061 – Active Measurement Suite, with 2 Attenuators
- MS464xB-062 – Active Measurement Suite, with 4 Attenuators
- 3744E-Rx – 30 to 110 GHz mmWave Receiver for Noise Figure and mmWave Antenna Measurements
- 3744E-EE – 56 to 95 GHz WR-12 Waveguide Module
- 3744E-EW – 65 to 110 GHz WR-10 Waveguide Module
- SC8215 and SC7287 – Kelvin Bias Tees

Table of Contents

ME7838E Introduction ..... 2  
 Definitions..... 3  
 Broadband Configuration ..... 5  
 Broadband Specifications..... 5  
 Broadband Measurement Examples ..... 12  
 Waveguide Band Configuration ..... 17  
 Waveguide Band Specifications ..... 18  
 Millimeter-Wave Noise Figure Measurements with Option 41/48 and 3744E-Rx ..... 23  
 Waveguide Bands from 50 GHz to 1.1 THz ..... 25  
 Standard Capabilities for All Configurations ..... 29  
 Mechanical and Environmental..... 29  
 Regulatory Compliance..... 29  
 Warranty ..... 29  
 Calibration and Correction Capabilities ..... 30  
 Mechanical Calibration/Verification Kits ..... 31  
 Test Port Cables ..... 32  
 Precision Adapters, Attenuators, and Other Components ..... 32  
 Ordering Information ..... 33

Definitions

All specifications and characteristics apply under the following conditions, unless otherwise stated:

|                                  |   |
|----------------------------------|---|
| Warm-Up Time                     | After 90 minutes of warm-up time, where the instrument is left in the ON state.   |
| Temperature Range                | Over the 25 °C ± 5 °C temperature range.  |
| Error-Corrected Specifications   | For error-corrected specifications, over 23 °C ± 3 °C, with < 1 °C variation from calibration temperature.<br>For error-corrected specifications are warranted and include guard bands, unless otherwise stated.  |
| Typical Performance              | "Typical" specifications describe expected, but not warranted, performance based on sample testing. Typical performance indicates the measured performance of an average unit and do not guarantee the performance of any individual product. "Typical" specifications do not account for measurement uncertainty and are shown in parenthesis, such as (-102 dB), or noted as Typical. |
| User Cables/Adapters             | Specifications do not include effects of any user cables, adapters, fixtures or other structures attached to the instrument.  |
| Discrete Spurious Responses      | Specifications may exclude discrete spurious responses.   |
| Internal Reference Signal        | All specifications apply with internal 10 MHz Crystal Oscillator Reference Signal.  |
| Characteristic Performance       | Characteristic performance indicates a performance designed-in and verified during the design phase. It does include guard-bands and is not covered by the product warranty.  |
| Below 300 kHz                    | All uncertainties below 300 kHz are typical.  |
| Recommended Calibration Cycle    | 12 months   |
| Interpolation Mode               | All specifications are with Interpolation Mode Off.   |
| Specifications Subject to Change | All specifications subject to change without notice. For the most current data sheet, please visit the Anritsu  |

The instrument may be protected by one or more of the following patents: 6894581, 7088111, 7545151, 7683633, 7924024, 8185078, 8306134, 8417189, 8718586, 9103873, 9606212, 9753071, 10225073, 10778592, 10225073 depending on the model and option configuration of the instrument.



**Broadband Configuration**

**ME7838E Broadband Hardware Configuration**

The ME7838E broadband VNA system provides single sweep coverage from 70 kHz to 110 GHz. It consists of the following items:

|                |   |
|----------------|---|
| VNA            | MS4647B VectorStar VNA, 70 kHz to 70 GHz with Option 7, Option 70, and Option 86/87/88/89 |
| Test Set       | 3739C Broadband Test Set and interface cables   |
| mmWave Modules | 3743E millimeter-wave Modules, 2 each   |

**ME7838E Broadband/Millimeter-Wave System Options**

The major ME7838E broadband VNA system options are:

|           |  |
|-----------|--|
| Option 2  | MS4640B-002 – Time Domain                                  |
| Option 21 | MS4640B-021 – Universal Fixture Extraction                 |
| Option 31 | MS464xB-031 – Dual Source Architecture                     |
| Option 32 | MS464xB-032 – Internal RF Combiner                         |
| Option 35 | MS4640B-035 – IF Digitizer                                 |
| Option 36 | MS4640B-036 – Extended IF Digitizer Memory                 |
| Option 41 | MS4640B-041 – Noise Figure                                 |
| Option 42 | MS4640B-042 – PulseView™                                   |
| Option 43 | MS4640B-043 – DifferentialView™                            |
| Option 44 | MS4640B-044 – IMDView™                                     |
| Option 46 | MS4640B-046 – Fast CW                                      |
| Option 47 | MS4640B-047 – Eye Diagram                                  |
| Option 48 | MS4640B-048 – Differential Noise Figure                    |
| Option 49 | MS4640B-049 – Spectrum Analysis                            |
| Option 51 | MS464xB-051 – External VNA Direct Access Loops             |
| Option 61 | MS464xB-061 – Active Measurement Suite, with 2 Attenuators |
| Option 62 | MS464xB-062 – Active Measurement Suite, with 4 Attenuators |
| Bias Tees | SC8215 and SC7287 – Kelvin Bias Tees                       |

**Broadband Specifications**

**System and Receiver Dynamic Range, Noise Floor** (Excludes localized spurious responses and crosstalk)

|                         |   |
|-------------------------|---|
| System Dynamic Range    | System dynamic range is measured as the difference between maximum port power and the RMS noise floor in a 10 Hz bandwidth and no averaging (ports terminated).   |
| Noise Floor             | Noise floor is calculated as the difference between maximum rated port power and system dynamic range.  |
| Receiver Dynamic Range  | Receiver Dynamic Range is calculated as the difference between the receiver compression level and the noise floor at Ports 1 or 2.  |
| Normalizing Measurement | Normalizing measurement made with a through line connection, with its effects compensated for. The cables between the VNA and the 3743E modules are assumed to be the part number 806-206-R, 1.85 mm cable (61 cm, 24 in long) or the part number 806-209-R, 1.85 mm cable (91.5 cm, 36 in long). All values are typical. |

| Frequency Range | System Dynamic Range (dB) <sup>a</sup> |                   | Receiver Dynamic Range (dB) <sup>a</sup> |                   | Noise Floor (dBm) <sup>a</sup> |                   |
|-----------------|--|-------------------|--|-------------------|--------------------------------|-------------------|
|                 | ME7838E                                | ME7838E Option 62 | ME7838E                                  | ME7838E Option 62 | ME7838E                        | ME7838E Option 62 |
| 70 to 300 kHz   | 93                                     | 90                | 89                                       | 86                | -83                            | -82               |
| 0.3 to 2 MHz    | 103                                    | 100               | 103                                      | 102               | -93                            | -92               |
| 2 to 10 MHz     | 115                                    | 112               | 115                                      | 114               | -105                           | -102              |
| 0.01 to 2.5 GHz | 120                                    | 116               | 121                                      | 122               | -110                           | -109              |
| 2.5 to 24 GHz   | 110                                    | 105               | 121                                      | 121               | -110                           | -108              |
| 24 to 54 GHz    | 108                                    | 105               | 124                                      | 123               | -114                           | -113              |
| 54 to 60 GHz    | 112                                    | 112               | 122                                      | 122               | -112                           | -112              |
| 60 to 65 GHz    | 108                                    | 108               | 117                                      | 117               | -107                           | -107              |
| 65 to 80 GHz    | 108                                    | 108               | 120                                      | 120               | -110                           | -110              |
| 80 to 85 GHz    | 110                                    | 110               | 123                                      | 123               | -113                           | -113              |
| 85 to 90 GHz    | 108                                    | 108               | 121                                      | 121               | -111                           | -111              |
| 90 to 95 GHz    | 111                                    | 111               | 121                                      | 121               | -111                           | -111              |
| 95 to 100 GHz   | 107                                    | 107               | 117                                      | 117               | -107                           | -107              |
| 100 to 110 GHz  | 109                                    | 109               | 122                                      | 122               | -112                           | -112              |

a. Excludes localized spurious responses and crosstalk.

**Test Port Power, Receiver Compression<sup>a</sup>**

Port power control is provided by the base VNA for frequencies below 54 GHz, and by the 3743E mmWave module for frequencies greater than 54 GHz. Receiver compression point is defined as the port power level beyond which the response may be compressed more than 0.2 dB relative to normalization level. 10 Hz IF bandwidth used to remove trace noise effects. All typical.

| Frequency Range | Port Power        |  | Receiver Compression |                               |
|-----------------|-------------------|--|----------------------|-------------------------------|
|                 | Max Power ME7838E | Max Power ME7838E Option 62 <sup>b</sup> | Compression ME7838E  | Compression ME7838E Option 62 |
| 70 to 300 kHz   | 10                | 8  | 6                    | 6                             |
| 0.3 to 2 MHz    | 10                | 8  | 10                   | 12                            |
| 2 to 10 MHz     | 10                | 10                                       | 10                   | 12                            |
| 0.01 to 2.5 GHz | 10                | 7  | 11                   | 13                            |
| 2.5 to 24 GHz   | 0                 | -3                                       | 11                   | 13                            |
| 24 to 54 GHz    | -6                | -8                                       | 10                   | 10                            |
| 54 to 60 GHz    | 0                 | 0  | 10                   | 10                            |
| 60 to 65 GHz    | 1                 | 1  | 10                   | 10                            |
| 65 to 80 GHz    | -2                | -2                                       | 10                   | 10                            |
| 80 to 85 GHz    | -3                | -3                                       | 10                   | 10                            |
| 85 to 90 GHz    | -3                | -3                                       | 10                   | 10                            |
| 90 to 95 GHz    | 0                 | 0  | 10                   | 10                            |
| 95 to 100 GHz   | 0                 | 0  | 10                   | 10                            |
| 100 to 110 GHz  | -3                | -3                                       | 10                   | 10                            |

a. Using the 806-206-R, 1.85 mm (61 cm, 24 in long) test port cables between the VNA and the 3743E mmWave modules.

b. Use this column also for Options 51 and 61 although the performance between 10 MHz and 54 GHz will characteristically be better by 1 dB or more for Option 51, and will characteristically be better by 1 dB or more for Option 61 (with port 1 driving and port 2 receiving).

**Power Range, Accuracy, Linearity, and Resolution**

Accuracy is defined at -10 dBm or max rated power, whichever is lower. Linearity is defined as the incremental error between the accuracy test power level and 5 dB below. Typical.

| Frequency Range | Range (dB) |                   | Accuracy (dB) | Linearity (dB) | Resolution (dB) |
|-----------------|------------|-------------------|---------------|----------------|-----------------|
|                 | ME7838E    | ME7838E Option 62 |               |                |                 |
| 70 to 300 kHz   | +10 to -25 | +8 to -85         | ±1.5          | ±1.5           | 0.01            |
| 0.3 to 2 MHz    | +10 to -25 | +8 to -85         | ±1.5          | ±1.5           | 0.01            |
| 2 to 10 MHz     | +10 to -25 | +10 to -85        | ±1.5          | ±1.5           | 0.01            |
| .01 to 2.5 GHz  | +10 to -25 | +8 to -85         | ±1.0          | ±1.0           | 0.01            |
| 2.5 to 24 GHz   | 0 to -25   | -3 to -85         | ±1.0          | ±1.0           | 0.01            |
| 24 to 54 GHz    | -6 to -30  | -8 to -90         | ±1.5          | ±1.0           | 0.01            |
| 54 to 60 GHz    | 0 to -55   | 0 to -55          | ±2.0          | ±1.5           | 0.01            |
| 60 to 65 GHz    | +1 to -55  | +1 to -55         | ±2.0          | ±1.5           | 0.01            |
| 65 to 80 GHz    | -2 to -55  | -2 to -55         | ±2.0          | ±1.5           | 0.01            |
| 80 to 85 GHz    | -3 to -55  | -3 to -55         | ±2.0          | ±1.5           | 0.01            |
| 85 to 90 GHz    | -3 to -55  | -3 to -55         | ±2.0          | ±1.5           | 0.01            |
| 90 to 95 GHz    | 0 to -55   | 0 to -55          | ±2.0          | ±1.5           | 0.01            |
| 95 to 100 GHz   | 0 to -55   | 0 to -55          | ±3.0          | ±2.0           | 0.01            |
| 100 to 110 GHz  | -3 to -50  | -3 to -55         | ±3.0          | ±2.0           | 0.01            |

**High Level Noise**

Noise measured at 1 kHz IF bandwidth, at maximum power or compression limit (whichever is less), with through transmission. RMS. Typical.

| Frequency (GHz) | Magnitude (dB) | Phase (deg.) |
|-----------------|----------------|--------------|
| 70 to 300 kHz   | < 0.04         | < 0.4        |
| 0.3 to 2 MHz    | < 0.005        | < 0.05       |
| 2 to 10 MHz     | < 0.005        | < 0.05       |
| 0.01 to 2.5     | < 0.005        | < 0.05       |
| 2.5 to 24       | < 0.006        | < 0.06       |
| 24 to 54        | < 0.005        | < 0.06       |
| 54 to 80        | < 0.005        | < 0.06       |
| 80 to 110       | < 0.008        | < 0.09       |

**Stability**

Ratioed measurement at maximum leveled power and with nominally a full coaxial reflect or a stable coaxial thru over the normal specified temperature range. Typical.

| Frequency (GHz) | Magnitude (dB/°C) | Phase (deg./°C) |
|-----------------|-------------------|-----------------|
| 70 to 300 kHz   | < 0.015           | < 0.1           |
| 0.3 to 2 MHz    | < 0.015           | < 0.05          |
| 2 to 10 MHz     | < 0.01            | < 0.05          |
| 0.01 to 2.5     | < 0.01            | < 0.05          |
| 2.5 to 30       | < 0.01            | < 0.09          |
| 30 to 54        | < 0.01            | < 0.07          |
| 54 to 80        | < 0.015           | < 0.1           |
| 80 to 110       | < 0.015           | < 0.15          |

**Frequency Resolution, Accuracy, and Stability**

| Resolution | Accuracy   | Stability   |
|------------|--|---|
| 1 Hz       | $\pm 5 \times 10^{-7}$ Hz/Hz<br>(at time of calibration) | < $5 \times 10^{-9}$ /°C over 0 °C to 50 °C temperature<br>< $1 \times 10^{-9}$ /day aging, instrument on |

**Uncorrected (Raw) Port Characteristics**

Typical performance with either ME7838E or ME7838E with Option 62.

| Frequency (GHz) | Directivity (dB) | Port Match (dB) |
|-----------------|------------------|-----------------|
| <10 MHz         | 10 <sup>a</sup>  | 8               |
| 0.01 to 2.5     | 9 <sup>a</sup>   | 10              |
| 2.5 to 30       | 5 <sup>a</sup>   | 12              |
| 30 to 40        | 5 <sup>a</sup>   | 5               |
| 40 to 54        | 10               | 5               |
| 54 to 80        | 10               | 10              |
| 80 to 110       | 5                | 7               |

a. Raw directivity is degraded below 300 kHz, 2.2 to 2.5 GHz and in narrow bands within 10 to 34 GHz.

**Corrected System Performance and Uncertainties - SOLT/SSST**

With 12-term broadband calibration (concatenated SOLT and Triple Offset Short Calibration (SSST)), using the 3656B W1 Calibration Kit and .cfc component definitions. Cable flexure and drift effects are not included. Typical.

| Frequency (GHz) | Directivity (dB) | Source Match (dB) | Load Match (dB) | Reflection Tracking (dB) | Transmission Tracking (dB) |
|-----------------|------------------|-------------------|-----------------|--------------------------|----------------------------|
| 70 to 10MHz     | 36               | 36                | 36              | ± 0.1                    | ± 0.1                      |
| 0.01 to 2.5     | 40               | 41                | 40              | ± 0.05                   | ± 0.05                     |
| 2.5 to 20       | 40               | 41                | 40              | ± 0.05                   | ± 0.05                     |
| 20 to 67        | 38               | 41                | 36              | ± 0.05                   | ± 0.07                     |
| 67 to 95        | 37               | 40                | 35              | ± 0.05                   | ± 0.07                     |
| 95 to 110       | 35               | 35                | 33              | ± 0.05                   | ± 0.07                     |

**Measurement Uncertainties - SOLT/SSST**

The graphs give measurement uncertainties after the above calibration. The errors are worst case contribution of residual directivity, load and source match, frequency response and isolation, network analyzer dynamic accuracy, and connector repeatability while noise effects are added on an RSS basis. 10 Hz IF Bandwidth is used. For transmission uncertainties, it is assumed that  $S_{11} = S_{22} = 0$ . For reflection uncertainties, it is assumed that  $S_{21} = S_{12} = 0$ . For other conditions, please use our free Exact Uncertainty calculator software, downloadable from the Anritsu web site at [www.anritsu.com](http://www.anritsu.com).

Reflection Magnitude Uncertainty (95%)  
ME7838E with 3656B W1 Cal Kit using concatenated SOLT/SSST

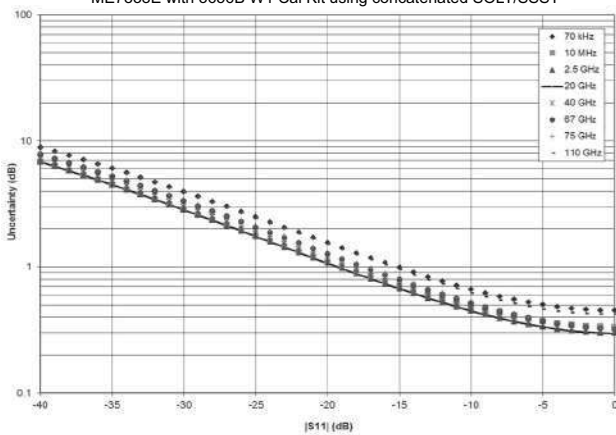

Reflection Phase Uncertainty (95%)  
ME7838E with 3656B W1 Cal Kit using concatenated SOLT/SSST

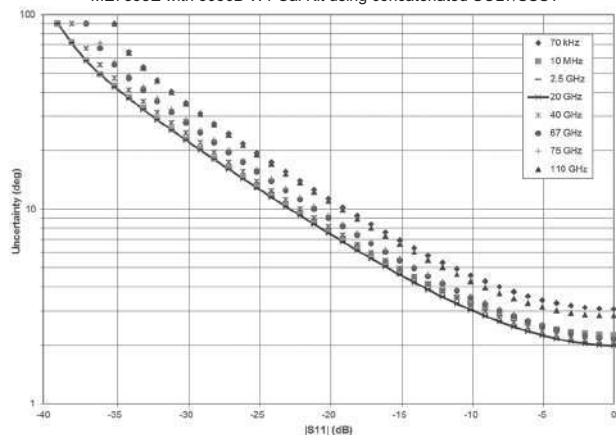

Transmission Magnitude Uncertainty (95%)  
ME7838E with 3656B W1 Cal Kit using concatenated SOLT/SSST

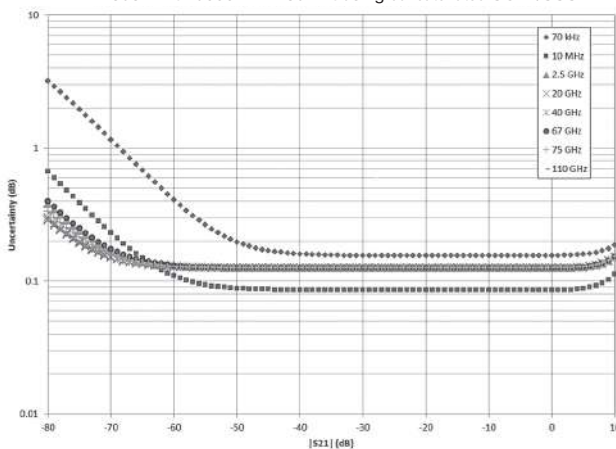

Transmission Phase Uncertainty (95%)  
ME7838E with 3656B W1 Cal Kit using concatenated SOLT/SSST

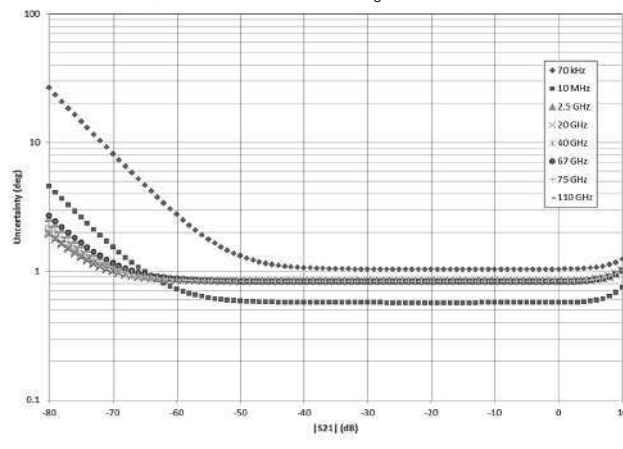

**Corrected System Performance and Uncertainties – SOLT/SSST with .s1p Standards Definitions**

With 12-term broadband calibration (concatenated SOLT and Triple Offset Short Calibration (SSST)), using the 3656B-3 W1 Calibration Kit and .s1p component definitions. Cable flexure and drift effects are not included. Typical values are in parentheses.

| Frequency (GHz) | Directivity (dB) | Source Match (dB) | Load Match (dB) | Reflection Tracking (dB) | Transmission Tracking (dB) |
|-----------------|------------------|-------------------|-----------------|--------------------------|----------------------------|
| 70 to 10MHz     | 43 (50)          | 43 (50)           | 40 (43)         | ± 0.1                    | ± 0.1                      |
| 0.01 to 2.5     | 43 (50)          | 43 (50)           | 40 (43)         | ± 0.05                   | ± 0.05                     |
| 2.5 to 20       | 43 (50)          | 42 (50)           | 40 (43)         | ± 0.05                   | ± 0.05                     |
| 20 to 67        | 38 (44)          | 40 (44)           | 36 (42)         | ± 0.05                   | ± 0.07                     |
| 67 to 90        | 33 (38)          | 40 (44)           | 30 (36)         | ± 0.05                   | ± 0.07                     |
| 90 to 110       | 34 (38)          | 40 (43)           | 32 (36)         | ± 0.05                   | ± 0.07                     |

**Measurement Uncertainties – SOLT/SSST with .s1p Standards Definitions**

The graphs give measurement uncertainties after the above calibration. The errors are worst case contribution of residual directivity, load and source match, frequency response and isolation, network analyzer dynamic accuracy, and connector repeatability while noise effects are added on an RSS basis. 10 Hz IF Bandwidth is used. For transmission uncertainties, it is assumed that  $S_{11} = S_{22} = 0$ . For reflection uncertainties, it is assumed that  $S_{21} = S_{12} = 0$ . For other conditions, please use our free Exact Uncertainty calculator software, downloadable from the Anritsu web site at [www.anritsu.com](http://www.anritsu.com).

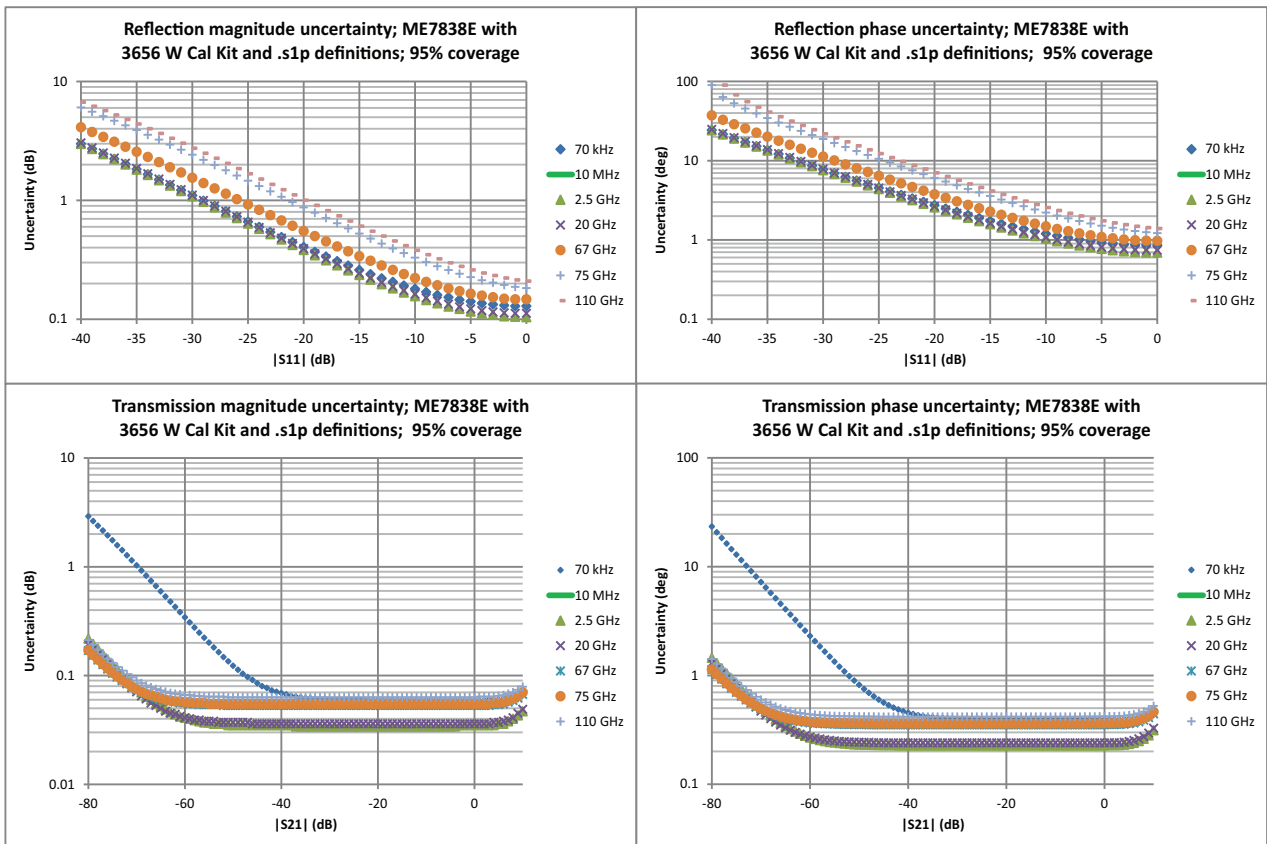

**Corrected System Performance and Uncertainties - LRL/LRM**

With 12 term LRL/LRM calibration using on-wafer substrate standards. Typical. Based on a typical vendor supplied impedance standard substrate.

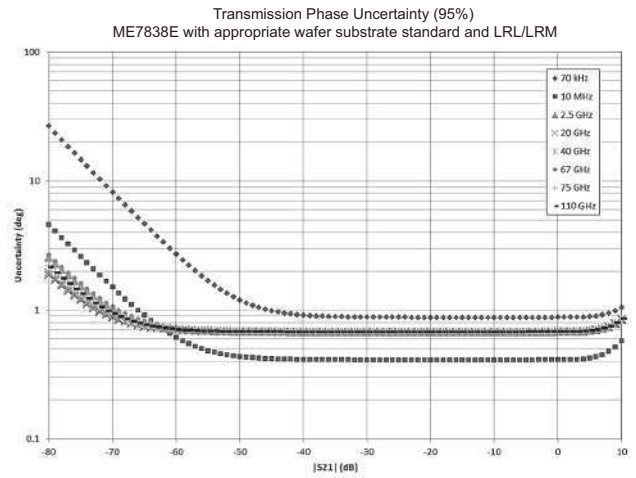
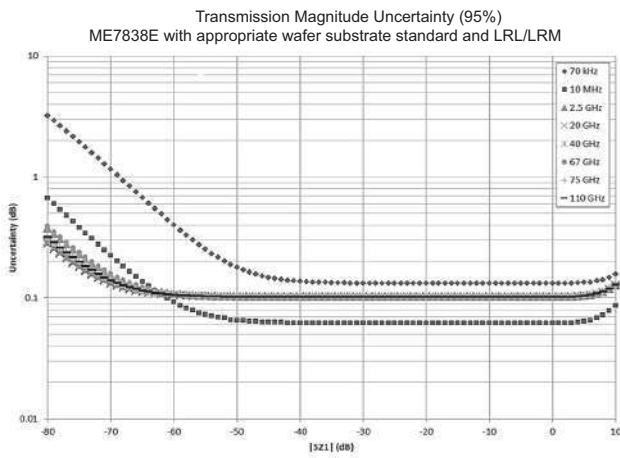
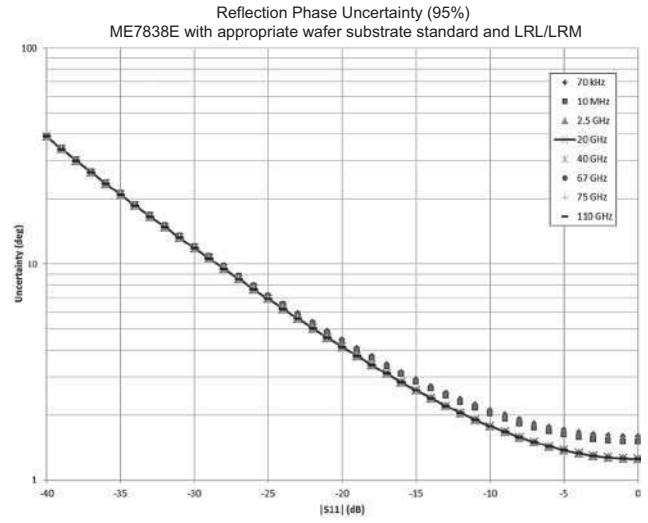
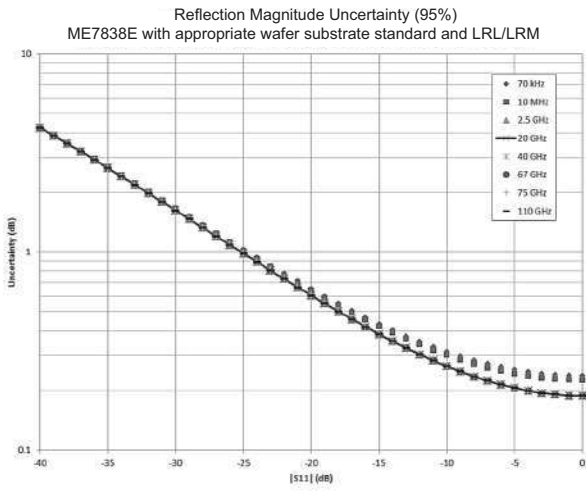

**Measurement Time**

Measurement times include sweep time, retrace time, and band-switching time. Typical.

**Measurement Time (ms)**

Full Band, 70 kHz to 110 GHz, Display ON, and ALC ON.

| Calibration        | IFBW   | Measurement Time (ms) <sup>a</sup> |              |               |               |
|--------------------|--------|------------------------------------|--------------|---------------|---------------|
|                    |        | 401 Points                         | 1,601 Points | 10,001 Points | 25,000 Points |
| 1-port calibration | 1 MHz  | 80                                 | 100          | 350           | 700           |
|                    | 30 kHz | 90                                 | 160          | 600           | 1500          |
|                    | 10 kHz | 110                                | 240          | 1100          | 2600          |
|                    | 1 kHz  | 470                                | 1600         | 10,000        | 25,000        |
|                    | 10 Hz  | 47,000                             | 160,000      | 1,000,000     | 2,500,000     |
| 2-port calibration | 1 MHz  | 160                                | 200          | 700           | 1400          |
|                    | 30 kHz | 180                                | 320          | 1200          | 3000          |
|                    | 10 kHz | 220                                | 480          | 2200          | 5200          |
|                    | 1 kHz  | 940                                | 3200         | 20,000        | 50,000        |
|                    | 10 Hz  | 94,000                             | 320,000      | 2,000,000     | 5,000,000     |

a. Measurement times are for the ME7838E Broadband VNA System

**Measurement Time (ms) vs. System Dynamic Range (dB)**

Full Band, Display ON, and ALC ON.

| Calibration                       | 401 Points Measurement Time | Achieved System Dynamic Range (Opt 062 at 54 GHz) | IFBW and Averaging Used |
|-----------------------------------|-----------------------------|---|-------------------------|
| Uncorrected or 1-port calibration | 110                         | 77  | 10 kHz/no avg           |
|                                   | 470                         | 87  | 1 kHz/no avg            |
| 2-port calibration                | 220                         | 77  | 10 kHz/no avg           |
|                                   | 940                         | 87  | 1 kHz/no avg            |

**Block Diagram – ME7838E Broadband VNA System**

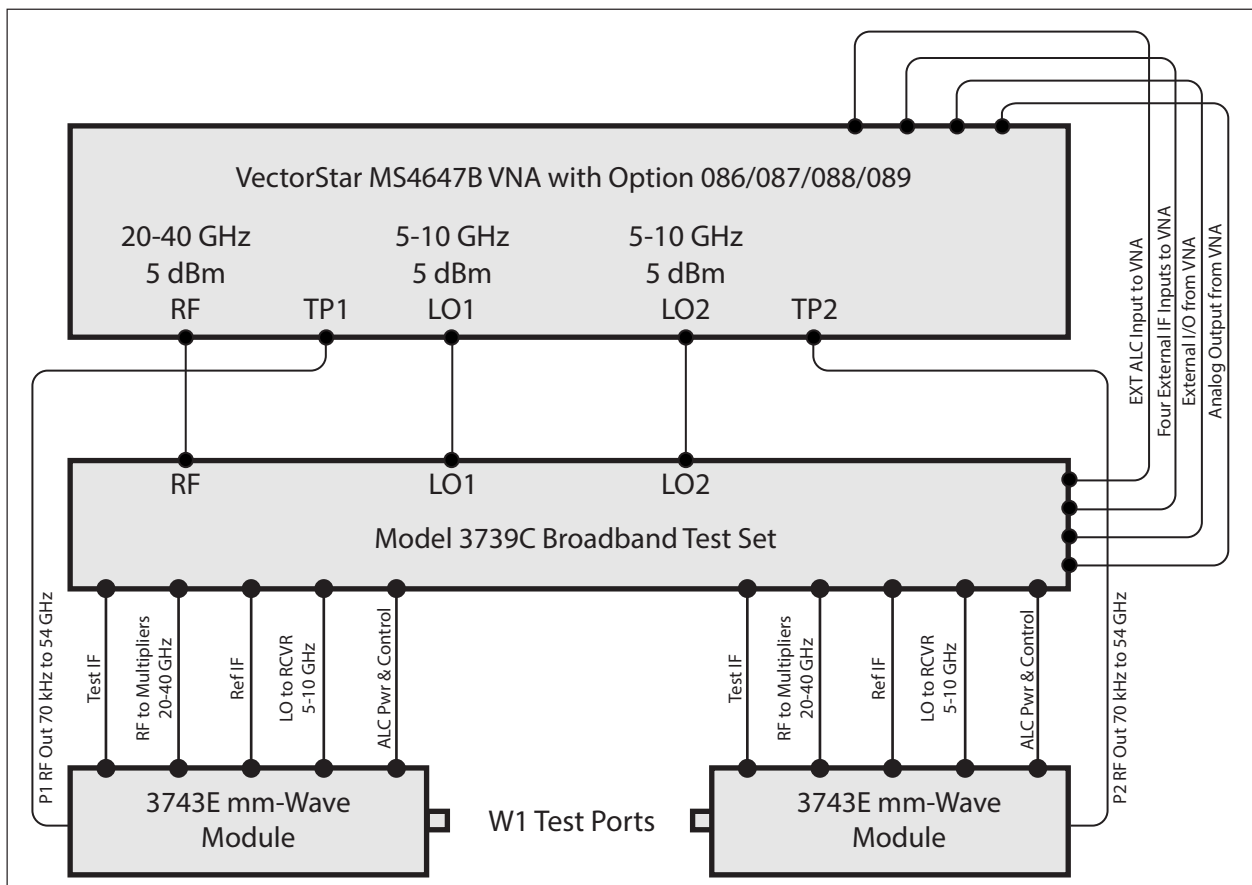

Broadband Configuration Block Diagram

**SC8215 and SC7287 Kelvin Bias Tees**

Provides Sense and Force SMC connections close to the mmWave module to minimize the IR drops associated with the impedances between the bias tee and the DUT.

| Part Number          | Description  | Voltage             | Current             |
|----------------------|--|---------------------|---------------------|
| SC8215               | The SC8215 is a V-connectorized bias tee usable with the mmWave modules in the ME7838E for system frequencies of 70 kHz to 110 GHz. Stand-alone, it is usable to 70 GHz.   | Max Voltage: 16 VDC | Max Current: 100 mA |
| SC7287               | The SC7287 is a V-connectorized bias tee usable with the mmWave modules in the ME7838E for system frequencies of 100 MHz to 110 GHz. Stand-alone, it is usable to 70 GHz.  | Max Voltage: 50 VDC | Max Current: 500 mA |
| Tri-Axial Output SMU | For applications requiring Source Measure Units (SMU) with tri-axial outputs, a tri-axial (male) to SMC (male) cable is available, with the inner-shield isolated from ground at the bias tee SMC end, to float at the SMU guard potential. Check the accessories list for ordering information <a href="#">on page 37</a> . |                     |                     |

**Broadband Measurement Examples**

The following figures are measurement examples of typical ME7838E Broadband system performance.

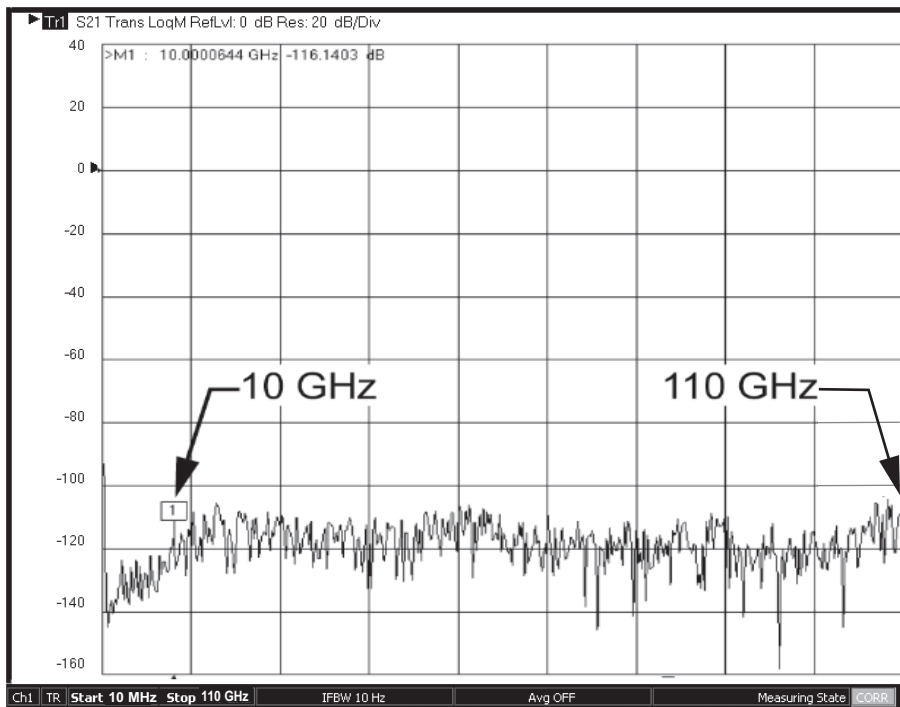

Typical dynamic range of ME7838E system at the W1 1 mm coaxial test port from 70 kHz to 110 GHz.

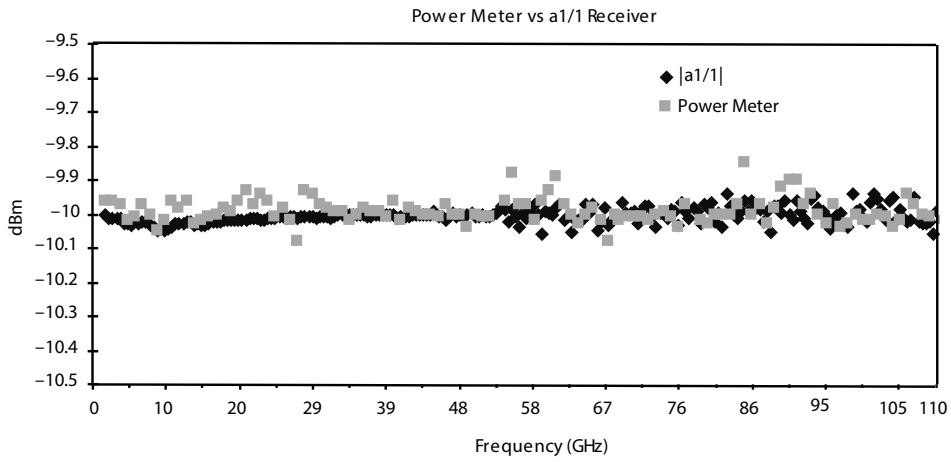

An example of typical power measurement agreement: power sensor vs. ME7838E a1 reference receiver.

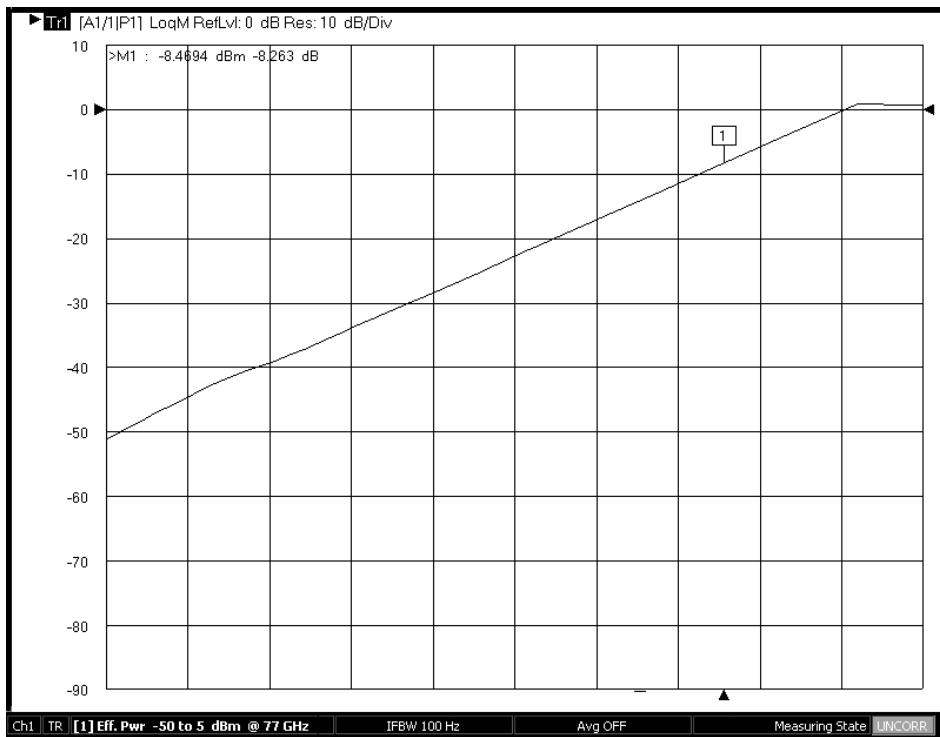

Typical power sweep range at 77 GHz. By using detection and power control inside the 3743E millimeter-wave module; improved accuracy, linearity and range can be achieved.

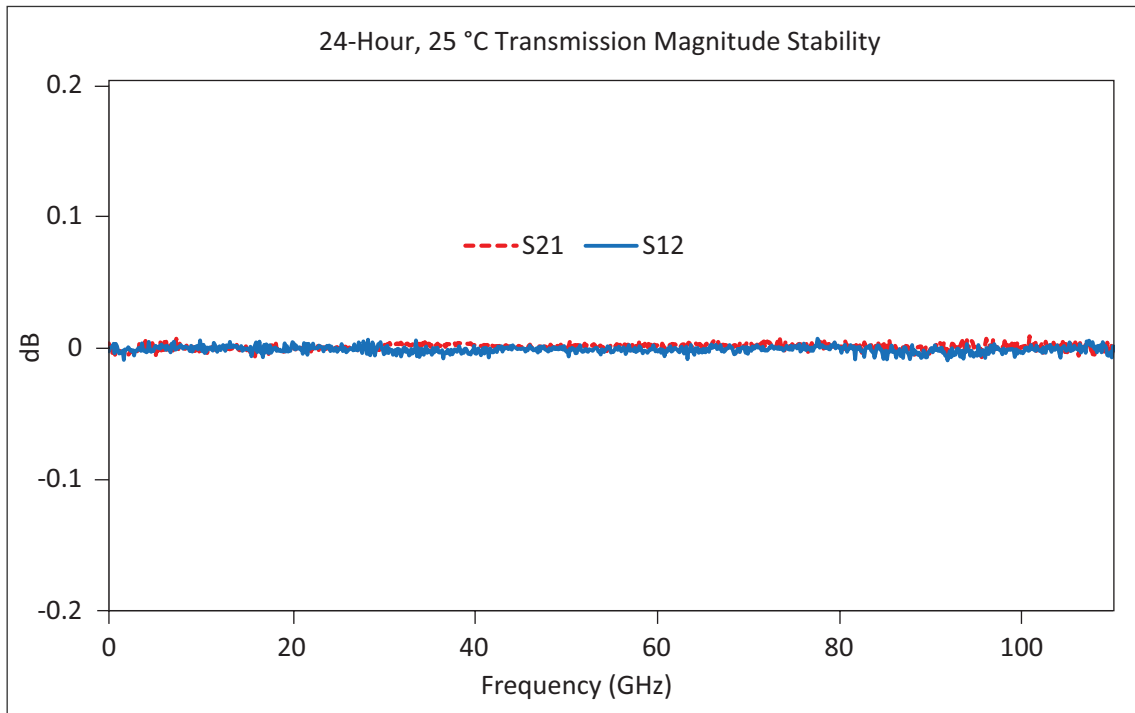

Typical 24-Hour Transmission Magnitude Stability

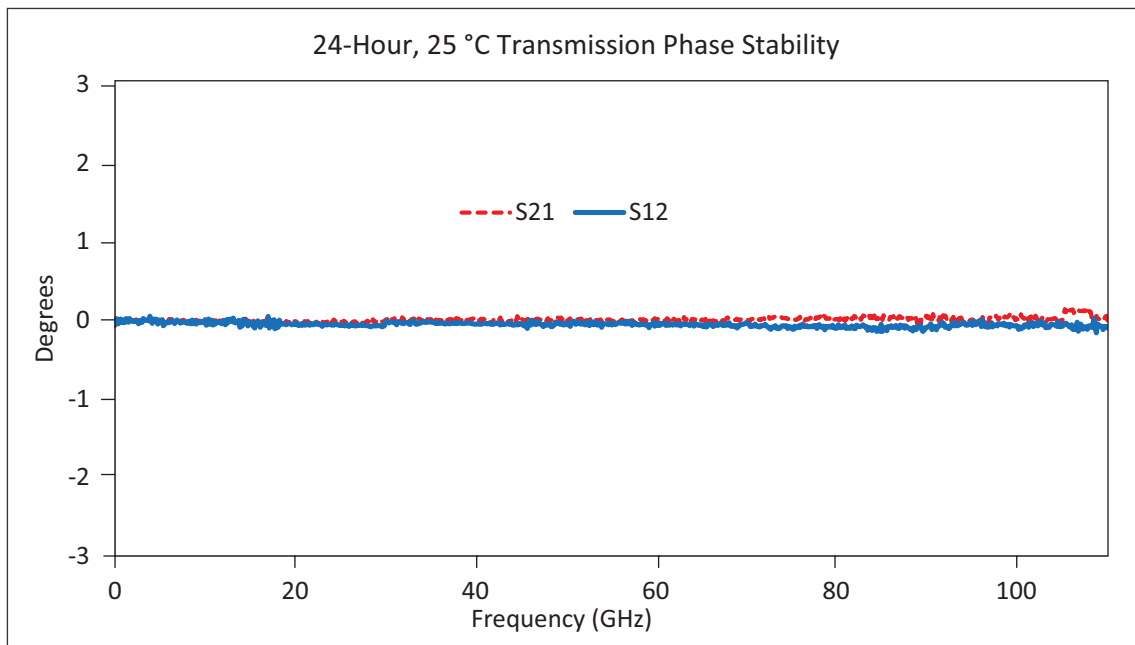

Typical 24-Hour Transmission Phase Stability

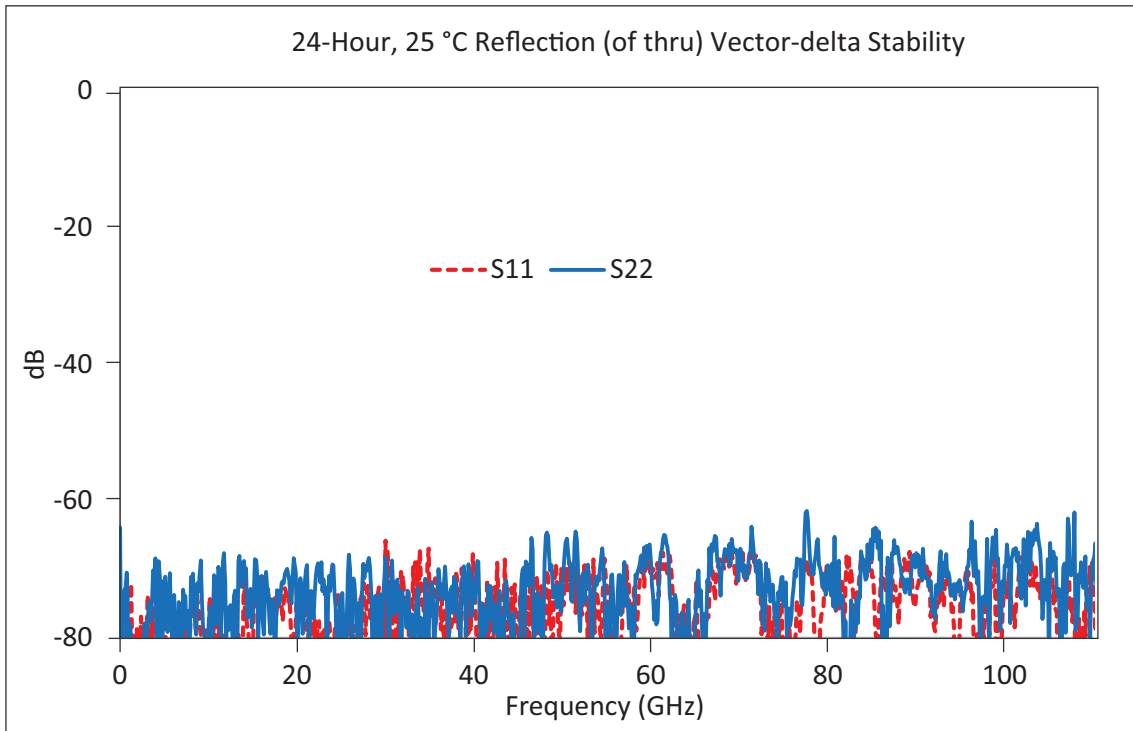

Typical 24-Hour Thru Line Match Vector-delta Stability

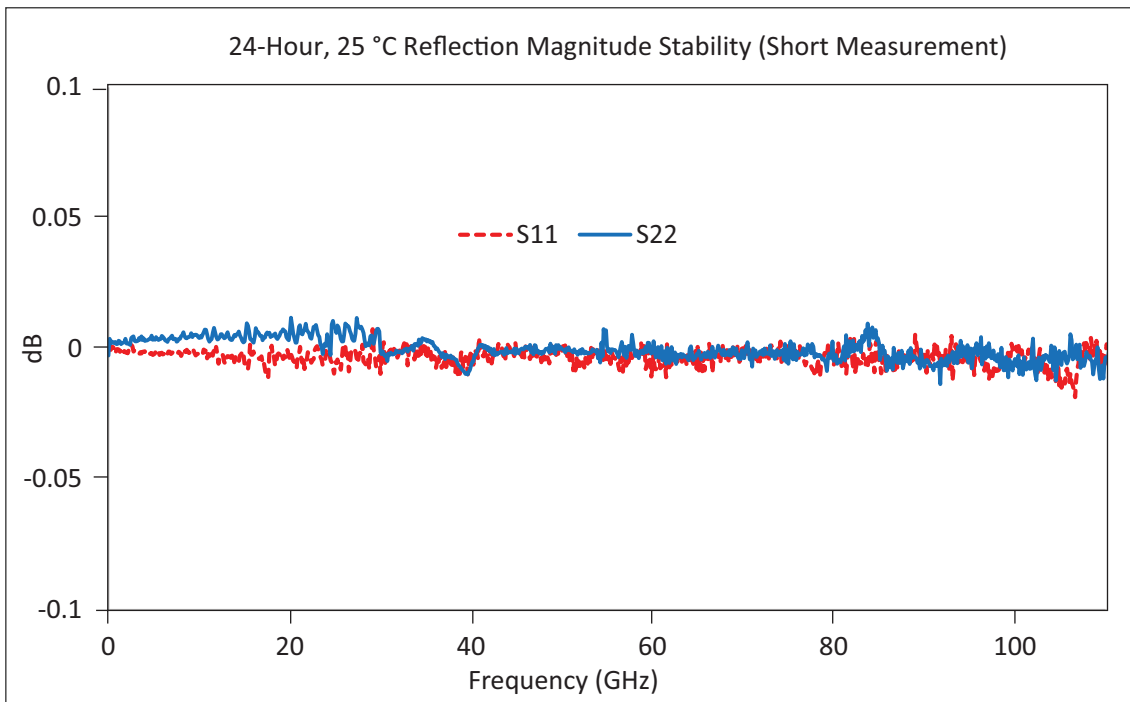

Typical 24-Hour Reflection Magnitude Stability

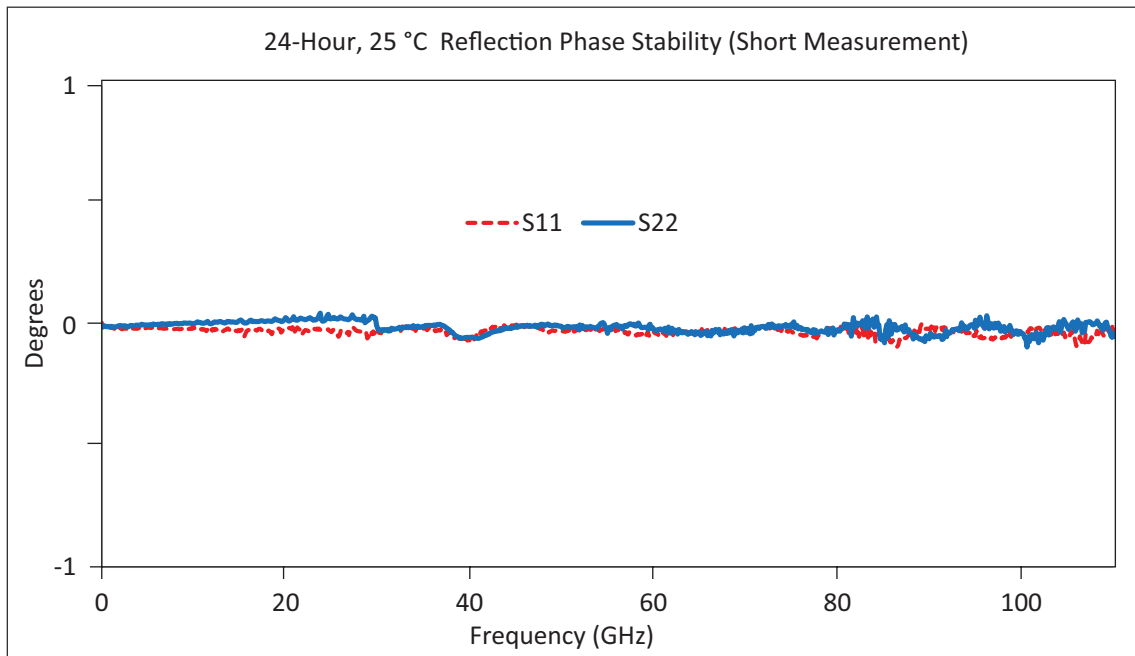

Typical 24-Hour Reflection Phase Stability

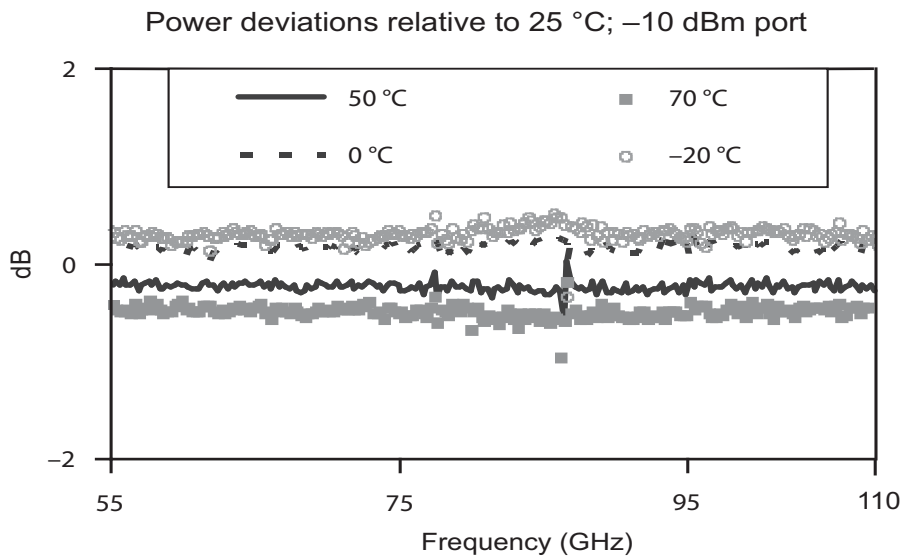

Typical power deviation with respect to wide temperature variation

## Waveguide Band Configuration

### ME7838E Millimeter-Wave VNA, Waveguide Bands

Three configurations are available for waveguide band operation for E and W bands when using the ME7838E system.

- 3743E Module First, the Anritsu 3743E Broadband millimeter-wave (mmWave) module can be adapted to waveguide measurements using waveguide adapters.
- mmWave Modules Second, the Anritsu 3744E-EE or 3744E-EW millimeter-wave module can be used. These version modules operate in the extended E and W waveguide bands and are operational using the MS4644B, or MS4647B VectorStar (with Options 86/87/88/89 and Option 7) and the 3739C broadband/millimeter-wave test set.
- E and W Band mmWave Modules The third configuration is to use external E and W band millimeter-wave modules with any model VectorStar (with Options 86/87/88/89 and Option 7) and the 3739C test set. The ME7838E system may also be configured for the above W band mm wave operation. With the addition of VDI modules, operation up to 1.1 THz can be achieved.

### E and W Band Operation Using the 3743E, 3744E-EE, or 3744E-EW mmWave Module



3743E Millimeter-Wave Modules



3744E-EE/3744E-EW Millimeter-Wave Module with Waveguide Adapter

The 3743E Broadband mmWave module can be adapted to a waveguide band output by adding an available waveguide band adapter and mounting flange. VectorStar menus automatically configure the system frequencies incorporating the 3743E module for banded operation. Using the 3743E modules provides the opportunity to sweep frequencies for broadband applications and quickly convert to waveguide configurations for banded measurements. The advantages of small compact modules with excellent RF performance and power range control can therefore be realized in both broadband and waveguide configurations when using the 3743E mmWave module. For systems where only waveguide band operation is required, the 3744E-EE or 3744E-EW mmWave module can be used.

The 3744E-EE or 3744E-EW mmWave module operates from 54 GHz to 110 GHz. The band supported is determined by the waveguide adapter connected to the 1 mm test port output of the 3744E-EE/EW module:

- 3744E-EE Configures the module for Extended E Band
- 3744E-EW Configures for Extended W Band

The RF input port of the 3744E-EE or 3744E-EW module is restricted below 54 GHz, however, the RF input port retains a DC connection to the 1 mm test port. Thus, the waveguide adapter can be removed for on-wafer applications from 54 GHz to 110 GHz operation and the on-wafer DUT can be biased through the RF input port.

| Band  | Frequency Range           | Waveguide Flange | Transmission/Reflection Module |
|-------|---------------------------|------------------|--------------------------------|
| Ext-E | 56 to 94 GHz <sup>a</sup> | WR-12            | 3744E-EE                       |
| Ext-W | 65 to 110 GHz             | WR-10            | 3744E-EW                       |

a. Operational to 95 GHz.

## Waveguide Band Specifications

### Port Power, Noise Floor, Dynamic Range – 3744E-EE/3744E-EW mmWave Modules

System dynamic range is defined as the ratio of the source power to the noise floor. Maximum Receiver Power is defined as the 0.2 dB compression point of the receiver at the waveguide port. Receiver dynamic range is defined as the ratio of maximum receive power to the noise floor. Noise Floor measurements are RMS, are made with no average in a 10 Hz IF bandwidth, and include an isolation calibration. All figures are typical.

#### 3744E-EE Extended-E Band (WR-12) Waveguide

| Frequency Range (GHz)   | Source Power (dBm) | Max. Receive Power (0.2 dB comp. pt.) (dBm) | Noise Floor (dBm) | System Dynamic Range (dB) | Receiver Dynamic Range (dB) |
|-------------------------|--------------------|---|-------------------|---------------------------|-----------------------------|
| 56 to 60                | -2                 | 11  | -111              | 109                       | 122                         |
| > 60 to 65              | 0                  | 11  | -106              | 106                       | 117                         |
| > 65 to 80              | -3                 | 11  | -109              | 106                       | 120                         |
| > 80 to 85              | -4                 | 11  | -112              | 108                       | 123                         |
| > 85 to 90              | -4                 | 11  | -110              | 106                       | 121                         |
| > 90 to 94 <sup>a</sup> | 0                  | 12  | -105              | 105                       | 117                         |

a. Operational to 95 GHz.

#### 3744E-EW Extended-W Band (WR-10) Waveguide

| Frequency Range (GHz) | Source Power (dBm) | Max. Receive Power (0.2 dB comp. pt.) (dBm) | Noise Floor (dBm) | System Dynamic Range (dB) | Receiver Dynamic Range (dB) |
|-----------------------|--------------------|---|-------------------|---------------------------|-----------------------------|
| 65 to 67              | 0                  | 11  | -106              | 106                       | 117                         |
| > 67 to 80            | -3                 | 11  | -109              | 106                       | 120                         |
| > 80 to 85            | -4                 | 11  | -112              | 108                       | 123                         |
| > 85 to 90            | -4                 | 11  | -110              | 106                       | 121                         |
| > 90 to 100           | 0                  | 12  | -105              | 105                       | 117                         |
| > 100 to 110          | -5                 | 12  | -110              | 105                       | 122                         |

### Power Range, Accuracy, Linearity, and Resolution

Accuracy is defined at -10 dBm or max rated power, whichever is lower. Linearity is defined as the incremental error between the accuracy test power level and 5 dB below. Typical.

| Frequency Range (GHz) | Range (dBm) |                   | Accuracy (dB) | Linearity (dB) | Resolution (dB) |
|-----------------------|-------------|-------------------|---------------|----------------|-----------------|
|                       | ME7838E     | ME7838E Option 62 |               |                |                 |
| 54 to 60              | -55 to -2   | -55 to -2         | ± 2.0         | ± 1.5          | 0.01            |
| > 60 to 65            | -55 to 0    | -55 to 0          | ± 2.0         | ± 1.5          | 0.01            |
| > 65 to 80            | -55 to -3   | -55 to -3         | ± 2.0         | ± 1.5          | 0.01            |
| > 80 to 85            | -55 to -4   | -55 to -4         | ± 2.0         | ± 1.5          | 0.01            |
| > 85 to 90            | -55 to -4   | -55 to -4         | ± 2.0         | ± 1.5          | 0.01            |
| > 90 to 100           | -55 to 0    | -55 to 0          | ± 3.0         | ± 2.0          | 0.01            |
| > 100 to 110          | -50 to -5   | -50 to -5         | ± 3.0         | ± 2.0          | 0.01            |

**Corrected System Performance/Uncertainties - 3744E-EE/3744E-EW mmWave Modules**

With 12-term Offset, Short, Sliding-Load, or LRL calibrations, using high precision waveguide sections and standards from the appropriate calibration kit.

**3744E-EE Extended-E Band (WR-12) Waveguide - 56 GHz to 94 GHz**

| Calibration Type | Directivity (dB) | Source Match (dB) | Load Match (dB) | Reflection Tracking (dB) | Transmission Tracking (dB) |
|------------------|------------------|-------------------|-----------------|--------------------------|----------------------------|
| Offset Short     | > 44             | > 33              | > 44            | ± 0.080                  | ± 0.100                    |
| LRL              | > 44             | > 43              | > 44            | ± 0.006                  | ± 0.006                    |

**3744E-EW Extended-W Band (WR-10) Waveguide - 65 GHz to 110 GHz**

| Calibration Type | Directivity (dB) | Source Match (dB) | Load Match (dB) | Reflection Tracking (dB) | Transmission Tracking (dB) |
|------------------|------------------|-------------------|-----------------|--------------------------|----------------------------|
| Offset Short     | > 40             | > 30              | > 46            | ± 0.080                  | ± 0.100                    |
| LRL              | > 40             | > 40              | > 46            | ± 0.006                  | ± 0.006                    |

**Measurement Uncertainties - Extended-E Band - SSLT**

The graphs give measurement uncertainties after the above calibration. The errors are worst case contribution of residual directivity, load and source match, frequency response and isolation, network analyzer dynamic accuracy, and connector repeatability. 10 Hz IF Bandwidth is used. For transmission uncertainties, it is assumed that  $S_{11}=S_{22}=0$ . For reflection uncertainties, it is assumed that  $S_{21}=S_{12}=0$ . All calibrations and measurements were performed at default port power. For other conditions, please use our free Exact Uncertainty Calculator software, available for download from the Anritsu web site at [www.anritsu.com](http://www.anritsu.com). The results below are typical.

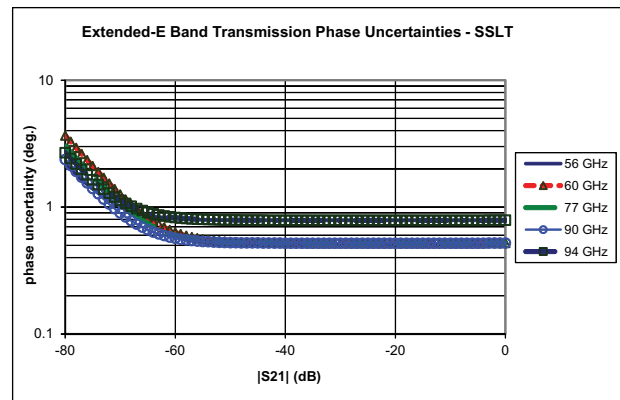
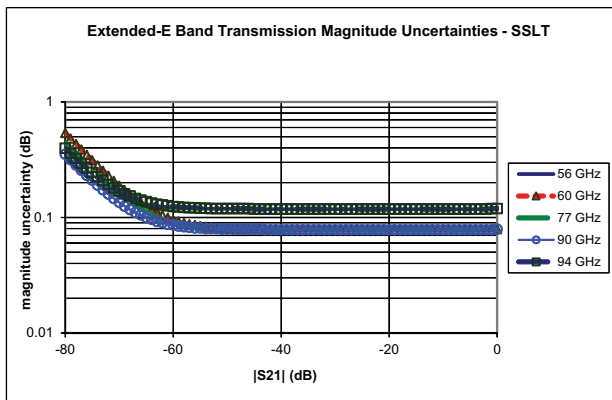
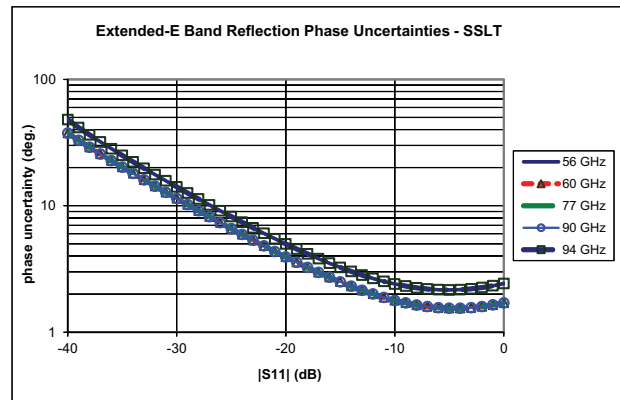
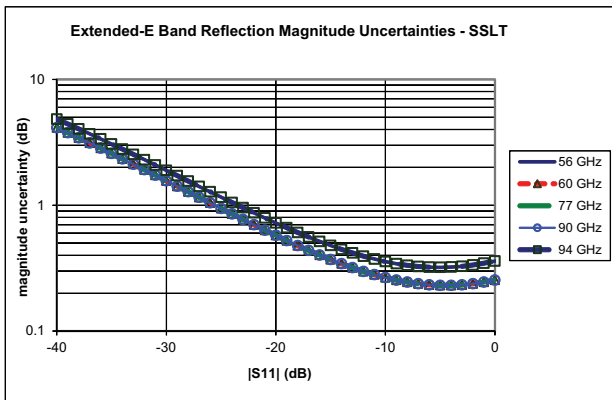

**Measurement Uncertainties – Extended-E Band – LRL**

The graphs give measurement uncertainties after the above calibration. The errors are worst case contribution of residual directivity, load and source match, frequency response and isolation, network analyzer dynamic accuracy, and connector repeatability. 10 Hz IF Bandwidth is used. For transmission uncertainties, it is assumed that  $S_{11}=S_{22}=0$ . For reflection uncertainties, it is assumed that  $S_{21}=S_{12}=0$ . All calibrations and measurements were performed at default port power. For other conditions, please use our free Exact Uncertainty Calculator software, available for download from the The results below are typical.

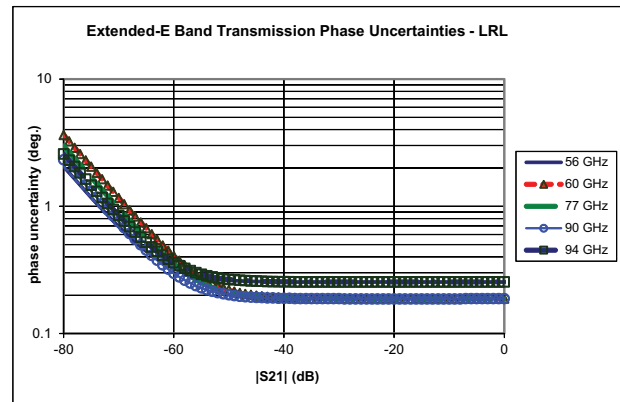
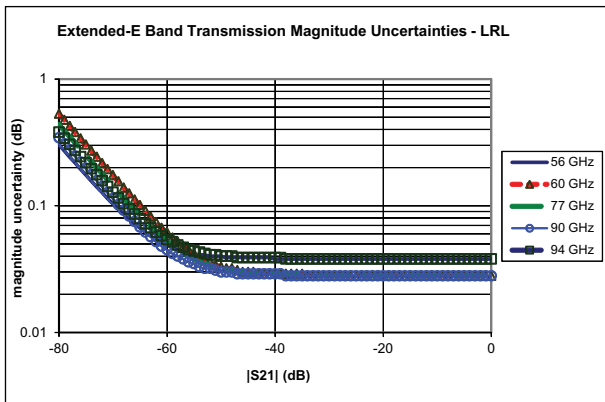
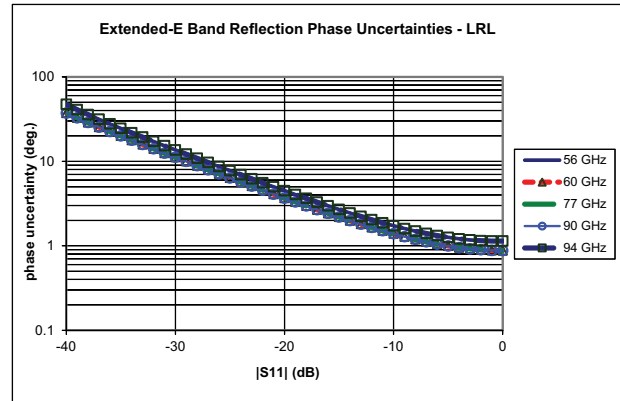
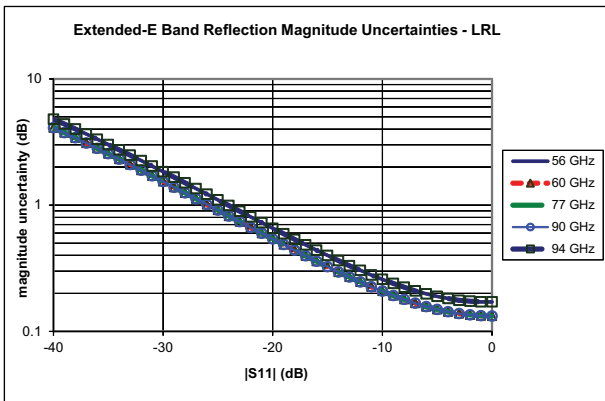

**Measurement Uncertainties – Extended-W Band – SSLT**

The graphs give measurement uncertainties after the above calibration. The errors are worst case contribution of residual directivity, load and source match, frequency response and isolation, network analyzer dynamic accuracy, and connector repeatability. 10 Hz IF Bandwidth is used. For transmission uncertainties, it is assumed that  $S_{11} = S_{22} = 0$ . For reflection uncertainties, it is assumed that  $S_{21} = S_{12} = 0$ . All calibrations and measurements were performed at default port power. For other conditions, please use our free Exact Uncertainty Calculator software, available for download from the The results below are typical.

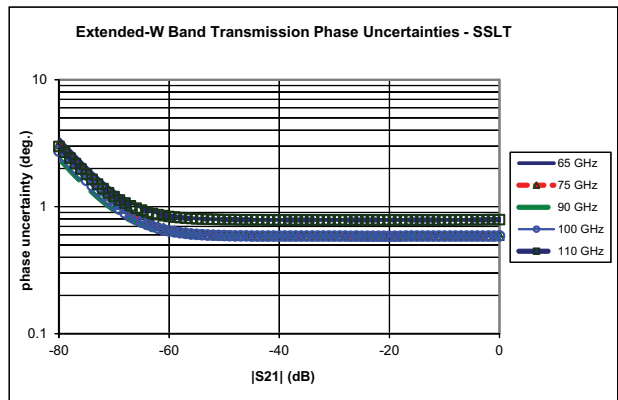
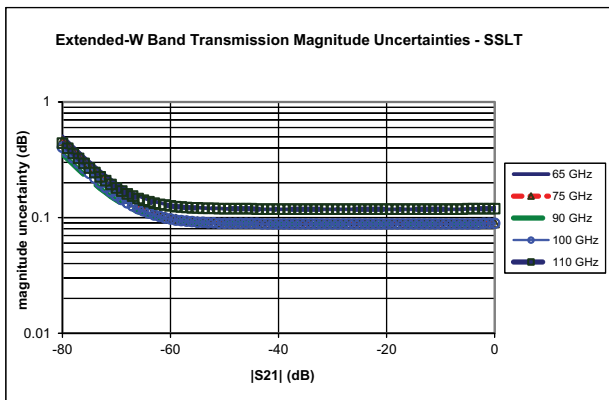
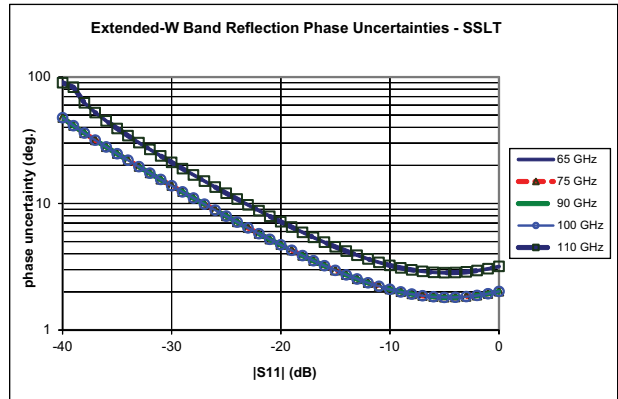
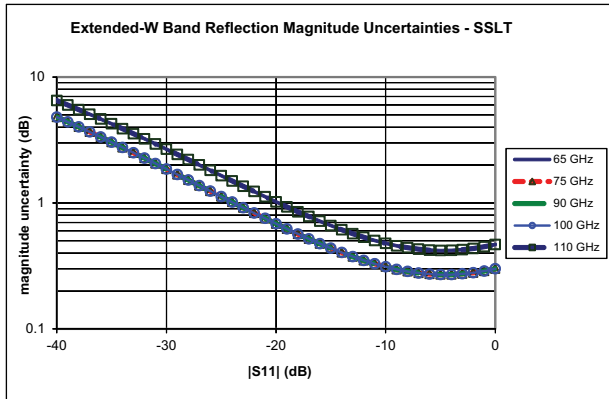

**Measurement Uncertainties – Extended-W Band – LRL**

The graphs give measurement uncertainties after the above calibration. The errors are worst case contribution of residual directivity, load and source match, frequency response and isolation, network analyzer dynamic accuracy, and connector repeatability. 10 Hz IF Bandwidth is used. For transmission uncertainties, it is assumed that  $S_{11} = S_{22} = 0$ . For reflection uncertainties, it is assumed that  $S_{21} = S_{12} = 0$ . All calibrations and measurements were performed at default port power. For other conditions, please use our free Exact Uncertainty Calculator software, available for download from the The results below are typical.

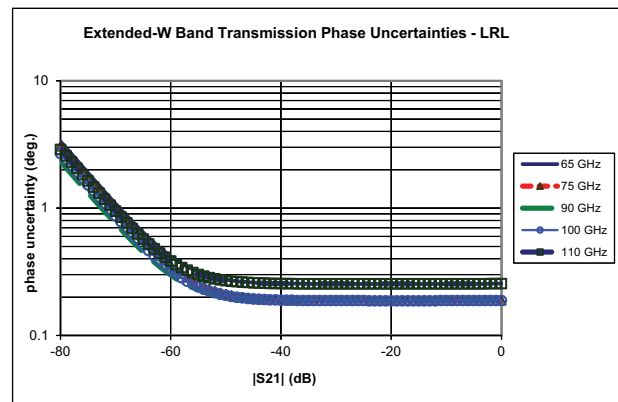
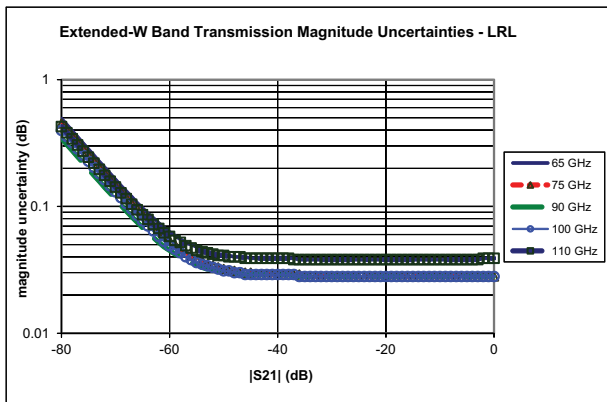
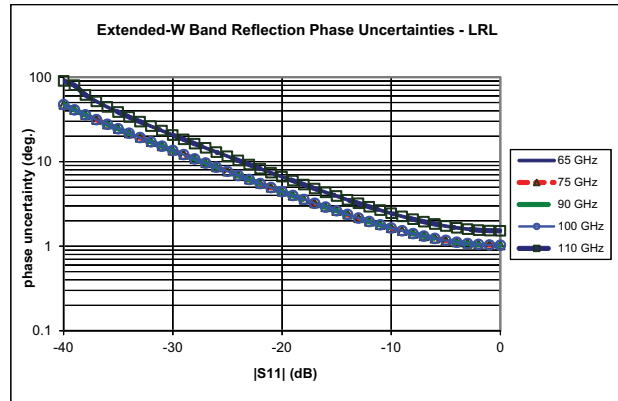
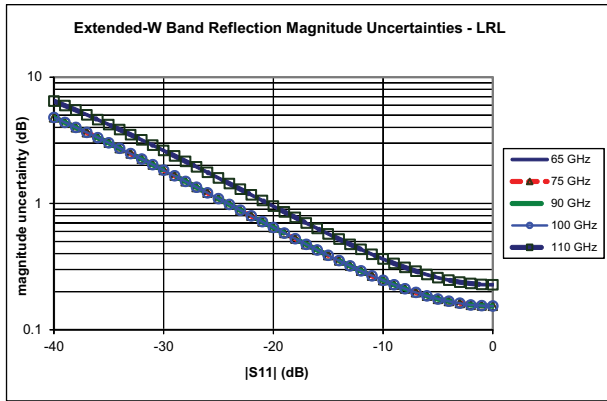

Millimeter-Wave Noise Figure Measurements with Option 41/48 and 3744E-Rx

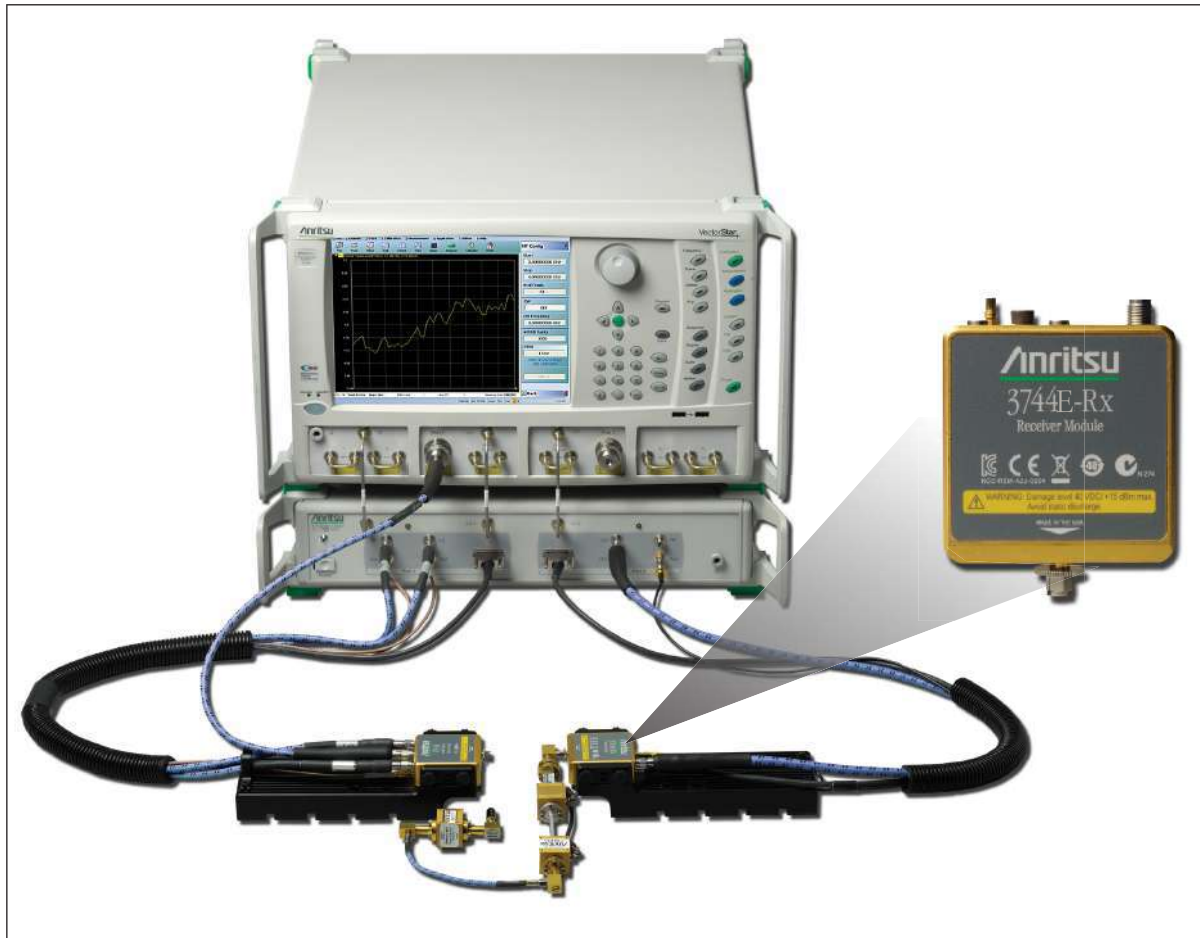

ME7838E with 3744E-Rx Receiver Module

The 3744E-Rx receiver module can be used with Option 41, Noise Figure, and the ME7838E mmWave or broadband system to perform mmWave noise figure measurements from 30 GHz to 110 GHz. The receiver bypasses the internal couplers (see block diagram on next page), maximizing the noise figure of the receiver for optimum noise figure measurement accuracy. The receiver is derived from the 3743E mmWave module and utilizes the same nonlinear transmission line technology for optimum mmWave performance. Using the advantages of the 3743E mmWave module system architecture provides a unique solution to mmWave noise figure measurements previously unavailable.

With Option 48, differential (and common-mode) noise figure measurements are possible in the same wide frequency ranges. In this case, two 3744A-Rx modules (along with needed pre-amplifiers/filters) are used to complete the differential receiver. While usually a 4-port system is used, a 2-port ME7838E can be used for the noise measurements as long as DUT gain information is available.

**Block Diagram – 3744E-Rx Receiver Module**

As with all cold source method noise figure measurements, the output of the DUT is first sent to an external composite receiver for pre-amplification. This ensures that the system noise figure is minimized for optimum measurement accuracy.

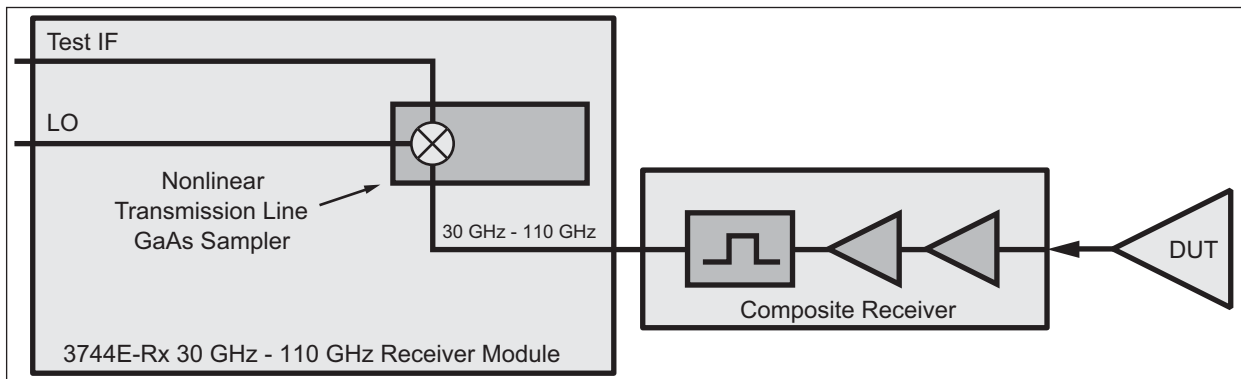

3744E-Rx Block Diagram

(Two composite receivers and two 3744A-Rx modules are used with Option 48 for differential or common-mode noise figure measurements.)

**3744E-Rx Receiver Compression, Noise Floor**

Receiver Compression Point is defined as the port power level beyond which the response may be compressed more than 0.2 dB relative to the normalization level. 10 Hz IF bandwidth is used to remove trace noise effects. All typical.

Noise Floor is relative to the receiver power calibration performed at -10 dBm. Typical.

| Frequency Range | Receiver Compression (dBm) <sup>a</sup> | Noise Floor (dBm) <sup>b</sup> |
|-----------------|---|--------------------------------|
| 30 to 54 GHz    | 0                                       | -124                           |
| 54 to 60 GHz    | 0                                       | -122                           |
| 60 to 67 GHz    | 0                                       | -117                           |
| 67 to 80 GHz    | 0                                       | -120                           |
| 80 to 85 GHz    | 0                                       | -123                           |
| 85 to 90 GHz    | 0                                       | -121                           |
| 90 to 95 GHz    | 0                                       | -121                           |
| 95 to 105 GHz   | 0                                       | -117                           |
| 105 to 110 GHz  | 0                                       | -122                           |

a. At the 3744E-Rx test port.

b. Excludes localized spurious responses and crosstalk.

### Waveguide Bands from 50 GHz to 1.1 THz

The VectorStar Millimeter-Wave system supports OML or VDI modules starting at 50 GHz. System performance is based on the specific mmWave module installed and appropriate cal kit. The mmWave modules need to provide IF levels of -15 dBm to -5 dBm when the RF drive is set to maximum in order to deliver specified dynamic range. Contact the vendor web site for additional information.



VDI and OML Millimeter-Wave Modules

### Block Diagram – Millimeter-Wave VNA System

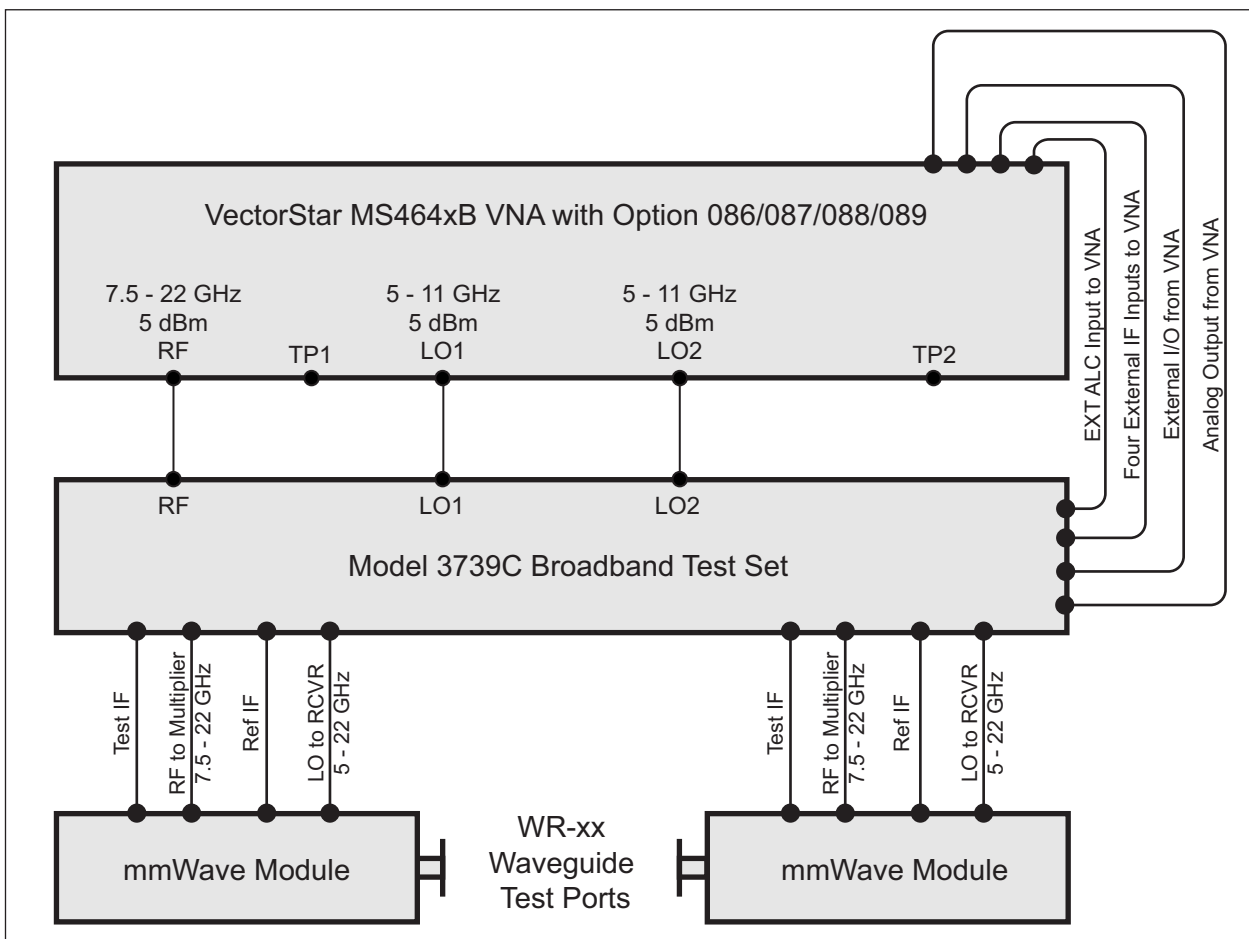

Millimeter-Wave Configuration Block Diagram

**VectorStar ME7838E Millimeter-Wave System with VDI Modules**

This section provides the specifications for the VectorStar MS4640B series microwave Vector Network Analyzers (VNAs) when configured with the Virginia Diodes, Inc. millimeter-wave (mmWave) frequency extension modules. The following frequency bands are supported:

| Waveguide Band  | WR15     | WR10      | WR8.0     | WR6.5      | WR5.1      | WR4.3      | WR3.4      | WR2.8      | WR2.2      | WR1.5      | WR1.0 <sup>a</sup> |
|-----------------|----------|-----------|-----------|------------|------------|------------|------------|------------|------------|------------|--------------------|
| Frequency (GHz) | 50 to 75 | 75 to 110 | 90 to 140 | 110 to 170 | 140 to 220 | 170 to 260 | 220 to 330 | 260 to 400 | 330 to 500 | 500 to 750 | 750 to 1100        |

a. Contact Anritsu

**System Configuration with VDI Modules**

The VectorStar Millimeter-Wave system provides control of VDI modules for frequency extension coverage up to 1.1 THz\*. MS4640B series VectorStar VNA may be configured for mmWave operation by adding the appropriate control option and test set. System requirements include:

- VectorStar VNA Model MS4642B, MS4644B, or MS4647B  
(Note: For 1.1 THz operation the 40 GHz MS4644B or higher model is required.)
- Options MS4640B Option 7, Receiver Offset  
MS4640B Option 86, 87, 88, or 89
- Test Set 3739C Test Set
- Cable SM6537 Interface Cable – Connection between VectorStar and the VDI mmWave module is provided with this interface cable.  
Each VDI module is equipped with a dedicated external power supply and DC cable.

**VDI Module Specifications**

- Specifications: Dynamic range (DR) specifications are valid for any MS4640B VectorStar VNA with appropriate options. Directivity specifications are valid when using appropriate VDI calibration kits. These specification results assume a through measurement with two TxRx Heads. All extender heads include a precision Test Port. The specifications here are typical and subject to change.
- Stability: Measured for 1 hour after a 1 hour system warm-up, in a stable environment with ideal cables.
- Dynamic Range: The dynamic range (RBW 10 Hz) is measured by first connecting two TxRx heads together and normalizing the un-calibrated S21 and S12. The heads are then disconnected and terminated with a waveguide short. The rms of the measured S21 & S12 give the system dynamic range.
- Test Port Power: Test Port Power is typical. Reduced power is possible at band edges.

**VDI Extenders-Summary of Specifications**

| Waveguide Band  | WR15  | WR12  | WR10   | WR8.0  | WR6.5   | WR5.1   | WR4.3   | WR3.4   | WR2.8   | WR2.2   | WR1.5 <sup>a</sup> | WR1.0 <sup>a</sup> |
|---|-------|-------|--------|--------|---------|---------|---------|---------|---------|---------|--------------------|--------------------|
| Frequency Coverage [GHz]                                    | 50-75 | 60-90 | 75-110 | 90-140 | 110-170 | 140-220 | 170-260 | 220-330 | 260-400 | 330-500 | 500-750            | 750-1100           |
| Dynamic Range BW = 10 Hz, [dB], (Typical)                   | 120   | 120   | 120    | 120    | 120     | 120     | 115     | 115     | 100     | 110     | 100                | 65                 |
| Dynamic Range BW = 10 Hz, [dB], minimum                     | 110   | 110   | 110    | 110    | 110     | 110     | 110     | 105     | 80      | 100     | 80                 | 45                 |
| Magnitude Stability [± dB]                                  | 0.1   | 0.1   | 0.1    | 0.15   | 0.25    | 0.25    | 0.3     | 0.3     | 0.5     | 0.5     | 0.4                | 0.5                |
| Phase Stability [± deg.]                                    | 1.5   | 1.5   | 1.5    | 2      | 4       | 4       | 4       | 6       | 6       | 6       | 4                  | 6                  |
| Test Port Power [dBm], (Typical)                            | 13    | 18    | 18     | 16     | 13      | 6       | 4       | 1       | -10     | -3      | -25                | -30                |
| Test Port Input Limit <sup>b</sup> [dBm, Saturation/Damage] | 30    | 30    | 30     | 30     | 30      | 30      | 28      | 26      | 16      | 10      | -3                 | -3                 |
| Directivity [dB]  | 30    | 30    | 30     | 30     | 30      | 30      | 30      | 30      | 30      | 30      | 30                 | 30                 |

a. Mini versions of these modules are available with higher port power and dynamic range.  
b. Test Port Input Limits are shown for standard test port power models only.

**VDI Module Head Configurations**

- TxRx Transmitter with two receivers (reference and measurement), and two couplers. Two TxRx heads are required for full two-port measurements.
- TxRef Transmitter with reference receiver and one coupler.
- Rx Measurement receiver.
- Tx Transmitter.

**VDI Module Options**

- Micrometer-Drive Variable Attenuator A 0 dB to 30 dB micrometer-drive variable attenuator option is available on TxRx and Tx modules up through WR1.5. If ordered, "-Attn" is added as an option suffix to the module model number. The attenuators reduce TPP and DR by as much as 8 dB in the WR3.4 and higher frequency bands and add approximately 2 in to the enclosure.
- Increased Test Port Power Options exist for increasing test port power in some full bands or in partial bands. Consult factory for more information.
- Non-Standard Frequency Bands Non-standard frequency bands or other specific needs are possible. Consult factory for more information.
- Custom Configuration Anritsu/VDI will work with customers to reconfigure any extender to meet specific needs.

ME7838E Measurement Examples Using VDI Millimeter-Wave Modules

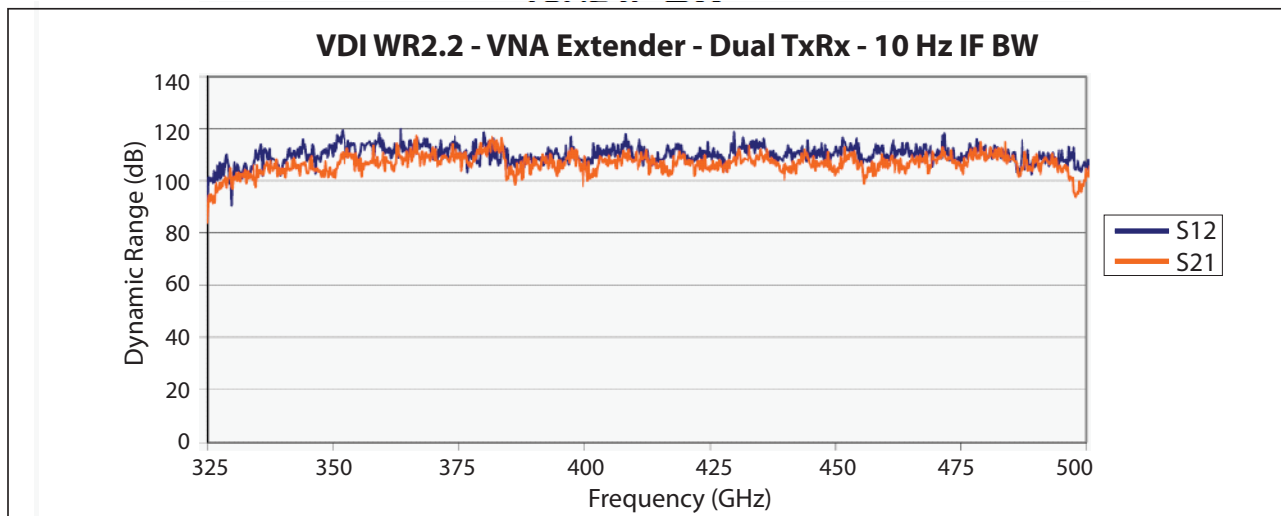

Typical Dynamic Range Plot of VDI WR2.2 Module - 10 Hz IFBW

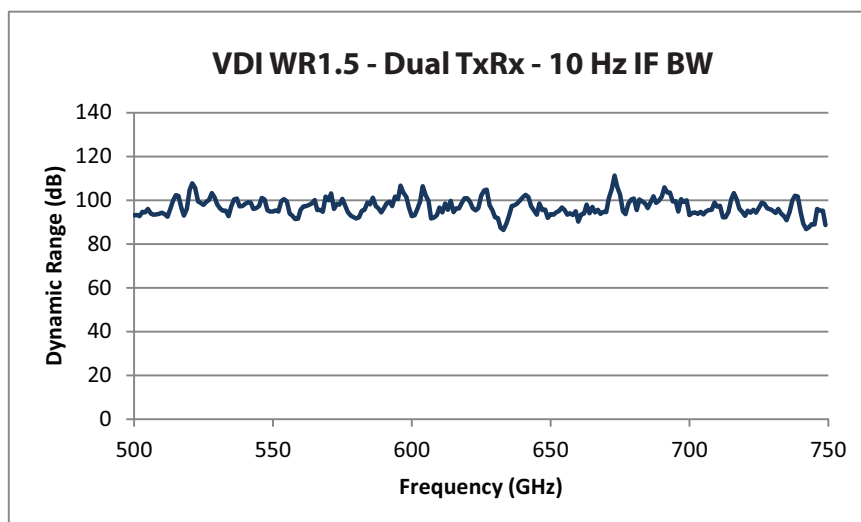

Typical Dynamic Range Plot of VDI WR1.5 Dual TxRx - 10 Hz IFBW

ME7838E 400 GHz Power Sweep with VDI WR2.2 TxRx Module

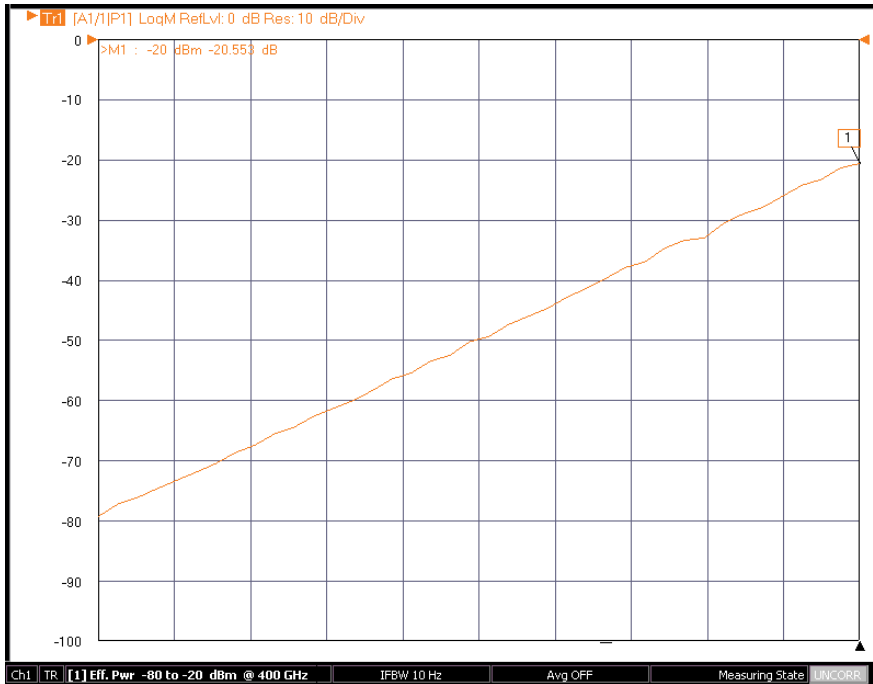

Typical real-time power sweep of VDI WR2.2 module using system power level control and no mechanical attenuators.

VectorStar ME7838E Millimeter-Wave System with OML Modules

This section provides specifications for the VectorStar MS4640B series microwave Vector Network Analyzers (VNAs) when configured with the OML millimeter-wave frequency extension modules.

|                      |   |
|----------------------|---|
| Description          | Each OML module must be equipped with a dedicated external power supply and DC cable. Connection between the VectorStar and the OML mmWave module is provided with the supplied interface cable.  |
| System Configuration | The VectorStar Millimeter-Wave system provides control of OML modules for frequency extension coverage up to 325 GHz. The MS4640B series VectorStar VNA may be configured for mmWave operation by adding the appropriate control option and test set. |
| System requirements  | MS4642B, MS4644B, or MS4647B Model VectorStar VNA<br>MS4640B Option 7, Receiver Offset<br>MS4640B Option 86, 87, 88, or 89<br>SM6537 Interface Cable<br>3739C Test Set  |
| Specifications       | Dynamic range specifications are valid for any MS4640B VectorStar VNA with appropriate options.<br>Directivity specifications are valid when using appropriate OML calibration kits.  |

OML Millimeter-Wave Extenders Summary Specifications

| OML "T/R" Models <sup>a</sup>                                  | Units     | Measurement                | V15VNA2-T/R      | V12VNA2-T/R      | V10VNA2-T/R       | V08VNA2-T/R       | V06VNA2-T/R        | V05VNA2-T/R        | V03VNA2-T/R        |
|--|-----------|----------------------------|------------------|------------------|-------------------|-------------------|--------------------|--------------------|--------------------|
| <b>Output Interface<sup>b</sup><br/>Operating Frequency</b>    | GHz       | -                          | WR-15<br>50 – 75 | WR-12<br>60 – 90 | WR-10<br>75 – 110 | WR-08<br>90 – 140 | WR-06<br>110 – 170 | WR-05<br>140 – 220 | WR-03<br>220 – 325 |
| <b>Test Port Output Power<sup>c</sup></b>                      | dBm       | <b>Minimum<br/>Typical</b> | +5<br>+8         | +2<br>+5         | +3<br>+5          | -8<br>-4          | -15<br>-10         | -18<br>-13         | -23                |
| <b>Test Port Input Power at 0.1 dB Compression<sup>d</sup></b> | dBm       | <b>Typical</b>             | +8               | +8               | +6                | +4                | -5                 | -5                 | -5                 |
| <b>Test Port Match<sup>e</sup></b>                             | dB        | <b>Typical</b>             | >17              | >17              | >17               | >17               | >15                | >15                | >9                 |
| <b>Residual Source and Load Match</b>                          | dB        | <b>Typical</b>             | >35              | >35              | >35               | >35               | >35                | >35                | >33                |
| <b>Test Dynamic Range<sup>e</sup></b>                          | dB        | <b>Minimum<br/>Typical</b> | 92<br>>105       | 92<br>>105       | 95<br>>110        | 90<br>>105        | 80<br>>95          | 80<br>>95          | 60<br>>75          |
| <b>Reflection and Transmission Tracking<sup>f</sup></b>        | dB<br>Deg | <b>Magnitude<br/>Phase</b> | ±0.2<br>±2       | ±0.2<br>±2       | ±0.2<br>±2        | ±0.3<br>±3        | ±0.4<br>±5         | ±0.4<br>±6         | ±0.4<br>±8         |
| <b>Coupler Directivity<sup>c</sup></b>                         | dB        | <b>Typical</b>             | >35              | >35              | >35               | >33               | >30                | >30                | >30                |
| <b>Size<sup>g</sup></b>  | in        | <b>(L x W x H)</b>         | 13.0 x 4.3 x 2.7 |                  |                   |                   |                    |                    |                    |

a. Specifications are typical and subject to change without notice.

b. Test Port Flange Configuration is compatible with MIL-DTL-3922/67D (UG 387/U-M).

c. As there are no internationally recognized power standards above 110 GHz, any power data supplied above 110 GHz is traceable only to OML's calorimeter.

d. Not Tested.

e. Measured at 10 Hz IF bandwidth.

f. At +25 °C. Measured for 1 hr after 1 hr warm-up. Based on "perfect" RF and LO test cables not moved after warm-up and calibration. Not tested.

g. Height excludes the adjustable rubber feet; length and depth dimensions exclude the output waveguide length.

### Standard Capabilities for All Configurations

For standard capabilities of the VectorStar VNAs, please see the **VectorStar MS4640B Series VNA Technical Data Sheet – 11410-00611**, available at [www.anritsu.com](http://www.anritsu.com).

### Mechanical and Environmental

**MS4640B Vector Network Analyzer** Dimensions without rack mount option.

|        |  |
|--------|--|
| Height | 267 mm body (6u)<br>286 mm between feet outer edges  |
| Width  | 426 mm body<br>457 mm between feet outer edges<br>487 mm between front panel handles outer edges |
| Depth  | 502 mm body<br>591 mm between handle and foot outer edges  |
| Weight | < 28 kg (< 60 lbs), Typical weight for a fully-loaded MS4647B VNA                                |

**3739C Broadband/Millimeter-Wave Test Set** Dimensions without rack mount option.

|        |  |
|--------|--|
| Height | 89 mm body (2u)<br>108 mm between feet outer edges   |
| Width  | 426 mm body<br>457 mm between feet outer edges<br>487 mm between front panel handles outer edges |
| Depth  | 502 mm body<br>591 mm between handle and foot outer edges  |
| Weight | 5.75 kg  |

**3743E Millimeter-Wave Module**

|        |         |
|--------|---------|
| Height | 21.5 mm |
| Width  | 54 mm   |
| Depth  | 55.3 mm |
| Weight | 0.27 kg |

**Environmental – Operating** Conforms to MIL-PRF-28800F (Class 3)

|                   |  |
|-------------------|--|
| Temperature Range | 0 °C to +50 °C without error codes*<br>* Except for 'unleveled' error messages that may occur at the extreme edges of the temperature range above. |
| Relative Humidity | 5 % to 95 % at +30 °C, Non-condensing  |
| Altitude          | 4,600 m (15,000 feet)  |

**Environmental – Non-Operating**

|                   |  |
|-------------------|--|
| Temperature Range | -40 °C to +71 °C                       |
| Relative Humidity | 0 % to 90 % at +30 °C , Non-condensing |
| Altitude          | 4,600 m (15,000 feet)                  |

### Regulatory Compliance

|                           |   |
|---------------------------|---|
| European Union            | EMC 2014/30/EU, EN 61326:2013, CISPR 11/EN 55011, IEC/EN 61000-4-2/3/4/5/6/11<br>Low Voltage Directive 2014/35/EU<br>Safety EN 61010-1:2010<br>RoHS Directive 2011/65/EU & Amendment 2015/683 |
| United Kingdom            | EMC SI 2016/1091; BS EN 55011 & BS EN 61000-4-2/3/4/5/6/8/11<br>Consumer Protection (Safety) SI 2016/1011; BS EN 61010-1:2010<br>Environmental Protection SI 2012/3032; 2011/65/EU & 2015/863 |
| Canada                    | ICES-1(A)/NMB-1(A)  |
| Australia and New Zealand | RCM AS/NZS 4417:2012  |
| South Korea               | KCC-REM-A21-0004  |

### Warranty

The ME7838E Series VNAs and related accessories offer a 3-year warranty from the date of shipment (excluding OML and VDI modules). Please contact your local service center for additional warranty coverage.

## Calibration and Correction Capabilities

|   |   |
|---|---|
| <b>Calibration Methods</b>                    | Short-Open-Load-Through (SOLT) with Fixed or Sliding Load and supporting .s1p-defined cal kits<br>Offset-Short-Offset-Short-Load-Through (SSLT) with Fixed or Sliding Load<br>Triple-Offset-Short-Through (SSST) and overdetermined offset short (mSSST)<br>Short-Open-Load-Reciprocal (SOLR) or Unknown Through Method (SSLR, SSSR)<br>Line-Reflect-Line (LRL) / Line-Reflect-Match (LRM) – (up to 5 bands supported for multi-line configurations)<br>Thru-Reflect-Line (TRL) - (up to 5 bands supported)<br>Advanced-LRM (A-LRM™) for improved on-wafer calibrations<br>mTRL (Multiline TRL)<br>Hybrid Cals (allows combination of sub-cals of different type or media)<br>AutoCal™<br>Thru Update available<br>Secondary match correction available for improved low insertion loss measurements                                    |
| <b>Correction Models</b>                      | 2-Port (Forward, Reverse, or both directions)<br>1-Port ( $S_{11}$ , $S_{22}$ , or both)<br>Transmission Frequency Response (Forward, Reverse, or both directions)<br>Reflection Frequency Response ( $S_{11}$ , $S_{22}$ , or both)  |
| <b>Merged Calibration</b>                     | Merge multiple calibration methods over bands of frequency points.<br>Note that merge does not need to be used for broadband coaxial (SOLT/R-SSST/R) 1 mm or 0.8 mm calibrations using Anritsu calibration kits. These can be done as one unified calibration.  |
| <b>Coefficients for Calibration Standards</b> | Use the Anritsu calibration kit USB Memory Device to load kit coefficients and characterization files.<br>Enter manual coefficients into user-defined locations.<br>Use complex load models.  |
| <b>Reference Impedance</b>                    | Modify the reference impedance from 50 $\Omega$ to any impedance greater than 0 $\Omega$ .  |
| <b>Interpolation</b>                          | Allows interpolation between calibration frequency points. Accuracy will be reduced at non-calibration frequencies and that degradation is dependent on the frequency step size in the initial calibration and the electrical length of the user's setup.   |
| <b>Adapter Removal Calibration</b>            | Characterizes and “removes” an adapter that is used during calibration that will not be used for subsequent device measurements; for accurate measurement of non-insertable devices.  |
| <b>Dispersion Compensation</b>                | Selectable as Coaxial, other non-dispersive (e.g., for coplanar waveguide), Waveguide, or Microstrip.   |
| <b>Power</b>                                  |   |
| Power Meter Correction                        | Different power meter calibrations are available to enhance power accuracy at the desired reference plane. The source power will match the target calibration power, as read by the power meter, to within -0.1 dB for short periods of time (determined by thermal drift of the system and the power meter). The absolute accuracy of the calibrated power will be dependent on the power meter and sensor used.   |
| Flat Power Calibrations                       | A flat power calibration (when in frequency sweep mode) is available at a user-selectable power level, if it is within the power adjustment range of the internal source. The flat power correction is applied to other power levels directly as an offset. Multiple power meters/sensors may be needed depending on the frequency range. An adapter may be required to the 1mm module test port.   |
| Linear Power Calibrations                     | A linear power calibration is performed over a range of power levels for use in power sweep mode and is performed at a specified frequency or frequency range (for multifrequency gain compression).  |
| External Power Meter                          | Both calibrations are performed using an external power meter (Anritsu ML2438A, ML248xB, ML249xA, Agilent 437B (or equivalent), Keysight N191XA, Rhode and Schwarz NRP2 meter with a broadband 110 GHz sensor, or Elva DPM power meter) over the Dedicated GPIB port, or a USB power sensor (Anritsu MA24106A, MA24108A, MA24118A, MA24126A, MA24208A, MA24218A, MA24330A, MA24340A, MA24350A, MA24507A) connected to a USB port.<br><br>Note: Usage of the MA24500A series sensor requires a dual USB Type A male to single USB Type A female cable to supply needed current draw. Because of certain bandwidth requirements, the MA24500A series can only be used for power calibrations above nominally -35 dBm on VectorStar. Accuracy with the MA24500A series of sensors (when used with VectorStar) may be degraded below 1 MHz. |
| <b>Embedding/De-embedding</b>                 | The MS4640B is equipped with an Embedding/De-embedding system.  |
| De-embedding                                  | De-embedding is generally used for removal of test fixture contributions, modeled networks and other networks described by S-parameters (s2p files) from measurements.  |
| Embedding                                     | Similarly, the Embedding function can be used to simulate matching circuits for optimizing amplifier designs or simply adding effects of a known structure to a measurement.  |
| Multiple Networks                             | Multiple networks can be embedded/de-embedded and changing the port and network orientations is handled easily.   |
| Extraction Utility                            | An extraction utility is part of this package that allows the easier computation of de-embedding files based on some additional calibration steps and measurements.   |
| <b>Impedance Conversion</b>                   | Allows entry of different impedances (complex values) for different ports.  |

Mechanical Calibration/Verification Kits

**W1 (1 mm) Calibration/Verification Kit, 3656B**

Provides 12-term SOLT or Triple Offset Short calibrations, for W1 (1 mm) devices, and two verification standards. The -3 options adds .s1p standards definition files for reduced calibration-related uncertainties.



| 3656B Cal Kit Contains:                                       | Additional Information (Typical)            | Quantity | Part Number |
|---|---|----------|-------------|
| Offset Short W1 (male)  | Offset: 2.020 mm                            | 1        | 23W50-1     |
| Offset Short W1 (male)  | Offset: 2.650 mm                            | 1        | 23W50-2     |
| Offset Short W1 (male)  | Offset: 3.180 mm                            | 1        | 23W50-5     |
| Offset Short W1 (female)                                      | Offset: 2.020 mm                            | 1        | 23WF50-1    |
| Offset Short W1 (female)                                      | Offset: 2.650 mm                            | 1        | 23WF50-2    |
| Offset Short W1 (female)                                      | Offset: 3.180 mm                            | 1        | 23WF50-5    |
| Open W1 (male)  | Offset: 1.510 mm                            | 1        | 24W50       |
| Open W1 (female)  | Offset: 1.930 mm                            | 1        | 24WF50      |
| Fixed Termination W1 (male)                                   |   | 1        | 28W50       |
| Fixed Termination W1 (female)                                 |   | 1        | 28WF50      |
| Adapter, W1 (male) to Fixed SC <sup>a</sup> Connector         |   | 1        | 33W50       |
| Adapter, W1 (female) to Fixed SC <sup>a</sup> Connector       |   | 1        | 33WF50      |
| Interchangeable Slider for SC <sup>a</sup> Connector (male)   |   | 1        | -           |
| Interchangeable Slider for SC <sup>a</sup> Connector (female) |   | 1        | -           |
| Locking Keys for SC <sup>a</sup> Connectors                   |   | 2        | -           |
| Pin Exchange Tool for SC <sup>a</sup> Connectors              | Contains 1 male pin                         | 1        | 01-402      |
| Adapter, W1 (male) to W1 (female)                             |   | 1        | 33WWF50     |
| Adapter, W1 (male) to W1 (male)                               |   | 1        | 33WW50      |
| Adapter, W1 (female) to W1 (female)                           |   | 1        | 33WFWF50    |
| Stepped Impedance ThruLine, W1 (male - female)                | Verification Device                         | 1        | 18WWF50-1B  |
| 50 Ω matched ThruLine, W1 (male - female)                     | Verification Device                         | 1        | 18WWF50-1   |
| Torque Wrench   | 6 mm, 5.4 N·cm (4 lbf·in)                   | 1        | 01-504      |
| Open-ended Wrench   | 6 mm / 7 mm                                 | 1        | 01-505      |
| Coefficients for standards                                    | On USB Memory Device and 3.5 in Floppy Disk | 1        | -           |

a. SC Connectors are a solution for accurate calibrations for non-insertable 1 mm devices. Users can change the gender of the SC connector using the provided tool, pin, sliders, and locking keys to ensure the best pin-depth, thus calibrations are valid after changing the gender of the adapter.

**Test Port Cables**

**Test Port Cables, Flexible, High Performance**

| Description                                  | Frequency Range | Impedance | Length (cm) | Insertion Loss (dB) | Return Loss (dB) | Part Number |
|--|-----------------|-----------|-------------|---------------------|------------------|-------------|
| W1 (1 mm) (male)<br>to<br>W1 (1 mm) (female) | DC to 110 GHz   | 50 Ω      | 10          | 1.74                | ≥ 14             | 3671W1-50-1 |
|  |                 |           | 13          | 2.23                | ≥ 14             | 3671W1-50-2 |
|  |                 |           | 16          | 2.74                | ≥ 14             | 3671W1-50-3 |



3671W1-50-X Flexible Test Cables

**Precision Adapters, Attenuators, and Other Components**

Anritsu offers a complete line of precision adapters and attenuators.



### Ordering Information

The ME7838E Broadband/Millimeter-Wave VNA System provides single sweep coverage from 70 kHz to 110 GHz and consists of the following standard components and optional accessories described in the sections below:

#### ME7838E Broadband System, 70 kHz to 110 GHz

| Action  | Part Number and Description  | Additional Information   |
|---|--|--|
| Order the base VectorStar model with the listed components and options: | MS4647B, 70 kHz to 70 GHz VNA<br>MS4640B-007, Receiver Offset<br>MS4640B-070, 70 kHz Frequency Coverage<br>3739C, Broadband Test Set with 36 inch interface cables<br>3743E, Millimeter-Wave Module, 2 each<br>ME7838E-SS020, On-site system assembly and verification   |  |
| Include one of the following:   | MS4647B-086, MS4647B with ME7838E system option  | MS4647B-088 is ordered when Option 31 is included.   |
|   | MS4647B-087, MS4647B with ME7838E system option and Option 51, or 61, or 62  | MS4647B-089 is ordered when Option 31 is included.   |
| Include one of the following:   | 806-206-R, 1.85 mm coaxial VNA RF cables, 24", M-F, 2 each   |  |
|   | 806-209-R, 1.85 mm coaxial VNA RF cables, 36", M-F, 2 each   |  |
| Add options if desired:   | Option 51, or 61, or 62:<br>MS4647B-051 – External VNA Loops<br>MS4647B-061 – Active Measurement Suite, 2 Attenuators<br>MS4647B-062 – Active Measurement Suite, 4 Attenuators   |  |
|   | MS4640B-070 – for 70 kHz operation in base VNA<br>MS4640B-002 – for Time Domain<br>MS4647B-031 – Dual Source Architecture<br>MS4640B-035 – IF Digitizer<br>MS4640B-041 – Noise Figure<br>MS4640B-042 – PulseView™<br>MS4640B-043 – DifferentialView™<br>MS4640B-048 – Differential Noise Figure<br>MS4640B-049 – Spectrum Analysis | MS4647B-031 requires Option 88 or 89.<br><br>For other available options, see <a href="#">"ME7838E Broadband/Millimeter-Wave System Options"</a> |
|   | MS4640B-001, MS4640B Rack Mount<br>3739C-001, 3739C Rack Mount   |  |
|   | ME7838E-098 - Standard Calibration, ISO 17025 compliant, without data<br>ME7838E-099 - Premium Calibration, ISO 17025 compliant, with data   |  |

**ME7838E Waveguide-Band System to 110 GHz – 3744E-EE or 3744E-EW mmWave Modules**

Configuration for ME7838E Millimeter-Wave System using 3744E-EE or 3744E-EW mmWave Modules:

| Action  | Part Number and Description  | Additional Information  |
|---|--|---|
| Choose and order one of the two base VectorStar models with options listed: | MS4644B VNA, 10 MHz to 40 GHz<br>MS4640B-007, Receiver Offset<br>MS4644B-086 or -087 or -088 or -089   | MS4644B-087 is ordered when Option 51, or 61, or 62 is included.<br>MS4644B-088 is ordered when Option 31 is included and Option 51, or 61, or 62 is <i>excluded</i> .<br>MS4644B-089 is ordered when Option 31 <i>and</i> Option 51, or 61, or 62 is <i>included</i> . |
|   | MS4647B VNA, 10 MHz to 70 GHz<br>MS4640B-007, Receiver Offset<br>MS4647B-086 or -087 or -088 or -089   | MS4647B-087 is ordered when Options 51, 61, or 62 are included.<br>MS4647B-088 is ordered when Option 31 is included and Option 51, or 61, or 62 is <i>excluded</i> .<br>MS4647B-089 is ordered when Option 31 <i>and</i> Option 51, or 61, or 62 is <i>included</i> .  |
| Order Test Set  | 3739C mmWave Test Set  |   |
| Choose and order Extended-E or Extended-W Band Modules:                     | 3744A-EE, 56 GHz to 94 GHz Extended E Band module, 2 each  |   |
|   | 3744A-EW, 65 GHz to 110 GHz Extended W Band module, 2 each   |   |
| Add options if desired:   | Option 51, or 61, or 62:<br>MS464xB-051 – External VNA Loops<br>MS464xB-061 – Active Measurement Suite, 2 Attenuators<br>MS464xB-062 – Active Measurement Suite, 4 Attenuators   |   |
|   | MS4640B-070 – for 70 kHz operation in base VNA<br>MS4640B-002 – for Time Domain<br>MS464xB-031 – Dual Source Architecture<br>MS4640B-035 – IF Digitizer<br>MS4640B-041 – Noise Figure<br>MS4640B-042 – PulseView™<br>MS4640B-043 – DifferentialView™<br>MS4640B-048 – Differential Noise Figure<br>MS4640B-049 – Spectrum Analysis | MS464xB-031 requires Option 88 or 89.<br><br>For other available options, see “ <a href="#">ME7838E Broadband/Millimeter-Wave System Options</a> ”  |
|   | MS4640B-001, MS4640B Rack Mount<br>3739C-001, 3739C Rack Mount   |   |
| Accessories   | 35WR12WF-EE – Precision Waveguide to Coax Adapter Kit, 56 GHz to 94 GHz, WR-12 to W1 (f)   |   |
|   | 35WR10WF-EW – Precision Waveguide to Coax Adapter Kit, 65 GHz to 110 GHz, WR-10 to W1 (f)  |   |

**ME7838E-Waveguide-Band System – OML/VDI mmWave Modules**

ME7838E Waveguide-band System using OML or VDI millimeter-wave modules:

| Action   | Part Number and Description  | Additional Information  |
|--|--|---|
| Choose and order one of the three base VectorStar models with options listed:    | MS4642B VNA, 10 MHz to 20 GHz<br>MS4642B-007, Receiver Offset<br>MS4642B-061 or MS4642B-062<br>MS4642B-087 or MS4642B-089  | MS4642B-061 includes Active Device Measurements, with 2 Step Attenuators<br>MS4642B-062 includes Active Device Measurements, with 4 Step Attenuators<br>MS4642B-089 is ordered when Option 31 is included.  |
|  | MS4644B VNA, 10 MHz to 40 GHz<br>MS4640B-007, Receiver Offset<br>MS4644B-086 or -087 or -088 or -089   | MS4644B-087 is ordered when Options 51, 61, or 62 are included.<br>MS4644B-088 is ordered when Option 31 is included and Option 51, or 61, or 62 is <i>excluded</i> .<br>MS4644B-089 is ordered when Option 31 <i>and</i> Option 51, or 61, or 62 is <i>included</i> .        |
|  | MS4647B VNA, 10 MHz to 70 GHz<br>MS4640B-007, Receiver Offset<br>MS4647B-086 or -087 or -088 or -089   | MS4647B-087 is ordered when Options 51, 61, or 62 are included.<br>MS4647B-088 is ordered when Option 31 is <i>included</i> and Option 51, or 61, or 62 is <i>excluded</i> .<br>MS4647B-089 is ordered when Option 31 <i>and</i> Option 51, or 61, or 62 is <i>included</i> . |
| Order:   | 3739C mmWave Test Set  |   |
|  | SM6537 Interface Cables (2) for OML/VDI mmWave Modules   | Does not include DC cable. DC supply is provided by mmWave module power supply.   |
| Choose and order one of the two appropriate millimeter-wave module combinations: | 2 each TxRx transmission and reflection millimeter-wave modules  | Choose appropriate OML or VDI modules. Contact Anritsu Company for ordering information.  |
|  | 1 each TxRx transmission and reflection module, and 1 each Tx transmission only module   |   |
| Add options if desired:  | Option 51, or 61, or 62:<br>MS464xB-051 – External VNA Loops<br>MS464xB-061 – Active Measurement Suite, 2 Attenuators<br>MS464xB-062 – Active Measurement Suite, 4 Attenuators   |   |
|  | MS4640B-070 – for 70 kHz operation in base VNA<br>MS4640B-002 – for Time Domain<br>MS464xB-031 – Dual Source Architecture<br>MS4640B-035 – IF Digitizer<br>MS4640B-041 – Noise Figure<br>MS4640B-042 – PulseView™<br>MS4640B-043 – DifferentialView™<br>MS4640B-048 – Differential Noise Figure<br>MS4640B-049 – Spectrum Analysis | MS464xB-031 requires Option 88 or 89<br><br>For other available options, see “ <a href="#">ME7838E Broadband/Millimeter-Wave System Options</a> ”   |

**Calibration/Verification Kits**

|         |  |
|---------|--|
| 3656B   | W1 (1 mm) Calibration/Verification Kit                                       |
| 3656B-3 | W1 (1 mm) Calibration/Verification Kit, With .s1p Standard Definitions Files |
| 3655V   | WR-15 Waveguide Calibration Kit, Without Sliding Loads                       |
| 3655V-1 | WR-15 Waveguide Calibration Kit, With Sliding Loads                          |
| 3655E   | WR-12 Waveguide Calibration Kit, Without Sliding Loads                       |
| 3655E-1 | WR-12 Waveguide Calibration Kit, With Sliding Loads                          |
| 3655W   | WR-10 Waveguide Calibration Kit, Without Sliding Loads                       |
| 3655W-1 | WR-10 Waveguide Calibration Kit, With Sliding Loads                          |
| 3650A   | SMA/3.5 mm Calibration Kit, Without Sliding Loads                            |
| 3650A-1 | SMA/3.5 mm Calibration Kit, With Sliding Loads                               |
| 3652A   | K Calibration Kit, With Pin Depth Gauge                                      |
| 3652A-2 | K Calibration Kit, With No Pin Depth Gauge                                   |
| 3652A-3 | K Calibration Kit, With Pin Depth Gauge and .s1p Characterization Files      |
| 3652A-4 | K Calibration Kit, With .s1p Characterization Files                          |
| 3654D   | V Calibration Kit, With Pin Depth Gauge                                      |
| 3654D-2 | V Calibration Kit, With No Pin Depth Gauge                                   |
| 3654D-3 | V Calibration Kit, With Pin Depth Gauge and .s1p Characterization Files      |
| 3654D-4 | V Calibration Kit, With .s1p Characterization Files                          |
| 3657    | V Multi-Line Calibration Kit, Without Shorts                                 |
| 3657-1  | V Multi-Line Calibration Kit, With Shorts                                    |

**External Power Meters/Sensors**

|          |  |
|----------|--|
| ML243xA  | CW Power Meter, Single Input or Dual Input<br>Recommended Power Sensors: SC7770, MA247xD, MA244xD, MA248xD, MA2400xA   |
| ML248xB  | Wideband Power Meter, Single Input or Dual Input<br>Recommended Power Sensors: MA249xA, MA2411B  |
| ML249xA  | Pulse Power Meter, Single Input or Dual Input<br>Recommended Power Sensors: MA249xA, MA2411B   |
| MA24106A | USB Power Sensor, 50 MHz to 6 GHz  |
| MA24108A | USB Power Sensor, 10 MHz to 8 GHz  |
| MA24118A | USB Power Sensor, 10 MHz to 18 GHz   |
| MA24126A | USB Power Sensor, 10 MHz to 26 GHz   |
| MA24330A | USB Power Sensor, 10 MHz to 33 GHz   |
| MA24340A | USB Power Sensor, 10 MHz to 40 GHz   |
| MA24350A | USB Power Sensor, 10 MHz to 50 GHz   |
| MA24507A | Power Master™ Frequency Selectable mmWave Power Analyzer, 9 kHz to 70 GHz  |
| MA24510A | Power Master™ Frequency Selectable mmWave Power Analyzer, 9 kHz to 110 GHz<br>Note that usage of the MA24507A or MA24510A Power Master™ sensor requires connection to two USB ports to supply needed current draw. |

**Test Port Cables, Flexible, High Performance**

|               |  |
|---------------|--|
| 3671W1-50-1   | W1 (male) to W1 (female), 1 each, 10.0 cm (3.9 in)             |
| 3671W1-50-2   | W1 (male) to W1 (female), 1 each, 13.0 cm (5.1 in)             |
| 3671W1-50-3   | W1 (male) to W1 (female), 1 each, 16.0 cm (6.3 in)             |
| 3671KFS50-60  | K (female) to 3.5 mm (male) cable, 60 cm (one cable)           |
| 3671KFK50-60  | K (female) to K (male) cable, 60 cm (one cable)                |
| 3671KFK50-100 | K (female) to K (male) cable, 1 each, 100 cm (one cable)       |
| 3671KFKF50-60 | K (female) to K (female) cable, 1 each, 60 cm (one cable)      |
| 3671VVF50-60  | V (female) to V (male) cable, 1 each, 60 cm (one cable)        |
| 3671VVF50-100 | V (female) to V (male) cable, 1 each, 100 cm (one cable)       |
| 3671KFSF50-60 | K (female) to 3.5 mm (female) cable, 1 each, 60 cm (one cable) |
| 3671VVF50-60  | V (female) to V (female) cable, 1 each, 60 cm (one cable)      |

**Adapters**

|                      |  |
|----------------------|--|
| 34WV50               | W1 (male) to V (male) Adapter, W1 (1 mm) to V, Coaxial   |
| 34WVF50              | W1 (male) to V (female) Adapter, W1 (1 mm) to V, Coaxial   |
| 34WVF50              | W1 (female) to V (male) Adapter, W1 (1 mm) to V, Coaxial   |
| 34WVF50              | W1 (female) to V (female) Adapter, W1 (1 mm) to V, Coaxial   |
| 33WW50               | W1 (male) to W1 (male) Adapter, W1 (1 mm) in-series, Coaxial   |
| 33WVF50              | W1 (male) to W1 (female) Adapter, W1 (1 mm) in-series, Coaxial   |
| 33WVF50              | W1 (female) to W1 (female) Adapter, W1 (1 mm) in-series, Coaxial   |
| 35WR10W              | WR10 to W1 (male) Adapter, W1 (1mm) to WR10 Waveguide  |
| 35WR10WF             | WR10 to W1 (female) Adapter, W1 (1mm) to WR10 Waveguide  |
| SC7260               | WR12 to W1 (male) Adapter, W1 (1 mm) to WR12 Waveguide   |
| SC7442               | WR12 to W1 (female) Adapter, W1 (1 mm) to WR12 Waveguide   |
| 35WR15V              | WR15 to V (male) Adapter, V (1.85mm) to WR15 Waveguide   |
| 35WR15VF             | WR15 to V (female) Adapter, V (1.85mm) to WR15 Waveguide   |
| For More Information | Refer to our <b>Precision RF &amp; Microwave Components Catalog</b> for descriptions of adapters and other components. |

**Miscellaneous Components**

|          |   |
|----------|---|
| 41W-3    | Attenuator, DC to 110 GHz, 0.2 W, 3 dB, W1(m) to W1(f), 50 Ω  |
| 41W-6    | Attenuator, DC to 110 GHz, 0.2 W, 6 dB, W1(m) to W1(f), 50 Ω  |
| 41W-10   | Attenuator, DC to 110 GHz, 0.2 W, 10 dB, W1(m) to W1(f), 50 Ω   |
| W240A    | Precision Power Divider, DC to 110 GHz, W1(f) input, W1(f) outputs, 3 resistor, 50 Ω                  |
| W241A    | Precision Power Splitter, DC to 110 GHz, W1(m) input, W1(f) outputs, 2 resistor, 50 Ω                 |
| MN25110A | Precision Directional Coupler, 20 GHz to 110 GHz, W1(f) input, W1(f) output, W1(f) coupled port, 50 Ω |

**Accessories**

- SC8215 Kelvin Bias Tee, low frequency limit: 70 kHz, Max Voltage: 16 VDC, Max Current: 100 mA
- SC7287 Kelvin Bias Tee, low frequency limit: 100 MHz, Max Voltage: 50 VDC, Max Current: 500 mA
- SC8218 Triax (male) to SMC (female) Cable, (Inner-shield floating at SMC end), 1.5 m (60 in) long  
two (2) needed per Kelvin Bias Tee
- SM6494 System floor console. Includes larger size writing table
- 2100-1-R GPIB cable, 1 m (39 in) long
- 2100-2-R GPIB cable, 2 m (79 in) long
- 2100-4-R GPIB cable, 4 m (157 in) long
- 806-206-R Flexible Coaxial Cable, DC to 70 GHz, 24 in (61 cm), V(m) – V(f), 50Ω  
for connecting the VNA and the 3743A Modules
- 806-209-R Flexible Coaxial Cable, DC to 70 GHz, 36 in (91.5 cm), V(m) – V(f), 50Ω  
for connecting the VNA and the 3743A Modules
- 01-201 Torque Wrench (for tightening male devices), 8 mm (5/16 in), 0.9 N·m (8 lbf·in)  
for SMA, 3.5 mm, 2.4 mm, K, and V connectors
- 01-202 Universal Test Port Connector Wrench
- 01-203 Torque Wrench (for tightening the VNA test ports to female devices)  
20.6 mm (13/16 in), 0.9 N·m (8 lbf·in)
- 01-204 Anritsu Stainless Steel Connector Wrench, circular, open-ended for SMA, 3.5 mm, 2.4 mm, K and  
V connectors
- 01-504 Torque wrench (for tightening male devices) 6 mm, 0.45 N·m (4 lbf·in) for 1.0 mm and 0.8 mm connectors
- 01-524 Low profile Torque Wrench (for tightening male devices), 6 mm, 0.45 N·m (4 lbf·in), 126 mm long for 1.0 mm  
and 0.8 mm connectors
- 01-529-R Torque Wrench, 4 mm (5/32 in), 0.17 N·m (1.5 lbf·in)  
(for tightening the test and reference IF connectors on the mmWave modules)