

PMX40 RF Power Meter



98408900B | Rev 20230830

PMX40 RF Power Meter – INSTRUCTION MANUAL

Revision 20230830

© Copyright 2023, by BOONTON Electronics, a subsidiary of the Wireless Telecom Group, Inc.
Parsippany, NJ, USA. All rights reserved.

P/N 98408900B

This manual covers the PMX40 RF Power Meter, serial numbers: 1001 and higher.

The PMX40 application software used in this product is licensed by Boonton Electronics, a subsidiary of the Wireless Telecom Group, Inc.

SAFETY SUMMARY

The following general safety precautions must be observed during all phases of operation and maintenance of this instrument. Failure to comply with these precautions or with specific warnings elsewhere in this manual violates safety standards of design, manufacture, and intended use of the instrument. Boonton Electronics assumes no liability for the customer's failure to comply with these requirements.

DO NOT OPERATE THE INSTRUMENT IN AN EXPLOSIVE ATMOSPHERE

Do not operate the instrument in the presence of flammable gases or fumes.

DO NOT OPERATE THE INSTRUMENT OUTSIDE

This instrument is designed for indoor use only.

KEEP AWAY FROM LIVE CIRCUITS

Operating personnel must not remove instrument covers. Component replacement and internal adjustments must be made by qualified maintenance personnel. Do not replace components with the power cable connected. Under certain conditions dangerous voltages may exist even though the power cable was removed, therefore; always disconnect power and discharge circuits before touching them.

DO NOT SERVICE OR ADJUST ALONE

Service and adjustments should be performed only by qualified service personnel. Do not attempt internal service or adjustment unless another person, capable of rendering first aid and resuscitation, is present.

DO NOT POSITION THE INSTRUMENT SO THAT IT IS DIFFICULT TO OPERATE THE DISCONNECTION DEVICE

The main power disconnection switch is located on the rear panel.

DO NOT SUBSTITUTE PARTS OR MODIFY INSTRUMENT

Do not install substitute parts or perform any unauthorized modifications on the instrument. Return the instrument to Boonton Electronics for repair to ensure that the safety features are maintained.

PMX40 RF Power Meter – INSTRUCTION MANUAL

SAFETY SYMBOLS



This safety requirement symbol has been adopted by the International Electro-technical Commission, Document 66 (Central Office) 3, Paragraph 5.3, which directs that an instrument be so labeled if, for the correct use of the instrument, it is necessary to refer to the instruction manual. In this case it is recommended that reference be made to the instruction manual when connecting the instrument to the signal source and USB host.



The CAUTION symbol denotes a hazard. It calls attention to an operational procedure, practice, or instruction that, if not followed, could result in damage to or destruction of part or all of the instrument and accessories. Do not proceed beyond a CAUTION symbol until its conditions are fully understood and met.



The NOTE symbol is used to mark information that should be read. This information can be very useful to the operator in dealing with the subjects covered in this section.



The HINT symbol is used to identify additional comments that are outside of the normal format of the manual and provide users additional information about the subject.

PMX40 RF Power Meter – INSTRUCTION MANUAL

Contents

1	General Information	1-1
1.1	Organization.....	1-1
1.2	Description.....	1-2
1.3	Features	1-2
1.4	Accessories.....	1-2
1.5	Optional Configurations.....	1-2
1.6	Specifications	1-2
2	Installation	2-1
2.1	Unpacking & Repacking	2-1
2.2	Power Requirements	2-2
2.3	Connections	2-2
2.4	Preliminary Check	2-3
3	Getting Started.....	3-1
3.1	Organization.....	3-1
3.2	Operating Controls, Indicators, and Connections.....	3-1
3.3	Touch Screen Display	3-4
3.4	Initialization.....	3-6
3.5	Making Measurements	3-8
3.5.1	Continuous Mode.....	3-8
3.5.2	Pulse Mode	3-9
3.5.3	Statistical Mode	3-10
4	Operation.....	4-1
4.1	Manual Operation.....	4-1
4.2	Control Menus	4-1
4.3	Parameter Data Entry and Selection.....	4-2
4.3.1	Numerical Data Entry.....	4-2
4.3.2	Parameter Pick-List Selection.....	4-2
4.4	Menu Reference.....	4-3
4.4.1	Main Menu.....	4-3
4.4.2	MAIN→Measure	4-3
4.4.3	MAIN→Display.....	4-4
4.4.4	MAIN→Stat. Mode	4-4
4.4.5	MAIN→Channel	4-5
4.4.6	MAIN→Time	4-8

PMX40 RF Power Meter – INSTRUCTION MANUAL

4.4.7	MAIN→Trigger	4-8
4.4.8	MAIN→Markers	4-9
4.4.9	MAIN→Pulse Def	4-10
4.4.10	MAIN→System	4-11
4.4.11	MAIN→System→Sensor Data	4-11
4.4.12	MAIN→System→I/O Config→LAN	4-12
4.4.13	MAIN→System→Test Source	4-12
4.4.14	MAIN→System→Exit	4-13
4.4.15	MAIN→System→Reports	4-13
5	Application Notes	5-1
5.1	Introduction to Pulse Measurements	5-1
5.1.1	5-1
5.1.2	Diode Detection	5-3
5.2	Pulse Definitions	5-4
5.2.1	Standard IEEE Pulse	5-5
5.3	Automatic Measurements	5-6
5.3.1	Automatic Measurement Criteria	5-6
5.3.2	Automatic Measurement Terms	5-6
5.3.3	Automatic Measurement Sequence	5-7
5.3.4	Average Power Over an Interval	5-10
5.4	Statistical Mode Automatic Measurements	5-11
5.5	Measurement Accuracy	5-13
6	Maintenance	6-1
6.1	Safety	6-1
6.2	Cleaning	6-1
6.3	Inspection	6-1
6.4	Lithium Battery	6-2
6.5	Software Upgrade	6-2
	Appendix A - Warranty and Repair Policy	APPENDIX A-1
	Appendix B - End User License Agreement	APPENDIX B-1

1 General Information

This instruction manual provides you with the information you need to install, operate, and maintain the Boonton PMX40 RF Power Meter. Section 1 is an introduction to the manual and the instrument.

1.1 Organization

The manual is organized into five sections and two Appendices, as follows:

Section 1 - General Information presents summary descriptions of the instrument and its principal features, accessories, and options.

Section 2 - Installation provides instructions for unpacking the instrument, setting it up for operation, connecting power and signal cables, and initial power-up.

Section 3 - Getting Started describes the controls and indicators and the initialization of operating parameters. Several practice exercises are provided to familiarize yourself with essential setup and control procedures.

Section 4 - Operation describes the display menus and procedures for operating the instrument locally from the front panel.

Section 5 - Application Notes provides supplementary information about PMX40 and sensor operation, advanced features, pulse measurement information, and measurement accuracy.

Appendix A - Warranty and Repair Policy states the policies governing the return and replacement of modules and instruments during and after the warranty period.

Appendix B - End User License Agreements

1.2 Description



The PMX40 RF Power Meter provides design engineers and technicians the utility of traditional benchtop instruments, the flexibility and performance of modern USB RF power sensors, and the simplicity of a multi-touch display built with Boonton award-winning technology.

As a benchtop meter, the PMX40 provides a standalone solution for capturing, displaying, and analyzing peak and average RF power in both the time and statistical domains through an intuitive, touch screen display.

The PMX40 RF Power Meter utilizes up to four Boonton USB RF power sensors with industry-leading performance and capabilities either independently or for synchronized multi-channel measurements of CW, modulated, and pulsed signals.

Providing the ultimate flexibility, the PMX40 sensors can be disconnected and independently used as standalone instruments.

1.3 Features

See PMX40 Datasheet for a brief description of key features.

1.4 Accessories

See PMX40 Datasheet for a complete list of accessories.

1.5 Optional Configurations

See PMX40 Datasheet for a complete list of optional configurations.

1.6 Specifications

See PMX40 Datasheet for the latest specifications.

2 Installation

This section contains unpacking and repacking instructions, power requirements, connection descriptions, and preliminary checkout procedures.

2.1 Unpacking & Repacking

The PMX40 RF Power Meter is shipped complete and is ready to use upon receipt. Figure 2-1 shows you the various pieces included in the packaging and the order in which they are loaded into the container. Actual details may vary from the illustration.

Note



Save the packing material and container to ship the instrument, if necessary. If the original materials (or suitable substitute) are not available, contact Boonton Electronics to purchase replacements. Store materials in a dry environment.

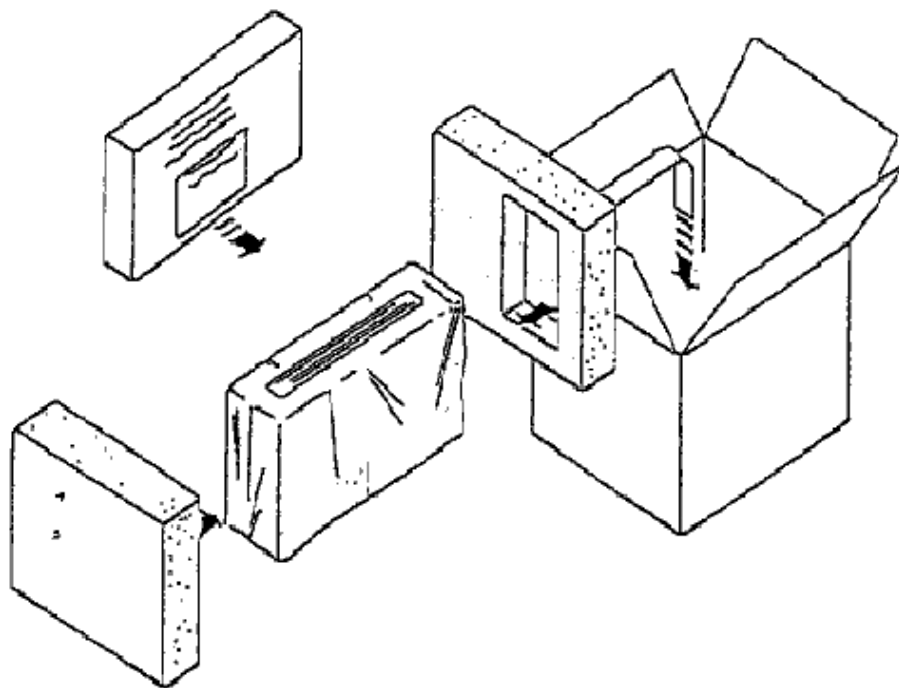

Figure 2-1. Packaging Diagram

Table 2-1. PMX40 RF Power Meter Packing List

PMX40 RF Power Meter

Line Cord

Information Card (describes where to download the latest manual, software, utilities)

For benchtop use, choose a clear, uncluttered area. Ensure that there is at least 2" of clearance at the fan air intake on the rear panel and the exhaust vents on the side panels. Pull-down feet are located on

the bottom of the instrument. Rack mounting instructions are provided with the optional rack mount kit.

2.2 Power Requirements

The PMX40 is equipped with a switching power supply that provides automatic operation from a 90 to 264 VAC, 47 to 63 Hz single-phase, AC power source. Maximum power consumption is 70 VA. Connect the power cord supplied with the instrument to the power receptacle on the rear panel. See Figure 3-2.

Caution



Before connecting the instrument to the power source, make certain that a 1.0-ampere time delay fuse (type T) is installed in the fuse holder on the rear panel.

Before removing the instrument cover for any reason, position the input module power switch to off (0 = OFF; 1 = ON) and disconnect the power cord.

2.3 Connections

Sensor(s)

Compatible sensors can be connected to any of the USB ports on the front or rear panel. However, the base PMX40 model only permits two sensors to be active at any one time. With the PMX40-4CH option, four sensors can be active at any one time. Sensors become active when plugged into a USB port or immediately if already plugged in when the PMX40 powers up.

Trigger

Most triggered applications can use the RF signal applied to the sensors for triggering. For measurements requiring external triggering, connect the external trigger signal to the Trig In BNC connector on the rear panel and connect a Sync cable from the Sync connector on the meter to the Multi I/O port on the sensor.

Note



The Sync cable must be connected to the Sync port corresponding to the USB port for the sensor Channel in use.

Remote

If the instrument is to be operated remotely using the GPIB (IEEE-488) bus, connect the instrument to the bus using the rear panel GPIB connector and appropriate cable. For Ethernet control, connect to the rear panel LAN connector. In most cases, it will be necessary to configure the interface using the System → I/O → Config menus.

2.4 Preliminary Check

The following preliminary check verifies that the instrument is operational and has the correct software installed. It should be performed before the instrument is placed into service. To perform the preliminary check, proceed as follows:

1. Press the lower half (marked "0") of the power switch in the center of the power module on the rear panel.
2. Connect the AC (mains) power cord to a suitable AC power source; 90 to 264 VAC, 47 to 63 Hz. The power supply will automatically adjust to voltages within this range.
3. Press the upper half (marked "1") of the power switch in the center of the power module on the rear panel, it will enter standby mode.
4. Press the ON/STBY key (marked with the international 0/1 on/standby symbol) on the front panel to turn the instrument on. The cooling fan and display backlight should turn on.
5. A bootup screen should appear that shows the boot status. After a self-check, the instrument will execute the application program. There will be some temporary dialogs indicating application initialization and channel updating. After several moments, a screen similar to Figure 2-2 should be displayed.



Figure 2-2. Typical Power-On Display

PMX40 RF Power Meter – INSTRUCTION MANUAL

Note



The base PMX40 model only permits two sensors to be active at any one time. With the PMX40-4CH option, four sensors can be active at any one time.

6. On the front panel, press the ● key to bring up the on-screen menu. From the Main menu, use the touch screen or the ◀, ▶, ▲, ▼, and ● keys on the front panel to browse to System→Reports→Configuration and select Show. A display similar to Figure 2-3 should appear.

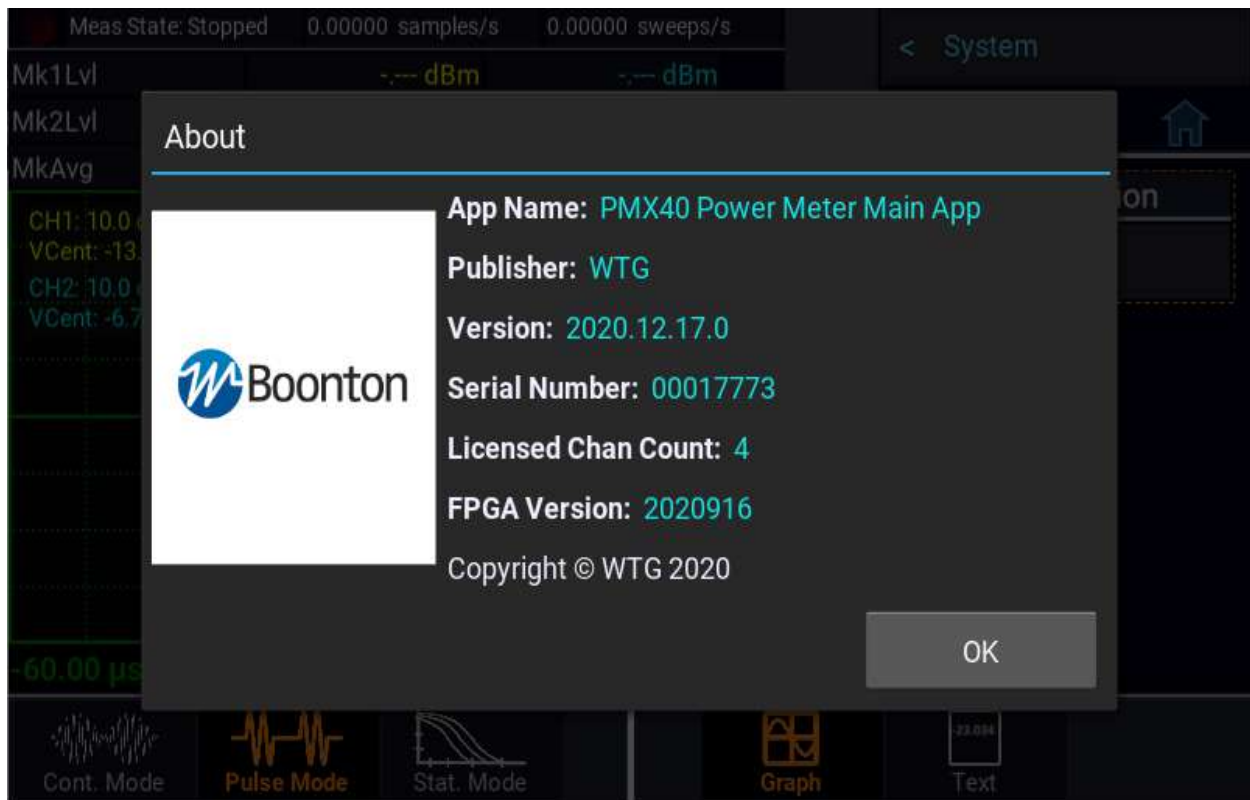

Figure 2-3. System > Configuration Report Display

7. Follow the steps in Section 3.4 to initialize the instrument.

3 Getting Started

This chapter will introduce the user to the PMX40 RF Power Meter. The chapter will identify objects on the front and rear panels, identify display organization, list the configuration of the instrument after initializing, and provide practice exercises for front panel operation. For additional information, see Section 4 "Operation."

3.1 Organization

Subsection 3.2 Operating Controls, Indicators, and Connections identifies the control features and connections on the front and rear panels.

Subsection 3.3 Touch Screen Display describes the data fields in the standard (graphic mode) display.

Subsection 3.4 Initialization explains how to turn the instrument on for the first time, connect a sensor, set the instrument up for operation, and initialize it to a known state. See Table 3-3 for initialized parameters and their values.

Subsection 3.5 Making Measurements describes the different measurement modes of the PMX40.

3.2 Operating Controls, Indicators, and Connections

Figures 3-1 and 3-2 illustrate the controls, indicators, and connectors on the front and rear panels, respectively, of the standard instrument. Refer to Table 3-1 for a description of each of the illustrated items. The function and operation of all controls, indicators, and connectors are the same on the standard and optional models.

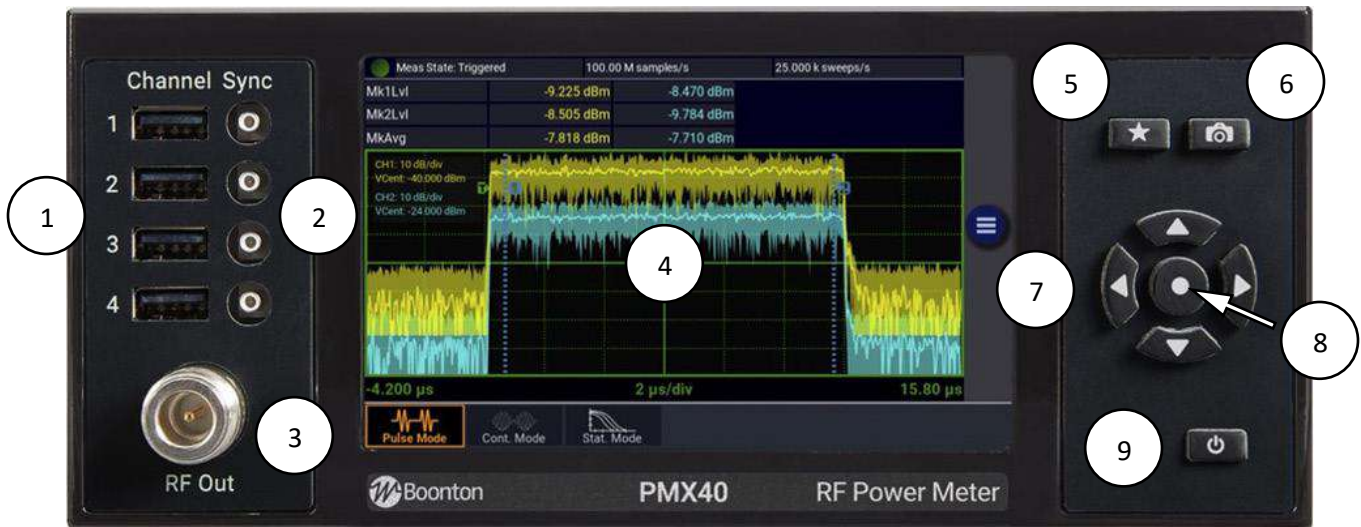



Figure 3-1. PMX40 RF Power Meter - Front Panel

PMX40 RF Power Meter – INSTRUCTION MANUAL

Table 3-1. Operating Controls, Indicators, and Connections

Reference #		Nomenclature	Function
Front	Rear		
1	1	Sensor Inputs	Four sensor inputs are located on the front and rear panels of the instrument. These are standard USB 2.0 Type A receptacles designed to accept only Boonton power sensors or standard USB keyboards, mice, and flash drives.
2	2	Trigger Inputs	Four sensor trigger inputs are located on the front and rear panels of the instrument. These are standard SMB receptacles designed to accept only Boonton power sensor trigger cables. Caution Do not attempt to connect anything other than Boonton power sensors and trigger cables! 
3	3	Test Source	The output of the built-in 50 MHz programmable test source is available from a Type-N connector located on the front, or optionally on the rear panel of the instrument. This test source is used to verify basic performance of sensors used with the PMX40.
4		Display Screen	Color touch screen display for the measurement and trigger channels, screen menus, status messages, text reports, and help screens.
5		★ Key	Favorites key. (This function is not fully implemented at this time). Enables the user to setup a customized menu to allow grouping frequently used menu items into one convenient menu.
6		 Key	Store image key saves a screen image of the meter to local storage. The images can be copied to an external USB storage device.
7		◀ and ▶ Keys	Used to assist navigating between items on the display and in the menus. Unless the user is in digit editing numeric entry mode.
7		▲ and ▼ Keys	Used for incrementing or decrementing numeric parameters, or scrolling through multi-line or multi-page displays.
8		● Key	Selects an on-screen item or menu and completes a numeric or picklist entry.
9		⏻ On/Standby Key	Toggles the instrument between “on” (fully powered) and “standby” (off, except for certain low-power internal circuits) modes. Entering standby mode will perform a save of the

PMX40 RF Power Meter – INSTRUCTION MANUAL

current instrument state before shutdown. Pressing and holding the On/Standby key for several seconds will force standby mode if the instrument has become non-responsive. In this case, no context save is performed.

10	Cooling Fan	Cooling air intake
11	GPIB	24-pin GPIB (IEEE-488) connector for connecting the power meter to the remote control General Purpose Instrument Bus. GPIB parameters can be configured through the menu.
12	AC Line Input	<p>A multi-function power input module is used to house the AC line input, main power switch, and safety fuse. The module accepts a standard AC line cord, included with the power meter. The power switch is used to shut off main instrument power. The safety fuse may also be accessed once the line cord is removed. The instrument's power supply accepts 90 to 264 VAC, so no line voltage selection switch is necessary.</p> <p>Caution Replace fuse only with specified type and rating: 1.0A-T (time delay type), 250 VAC.</p> 
13	HDMI	HDMI receptacle for connecting an external monitor to mirror front panel display. The image resolution will be 800 x 480 and will be stretched to fit the external full display size.
14	LAN Ethernet	LAN connector for remote control and firmware updates. Allows DHCP or fixed (IP / Subnet) setting mode. LAN parameters can be configured through the menu.
15	Trig In	BNC input for connecting an external trigger signal to the power meter. Voltage range is ± 5 volts, but the input impedance is 1 Megohm to allow use of common 10x oscilloscope probe for a ± 50 volt input range.
16	N/A	Reserved for potential future use.

PMX40 RF Power Meter – INSTRUCTION MANUAL



Figure 3-2. PMX40 RF Power Meter - Rear Panel

3.3 Touch Screen Display

The PMX40 RF Power Meter can be completely controlled through the touch screen display and by use of the front panel buttons. Table 3-2 describes the different areas of the display layout of the PMX40 RF Power Meter. Figure 3-3 shows the Graph Display mode of the instrument using the Pulse Measure mode with a menu exposed. Figure 3-4 shows the same measure mode with the menus hidden. The Text Display mode of the instrument provides a table view of measured parameters. Parameters depend on the Measure mode selected. See Section 4.4 for more information on the display format.

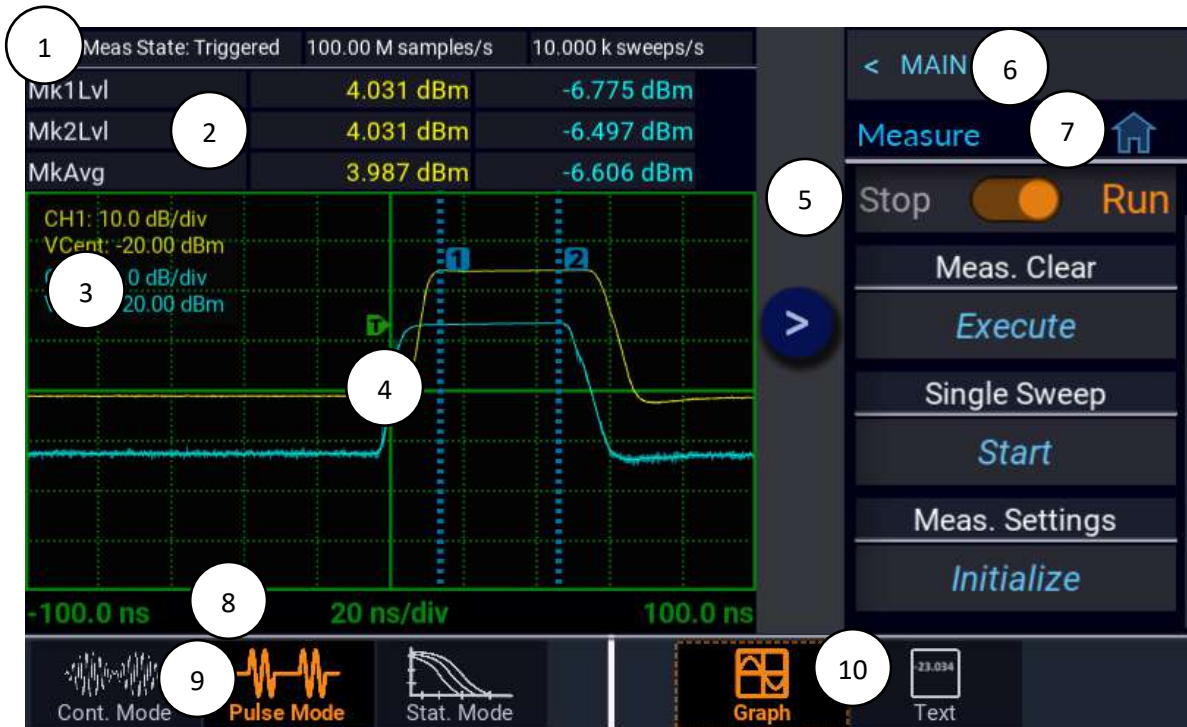





Figure 3-3. PMX40 Graph Display Using Pulse Measure Mode With Menus Exposed

PMX40 RF Power Meter – INSTRUCTION MANUAL

Table 3-2. Touch Screen Display Fields

Reference #	Field Name	Description
1	Status Bar	Indicates the measurement acquisition status of the unit. In Pulse mode, the sample rate and number of sweeps per second are also shown. In Statistical mode, it indicates the gating setting in use, run time, and number of points.
2	Parameters	Displays a table of measurements for each channel that is enabled on the meter. In Pulse and Continuous mode, measurements indicated are for power levels at each marker and the average power between the markers. For Statistical mode, the measurements are Average power, Maximum power, and Peak-to-Average Ratio or Crest Factor.
3	Channel Status	This area indicates which channels are ON and their individual scale and vertical center. <div style="display: flex; align-items: flex-start;"> <div style="margin-right: 10px;"> <p>Note</p>  </div> <p>The base PMX40 model only permits two sensors to be active at any one time. With the PMX40-4CH option, four sensors can be active at any one time.</p> </div>
4	Main Display	This area will show a plot when in Graph Display mode or a table of parameters when in Text Display mode for the measurement mode selected
5	Menu Bar	Select  to show and  to hide the on-screen menus.
6	Menu Path	Used to navigate the menu structure. Shows the menu that will be displayed when selected.
7	Current Menu/Home	Displays the name of the current menu and provides a home shortcut to the top-level Main menu. When in the Main or top-level menu, this field is not available.
8	Horizontal Scale	For Pulse and Continuous mode, indicates the time per division for the waveform display. In Statistical mode, the horizontal scale for the CCDF graph is in dB (dB relative).
9	Measure Mode	Indicates and allows selection of the current Measurement mode. Modes available are Continuous, Pulse, and Statistical.
10	Display Mode	Indicates and allows selection of the current Display mode in use. Modes available are Graph and Text. <div style="display: flex; align-items: flex-start;"> <div style="margin-right: 10px;"> <p>Hint</p>  </div> <p>The Graph Display mode for Continuous Measure mode will be a flat trace. It is best to use Text Display mode for continuous signal measurements.</p> </div>

PMX40 RF Power Meter – INSTRUCTION MANUAL

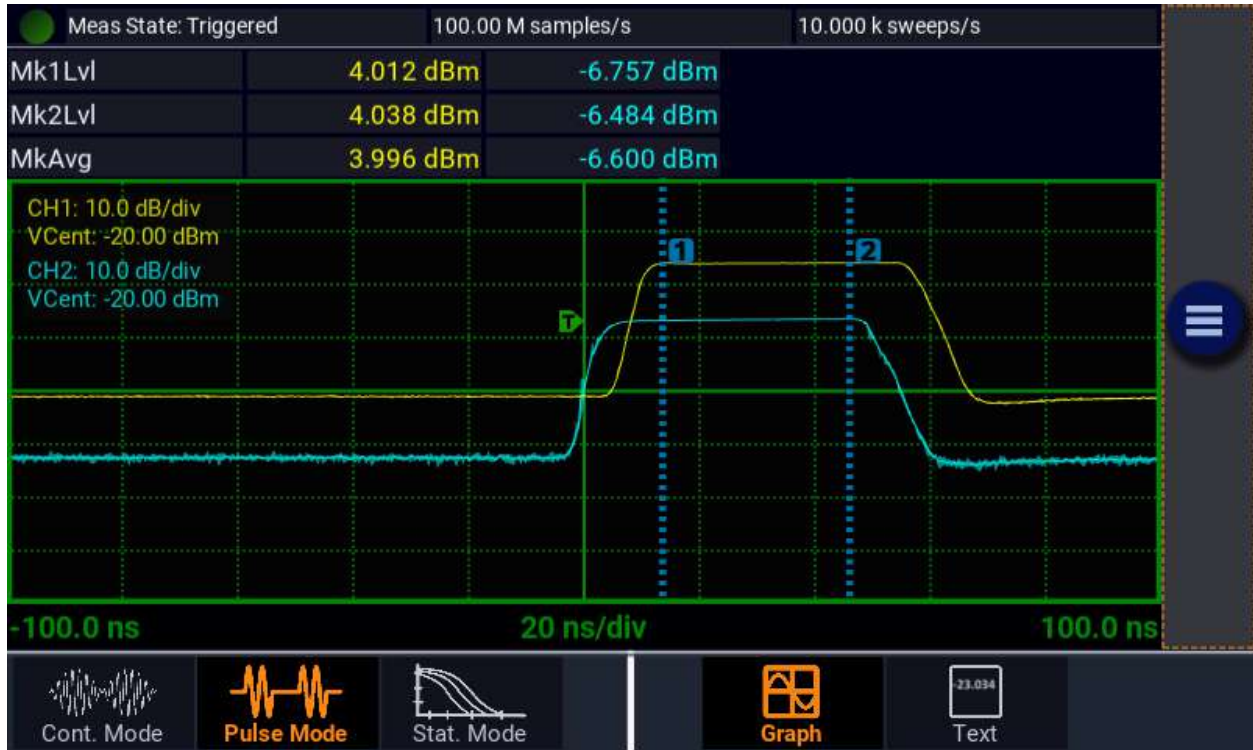

Figure 3-4. PMX40 Graph Display Using Pulse Measure Mode With Menus Hidden

3.4 Initialization

The steps shown here will initialize the PMX40 meter and prepare it for normal operations. Step 3 should only be performed when you wish to set the meter operations to a known state. This is typically done when you first power on the instrument or at the start of a new test.

STEP PROCEDURE

1. If the main power is off, press the power switch located on the rear panel. See Figure 3-2. Press the On/Standby key. See Figure 3-1. After a self-check, the instrument will execute the application program. There will be some momentary dialogs indicating application initialization and channel updating. After the last dialog the main screen will be on the display.

Caution



When selecting a sensor for an exercise or a measurement, be sure you know the power range of the sensor. Operation beyond the specified upper power limit may result in a permanent change of characteristics or burnout.

2. Connect the sensor USB cable to the Channel 1 input on the front or rear of the instrument. When the sensor is connected or disconnected, the instrument will momentarily show a channel update dialog.

PMX40 RF Power Meter – INSTRUCTION MANUAL

Note



Connecting the Sync cable from the Multi I/O port on the sensor to the corresponding Sync port on the instrument for the sensor in use is necessary if using an external trigger or when performing measurements across multiple channels.

- Use the ◀, ▶, ▲, ▼, and ● keys to navigate to and select or touch the  icon to show the menus. From the Main menu, select the Measure menu, navigate to the Meas. Settings, and select *Initialize*. This will load the default operating parameters listed in Table 3-3. This table only shows the parameters that are affected by initialization.

Table 3-3. Initialized Parameters

Parameter	Default
Measure Mode Select	Graph
<i><u>Parameters Related to the Measure Menu</u></i>	
Measurement	Run
<i><u>Parameters Related to the Display Menu</u></i>	
View	Graph
<i><u>Parameters Related to the Channel > Channel # > Menus</u></i>	
Channel1	On
Channel2	On
Channel3	On(4 CH option)
Channel4	On(4 CH option)
Vertical Scale	10 dB/Div
Vertical Center	-20.00 dBm
Averaging	8
Units	dBm
Video BW	HIGH
Peak Hold	OFF
dB Offset	0 dB
<i><u>Parameters Related to the Time Menu</u></i>	
Timebase	100 uS/div
Position	5.0 divisions
Trigger Delay	0.0 uS
<i><u>Parameters Related to the Trigger Menu</u></i>	
Holdoff	0 uS
Trigger Mode	AUTOPKPK
Trigger Slope	Positive
Trigger Source	CH1

PMX40 RF Power Meter – INSTRUCTION MANUAL

Parameters Related to the Markers Menu

Marker 1	-300 uS
Marker 2	300 uS

Parameters Related to the Pulse Def. > CH# Pulse Def > Menus

Distal	90%
Mesial	50%
Proximal	10%
Pulse Units	Watts
Start Gate	5.00%
End Gate	95%

Parameters Related to the Stat Mode Menu

Cursor Mode	Power
-------------	-------

3.5 Making Measurements

To perform accurate measurements, the following is a minimum list of things you should know about the signal that you wish to measure.

Signal Frequency - The center frequency of the carrier must be known to allow sensor frequency response compensation.

Modulation Bandwidth - If the signal is modulated, know the type of modulation and its bandwidth. Note that power sensors respond only to the amplitude modulation component of the modulation, and constant envelope modulation types such as FM can be considered a CW carrier for power measurement purposes.

3.5.1 Continuous Mode

Continuous mode is best for measuring repetitive signals. Since this mode performs a continuous measurement, it does not differentiate between the times a pulsed or periodic signal is off, and the times it is on. If you wish to make measurements that are synchronous with a period of a waveform, consider using Pulse mode instead.

Continuous mode is the best for the following types of measurement:

- Moderate signal level (above -40 dBm for Peak sensors and -60 dBm for CW sensors).
- Signal that is CW or continuously modulated with a modulation bandwidth that is less than the VBW of the sensor in use.
- Signal modulation may be periodic, but only non-synchronous measurements are needed (overall average and peak power).
- Noise-like digitally modulated signals such as CDMA and OFDM when only average measurements are needed.

PMX40 RF Power Meter – INSTRUCTION MANUAL

The measured result is the average power of the signal. Since the graphic display would basically just show a straight line, measurements in Continuous mode are best viewed using the Text Display mode.

Figure 3-5 shows a two-channel measurement displaying an average, minimum, and maximum power in Continuous mode.



Figure 3-5. PMX40 Text Display Mode Using Continuous Measure Mode

3.5.2 Pulse Mode

For periodic or pulsed signals, it is often necessary to analyze the power for a portion of the waveform, or a certain region of a pulse or pulse burst. For these applications, the PMX40 Series has a triggered Pulse mode.

The trigger signal can be either internal, triggered from a rising or falling edge on the measured signal; or external, triggered from a rear-panel BNC input. The trigger level and polarity are both programmable, as is the trigger delay time and trigger holdoff time. Displays of both pre- and post-trigger data are available, and an auto-trigger mode can be used to keep the trace running when no trigger edges are detected. An —auto peak-to-peak|| trigger level setting can be chosen to automatically set the trigger level based on the currently applied signal. The timebase can be set from 5 ns/div to 50 ms/div. The PMX40 graphical display has 10 horizontal and 8 vertical divisions. Vertical units can be set in dBm, Watts, and dB Volts. Setting vertical resolution does not affect the sensitivity of the instrument and is provided for ease of viewing.

Programmable markers can be moved to any portion of the trace that is visible on the screen, and these can be used to mark regions of interest for detailed power analysis. The instrument can display power at each marker, as well as average, minimum, and maximum power in the region between the two markers. This is very useful for examining the power during a TDMA or GSM burst when only the modulated portion in the center region of a timeslot is of interest. By adjusting trigger delay and other parameters, it is possible to measure the power of specific timeslots within the burst. Trigger holdoff allows burst synchronization even if there is more than one edge in the burst that may satisfy the trigger level. Simply set the holdoff time to slightly shorter than the burst's repetition interval to guarantee that triggering occurs at the same point in the burst each sweep. Figure 3-6 shows marker measurements for pulses on CH1 and CH2.

PMX40 RF Power Meter – INSTRUCTION MANUAL



Figure 3-6. Marker Measurements on CH1 and CH2 Pulses

Pulse mode is only available when using RTP Series power sensors and is the best choice for most pulse modulated and periodic signals. Pulse mode requires a repeating signal edge that can be used as a trigger, or an external trigger pulse that is synchronized with the modulation cycle. Pulse mode performs measurements that are synchronous with the trigger (that is the measurements are timed or gated) so that the same portion of the waveform is measured on each successive modulation cycle. Multiple modulation cycles may be averaged together, and measurement intervals may span both before and after the trigger. Pulse mode is best for the following types of measurements:

- Moderate signal level (above about -40 dBm except when modulation is off).
- The signal is periodic.
- A time snapshot of a single event is needed (minimum single-shot time is 200 nanoseconds).
- Typical modulation and signal types: LTE, 5G, RADAR, SatCom, TCAS, Bluetooth, Wireless LAN.

3.5.3 Statistical Mode

Certain modulated signals are completely random and provide no event that can serve as a trigger for measurements. CDMA or OFDM are common examples. The PMX40 Statistical mode was designed to provide measurements for these types of signals.

Statistical mode is only available when using peak power sensors with the PMX40. It is the best choice for analyzing signals with a high crest factor, that are noise-like with random or infrequent peaks, or are modulated in a random, non-periodic fashion. Statistical mode yields information about the *probability of occurrence* of various power levels without regard for *when* those power levels occurred. In the Statistical mode the instrument continuously samples the input signal and processes all of the samples to build power histograms. Many digitally modulated spread-spectrum formats use bandwidth coding techniques or many individual modulated carriers to distribute a source's digital information over a wide bandwidth, and temporally spread the data for improved robustness against interference. When these techniques are used, it is difficult to predict when peak signal levels will occur. Analysis of millions of data points gathered during a sustained measurement of several seconds or more can yield the statistical probabilities of each signal level with a high degree of confidence. Statistical mode is best for the following types of measurements:

PMX40 RF Power Meter – INSTRUCTION MANUAL

- Moderate signal level (above about -40 dBm except when modulation is off).
- Noise-like digitally modulated signals such as CDMA (and all its extensions) or OFDM when probability information is helpful in analyzing the signal.
- Any signal with random, infrequent peaks, when you need to know the peak-to-average ratio or Crest Factor and just *how infrequent* those peaks are.

Complementary Cumulative Distribution Function

The statistical analysis of the current sample population is displayed using a normalized Complementary Cumulative Distribution Function (CCDF) presentation shown in Figure 3-7. The CCDF is the probability of occurrence of a range of peak-to-average power ratios on a log-log scale. CCDF is non-increasing in y-axis and the maximum power sample lies at 0%. A cursor allows measurement of power or percentage at a user-defined point on the CCDF. As with all other graphical displays, the trace can be easily scaled and zoomed, or the statistical data may be presented as a table in Text Display mode.



Figure 3-7. CCDF Plot

The CCDF has become a useful tool for analyzing communication signals that have a Gaussian-like distribution (CDMA, OFDM) where signal compression can be observed at rarely occurring peaks. It is most often presented graphically using a log-log format where the x-axis represents the relative offset in dB from the average power level and the log-scaled y-axis is the percent probability that power will exceed the x-axis value.

In a non-statistical peak power measurement, the peak-to-average ratio is the parameter that describes the headroom required in linear amplifiers to prevent clipping or compressing the modulated carrier. The meaning of this ratio is easy to visualize in the case of simple modulation in which there is close correspondence between the modulating waveform and the carrier envelope. When this correspondence is not present, the peak-to-average ratio alone does not provide adequate information. It is necessary to know what fraction of time the power is above (or below) particular levels. For example, some digital modulation schemes produce narrow and relatively infrequent power peaks that can be compressed with minimal effect. The peak-to-average ratio alone would not reveal anything about the fractional time occurrence of the peaks, but the CCDF clearly shows this information. In Figure 3-8, assume a full length run of one hour plus has been made and the CCDF is analyzed. At 0% is the maximum peak power that occurred during the entire run. At 1% is the power level that was exceeded only 1% of the time during the entire run.

PMX40 RF Power Meter – INSTRUCTION MANUAL



Figure 3-8. CCDF Plot With Menu Showing Cursor at 1%

Note that this analysis does not depend upon any particular test signal, or upon synchronization with the modulating signal. In fact, the analysis can be done using actual communication system signals. Normal operation is not disturbed by the need to inject special test signals. This type of analysis is particularly suited to the situation in which the bit error rate (BER) or some other error rate measure is correlated with the percentage of time that the signal is corrupted. If known short intervals of clipping are tolerable, the CCDF can be used to determine optimum transmitter power output. The CCDF is also used to evaluate various modulation schemes to determine the demands that will be made on linear amplifiers and transmitters and the sensitivity to non-linear behavior.

4 Operation

This section presents the control menus and procedures for operating the PMX40 in the manual mode. All the display menus that control the instrument are illustrated and accompanied by instructions for using each menu item.

4.1 Manual Operation

In the manual mode, the instrument is controlled from the front panel by selecting items from a system of displayed menus. To properly input commands and data using these menus, you should be familiar with the menu conventions described in the next section.

4.2 Control Menus

The menus that control the PMX40 RF Power Meter are accessed from the top-level MAIN menu. Display the MAIN menu by selecting the  icon on the display. The MAIN menu structure for Pulse mode operations is illustrated in Figure 4-1.

Menus and parameters may be selected by using the front panel ◀, ▶, ▲, ▼ keys to browse and using the ● key to select the entry or by use of the touch screen.

The PMX40 RF Power Meter base model only permits two sensors to be active at any one time. With the PMX40-4CH option, four sensors can be active at any one time. In the Menu Reference that follows the designation "Channel#" is used to mean that all active channels have menus of this structure type except for different colorization.

Some menus have mode-dependent properties. Typically, one or more menu boxes in a submenu may change as the measurement mode is changed from Continuous to Pulse to Statistical. In the Menu Reference that follows these menus are indicated for mode dependency.

Menus with more selections than what fits on the display can be scrolled with the touch screen or front panel buttons.



Figure 4-1. Pulse Mode Main Menu

4.3 Parameter Data Entry and Selection

The PMX40 RF Power Meter parameters can be changed in various ways depending on the type of parameter being addressed.

4.3.1 Numerical Data Entry

Numerical data can be incremented/decremented by selecting the “+” and “-” icons with the front panel keys or by touching them. Selecting the numeric setting brings up an on-screen numeric keypad similar to the one shown in Figure 4-2.



Figure 4-2. Channel 1 Vertical Center Numeric Keypad

4.3.2 Parameter Pick-List Selection

Some parameters use a menu or pick-list of settings to choose from. The Trigger source setting seen in Figure 4-3 is an example of a pick-list. Use the arrow up and down icons to cycle through the settings or select the value to bring up the pick-list to choose from.



Figure 4-3. Trigger Source Pick-List

4.4 Menu Reference

4.4.1 Main Menu

The Main Menu shown in Figure 4-4 is the topmost menu level from which all other menus originate.

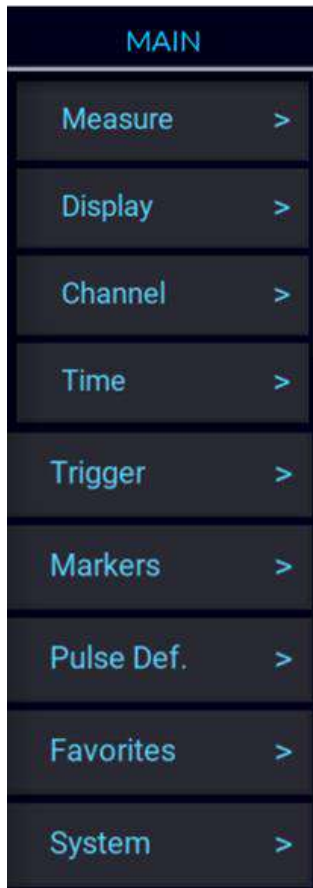
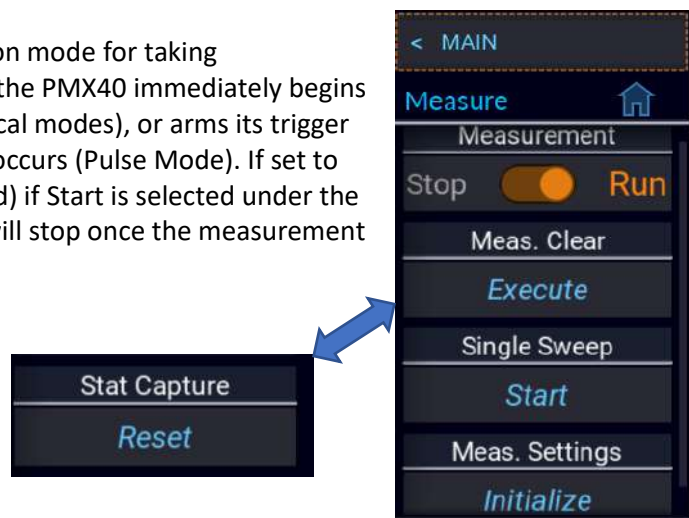

Figure 4-4. The MAIN Menu

4.4.2 MAIN → Measure

Measurement: The state of the data acquisition mode for taking measurements. If Measurement is set to Run, the PMX40 immediately begins taking measurements (Continuous and Statistical modes), or arms its trigger and takes a measurement each time a trigger occurs (Pulse Mode). If set to Stop, the measurement will begin (or be armed) if Start is selected under the Single Sweep setting (Pulse Mode Only), and will stop once the measurement criteria (averaging) has been satisfied.

Meas. Clear: Selecting Execute clears display traces, data buffers, and clears averaging filters to empty. In Statistical Measure mode, the menu item is replaced with Stat Capture and selecting Reset clears the acquired sample population.



PMX40 RF Power Meter – INSTRUCTION MANUAL

Single Sweep: Only available in Pulse mode. Select to start a single measurement cycle in Pulse mode when Measurement is set to Stop. Enough trace sweeps must be triggered to satisfy the channel averaging setting.

Meas. Settings: This will load the default operating parameters listed in Table 3-3 into the meter. Only the settings shown in the table are affected and all others remain in their current state.

4.4.3 MAIN→Display

View: Selecting Text displays a table of measurements for the current measurement mode. In Continuous mode, selecting Text displays the enabled channel power as shown in Figure 3-5. Selecting Graph displays the trace graphical view.

Envelope: Enables or disables the Envelope display mode. In Pulse and Modulated modes, the Envelope display is used to highlight the range of signal excursions. When Envelope display mode is On, the trace is drawn as a wide line, which is filled in between the minimum and maximum power readings. A series of vertical pixels, representing the range of signal excursions or "envelope" of the signal will be illuminated for each horizontal trace pixel. Envelope display is only available for Peak Power sensors.

Key Beep: Enables and disables the audible key beep.



4.4.4 MAIN→Stat. Mode

Cursor Pct: Sets the CCDF cursor to the desired probability. When Cursor mode is set to Power, the menu item changes to Cur Pow Ref and sets the desired power.

Cursor Mode: Select the independent variable for the CCDF cursor. If Percent is selected, relative power at the cursor's intersection with the CCDF curve will be measured. If Power is selected, probability at the cursor's intersection with the CCDF curve will be measured.

Horiz Scale: Select the horizontal scale for the statistical graphic display.

Horiz Offset: Select the horizontal offset for statistical graphic display.

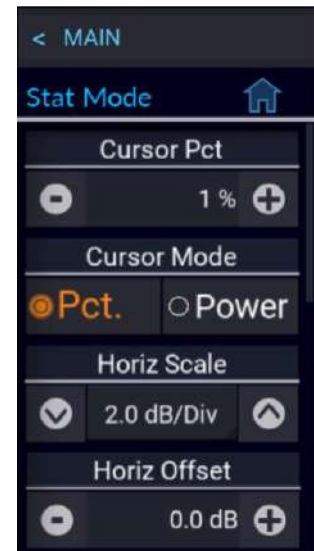

PMX40 RF Power Meter – INSTRUCTION MANUAL

Stat. Gating: Selects Freerun or Marker gating for statistical acquisition. If Freerun is selected, then all the samples are acquired without regard to sweep acquisition. If Markers are selected, then only samples within the time marker interval on the Pulse mode triggered sweep will be included in the statistical sample population.

Term Count: Sets the terminal sample count for the CCDF acquisition.

Term Time: Sets the terminal running time for the CCDF acquisition.

Term Action: Select the action to take when either the terminal count is reached or terminal time has elapsed. Selecting Decimate will divide all sample bins by 2 and continue. The total sample count will be halved each time a decimation occurs. Selecting Restart clears the statistical sample population and starts a new one. Selecting Stop will stop accumulating samples and hold the result.

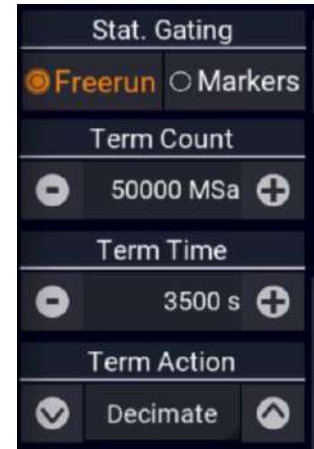

4.4.5 MAIN→Channel

Channel#: Opens the settings menu for the selected channel.

Note The base PMX40 model only permits two sensors to be active at any one time. With the PMX40-4CH option, four sensors can be active at any one time.

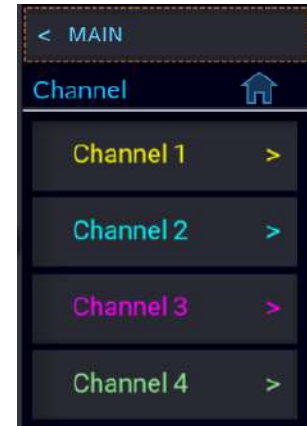

MAIN→Channel→Channel#

Chan. Enabled: Toggles display of the trace and measurements for the channel. The channel may still be used as a trigger source when set to Off.

Vert Scale: Set the power or voltage vertical axis level for the trace display based on the units as shown in Table 4-1.

Units	Scale
dBm	0.1, 0.2, 0.5 1, 2, 5, 10, 20, 50 dB/div
Watts	1 pW to 500 MW/div in a 1-2-5 progression
Volts	1 μV to 100 kV/ div in a 1-2-5 progression

Table 4-1. Vertical Scale Range for Units Selected



Vert Center: Set the power or voltage level of the horizontal centerline of the graph for the specified channel in the selected channel units.

PMX40 RF Power Meter – INSTRUCTION MANUAL

Averaging: Only available in Pulse and Statistical modes. Set the number of traces averaged together to form the measurement result on the selected channel. Averaging can be used to reduce display noise on both the visible trace, and on marker and automatic pulse measurements. Trace averaging is a continuous process in which the measurement points from each sweep are weighted (multiplied) by an appropriate factor and averaged into the existing trace data points. In this way, the most recent data will always have the greatest effect on the trace waveform, and older measurements will be decayed at a rate determined by the averaging setting and trigger rate. This averaging technique is often referred to as “exponential” averaging because averaging imposes a first-order Infinite Impulse Response (IIR) exponential filter with a time constant of "n" where n is the Average (number of averages) setting.

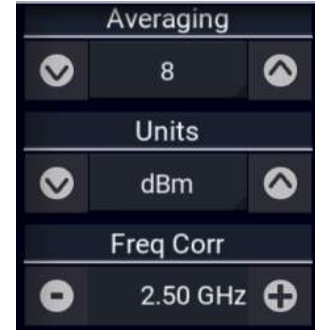

Note



For timebase settings of 200 ns/div and faster, the RTP Series sensors acquire samples using a technique called equivalent time or random interleaved sampling (RIS). In this mode, not every pixel on the trace gets updated on each sweep, and the total number of sweeps needed to satisfy the average setting will be increased by the sample interleave ratio of that particular timebase. At all times the average trace is the average of all samples for each pixel, and the min/max are the lowest and highest of that same block of samples for each pixel.

Units:

Select the channel units. The trace may be shown in units of dBm, Watts, or Volts. The Units selection determines the range of the scale values and also affects displayed text and measurement values.

Freq. Corr:

Sets measurement frequency for the RF signal that is applied to the sensor for the current measurement. The appropriate frequency calibration factor from the sensor’s calibration table will be interpolated and applied automatically. Application of this calibration factor compensates for the effect of variations in the flatness of the sensor’s frequency response.

Note



The power sensor has no way to determine the carrier frequency of the applied signal, so the user must always enter the frequency.

Filter State:

Available in Continuous mode only. Set the current value of the integration filter on the selected channel. The filter can be set to Off, On, or Auto. Off, provides no filtering, and can be used at high signal levels when absolute minimum settling time is required. On, allows a user-specified integration time to be entered for use. Auto, uses a variable amount of filtering, which is set automatically by the power meter based on the current signal level to a value that gives a good compromise between measurement noise and settling time at most levels.

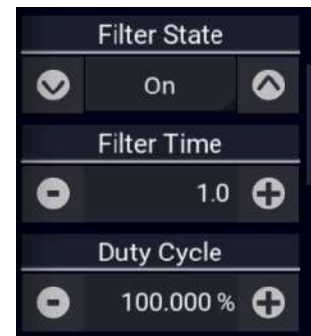

PMX40 RF Power Meter – INSTRUCTION MANUAL

Filter Time: Available in Continuous mode only. Sets the length of the integration filter. The filter is a “sliding window” which averages samples taken within a time window whose duration is set by this field. All samples within the time window are equally weighted.

Duty Cycle: Available in Continuous mode only. Sets the duty cycle in percent for calculated CW pulse power measurements. Setting the duty cycle to 100% is equivalent to a CW measurement.

Video BW: Sets the sensor video bandwidth for the channel. HIGH is appropriate for most measurements, and the actual bandwidth depends upon the sensor model. LOW bandwidth offers additional noise reduction for CW or signals with very low modulation bandwidth. If LOW bandwidth is used on signals with fast modulation, measurement errors may result if the sensor cannot track the fast-changing envelope of the signal.

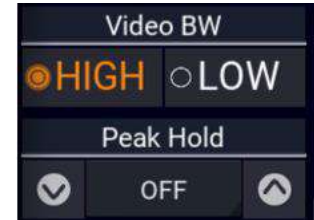

Peak Hold: Set the operating mode of the selected channel’s peak hold function. When set to OFF, peak values are not held. When set to instantaneous (INST) instantaneous peak readings are held until reset by a new acquisition or cleared manually. This setting is used when it is desirable to hold the highest peak over a long measurement interval without any decay. When set to average (AVG) peak readings are held for a short time, and then decayed towards the average power at a rate proportional to the Averaging setting. This is the best setting for most signals, because the peak will always represent the peak power of the current signal, and the resulting peak-to-average ratio will be correct shortly after any signal level changes.

dB Offset: Sets a measurement offset in dB for the selected channel. This is used to compensate for external couplers, attenuators, or amplifiers in the RF signal path ahead of the power sensor.

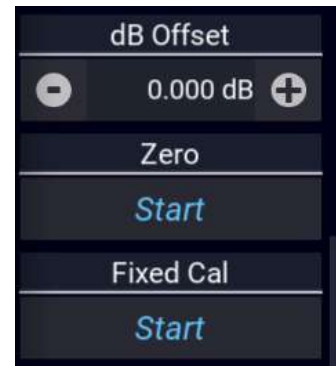

Zero: Performs a zero offset null adjustment. The sensor does not need to be connected to any calibrator for zeroing. This action removes the effect of small, residual power offsets, and should be performed prior to low-level measurements. The procedure is often performed in-system. There should be no RF signal applied to the sensor input prior to zeroing.

Fixed Cal: Performs a single point sensor gain calibration of the selected channel at 0 dBm and the current frequency setting. This requires a calibrated 0 dBm (1.00 mW) signal source at the current measurement frequency. This procedure calibrates the sensor’s gain at a single point. At other levels, that gain setting is combined with stored linearity factors to compute the actual power.

Caution



The built-in test source of the PMX40 is not a sufficiently calibrated source for performing a fixed calibration. An **external** calibration source is required. Note that fixed calibration is NOT REQUIRED for USB power sensors.

4.4.6 MAIN→Time

Timebase: Controls the timebase or horizontal scale of the acquisition and is noted on the horizontal axis label of the Trace View. The Timebase pulldown menu permits selection of fixed timebase ranges from 5 ns/div to 50 ms/div (sensor series dependent) in a 1-2-5 progression.

Position: Sets the location of the trigger point on the acquired trace waveform. The Trig Delay setting is in addition to this setting, and will cause the trigger position to appear in a different location.

Trig Delay: The trigger delay time is set in seconds with respect to the trigger. Positive values mean that the trace display shows a time interval after the trigger event. This positions the trigger event to the left of the trigger point on the display, and is useful for viewing events during a pulse, or some fixed delay time after the rising edge trigger. Negative trigger delay mean that the trace display shows a time interval before the trigger event, and is useful for looking at events preceding the trigger edge.

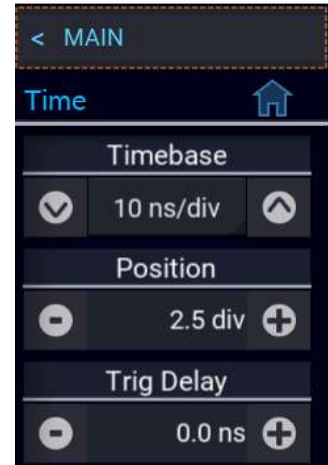

4.4.7 MAIN→Trigger

Trigger Holdoff: Set the trigger holdoff time. Trigger holdoff is used to disable the trigger for a specified amount of time after each trigger event. The holdoff time starts immediately after each valid trigger edge and will not permit any new triggers until the time has expired. When the holdoff time is up, the trigger re-arms, and the next valid trigger event (edge) will cause a new sweep. This feature is used to help synchronize the power meter with burst waveforms such as a TDMA or GSM frame. The trigger holdoff resolution is 0.01 microseconds, and it should be set to a time that is longer than the burst duration but shorter than the frame repetition interval.

Trigger Level: Sets the threshold level for the trigger signal used in the Auto and Normal trigger modes. The trigger level can be entered numerically or changed by using arrow keys. The trigger level range has a range that is sensor model dependent (see the sensor specifications for your specific sensor model).

The trigger range is automatically adjusted to include the dB Offset parameter set for the source channel. For example, if the trigger level = 10 dBm and the dB Offset is changed from 0 to 20 dB, then the offset-adjusted trigger level will be displayed to the user as 30 dBm. Likewise, the maximum trigger level range will be extended to 40 dBm. The trigger level set point and setting range are both shifted upward by 20 dB.

PMX40 RF Power Meter – INSTRUCTION MANUAL

Trigger Mode: Set the trigger mode for synchronizing data acquisition with pulsed signals. Normal mode will cause a sweep to be triggered each time the power level crosses the preset trigger level in the direction specified by the trigger slope setting. If there are no edges that cross this level, no data acquisition will occur. Auto mode operates in much the same way as Normal mode but will automatically generate a trace if no trigger edges are detected for a period of time (100 to 500 milliseconds, depending upon timebase). This will keep the trace updating even if the pulse edges stop. The Auto PK-PK mode operates the same as Auto mode but will adjust the trigger level to halfway between the highest and lowest power or voltage levels detected. This aids in maintaining synchronization with a pulse signal of varying level. The Freerun mode forces unsynchronized traces at a high rate to assist in locating the signal.

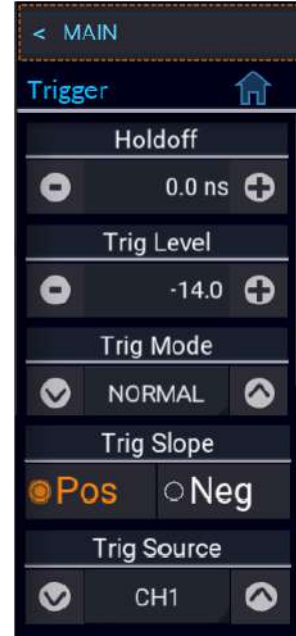

Trigger Source: Set the trigger source used for synchronizing data acquisition. The CH # settings use the signal from the associated sensor. Ext setting uses the signal applied to the rear panel TRIG IN connector.

The trigger source can be any of the resource channels (CH1, CH2, etc.), or the Ext(ernal) trigger input signal. The Ind(ependent) trigger setting allows each connected sensor to trigger independently from its own RF input.

The external trigger is attached to the Trig In BNC connector on the rear of the PMX40 Power Meter and requires a TTL signal level, minimum pulse width of 10 ns, and maximum frequency of 50 MHz.

Note Connecting the Sync cable from the Multi I/O port on the sensor to the corresponding Sync port on the instrument for the sensor in use is necessary if using an external trigger or when performing measurements across multiple channels.



Trigger Slope: Set the trigger slope or polarity. When set to +, trigger events will be generated when a signal's rising edge crosses the trigger level threshold. When – is selected, trigger events are generated on the falling edge of the pulse.

4.4.8 MAIN → Markers

Marker #: Set the time position of marker 1 or 2 relative to the trigger. Note that time markers must be positioned within the time limits of the trace window in the graph display. If a time outside of the display limits is entered, the marker will be placed at the first or last time position as appropriate.

Δ Time: Displays the result of Marker 2 - 1 in seconds. This item is read only.

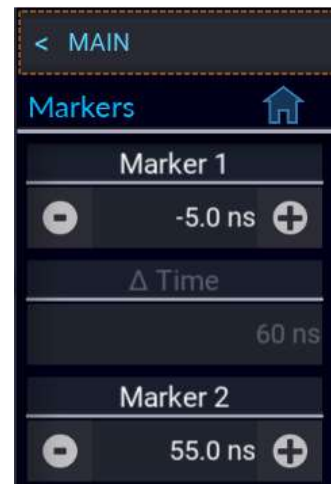

4.4.9 MAIN→Pulse Def

CH# Pulse Def: Opens the Pulse Definition menu for the selected channel.

MAIN→Pulse Def→CH# Pulse Def

Distal: Sets the pulse amplitude percentage that defines the end of a rising edge or beginning of a falling edge transition. Typically, this is 90% voltage or 81% power relative to the top level of the pulse. This setting is used when making automatic pulse risetime and falltime calculations.

Mesial: Sets the pulse amplitude percentage that defines the midpoint of a rising or falling edge transition. Typically, this is 50% voltage or 25% power relative to the top level of the pulse. This setting is used when making automatic pulse width and duty cycle calculations.

Proximal: Sets the pulse amplitude percentage that defines the beginning of a rising edge or end of a falling edge transition. Typically, this is 10% voltage or 1% power relative to the top level of the pulse. This setting is used when making automatic pulse risetime and falltime calculations.

Pulse Units: Controls whether the distal, mesial, and proximal thresholds are computed as voltage or power percentages of the top/bottom amplitudes. If Volts is selected, the pulse transition thresholds are computed as voltage percentages, and if Watts, they are computed as power percentages.

Many pulse measurements call for 10% to 90% voltage (which equates to 1% to 81% power) for risetime and falltime measurements, and measure pulse widths from the half-power (-3 dB, 50% power, or 71% voltage) points. The Pulse Units setting is independent of the channel’s display units setting.

Start Gate: Sets the beginning of the pulse measurement region as a percentage of the pulse width. The Start Gate has a continuous range of 0.0% to 40.0% of the pulse width and may be entered numerically or varied using the up or down arrows.

End Gate: Sets the end of the pulse measurement region as a percentage of the pulse width. The End Gate has a continuous range of 60.0% to 100.0% of the pulse width and may be entered numerically or varied using the up or down arrows.

The Gate settings define the measurement interval for the following power related pulse measurements: Pulse Average, Pulse Peak, Pulse Minimum, and Pulse Droop/Tilt. Pulse timing

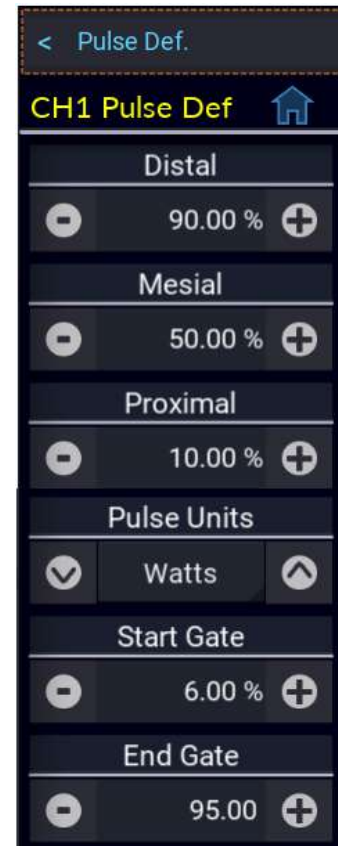

PMX40 RF Power Meter – INSTRUCTION MANUAL

measurements between mesial crossings such as width and period are not affected. The purpose of the Pulse Gate setting is to exclude edge transition effects from the pulse power measurements.

4.4.10 MAIN→System

The System menu displays the available system-level features and functionality.



4.4.11 MAIN→System→Sensor Data

Sensor # Info: Provides information about the selected sensor in a pop-up dialog like Figure 4-5.

A screenshot of the CH1 Information dialog. It has a title 'CH1 Information' and a table with columns: Sensor, Hardware, Hi BW Cal Fact, and Lo BW Cal Fact. The data rows are: Model (55006), Serial Number (8908), Firmware (20200406), FPGA (20191002), Manufactured Date (20181107), Factory Cal Date (20181129), Maximum Power (dBm) (20.0), and Minimum Power (dBm) (-60.0). There is an 'Exit' button at the bottom.

Sensor	Hardware	Hi BW Cal Fact	Lo BW Cal Fact
Model	55006		
Serial Number	8908		
Firmware	20200406		
FPGA	20191002		
Manufactured Date	20181107		
Factory Cal Date	20181129		
Maximum Power (dBm)	20.0		
Minimum Power (dBm)	-60.0		

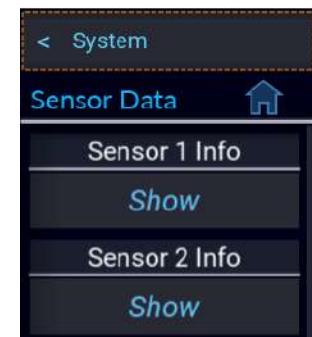

Figure 4-5. CH# Information Dialog

PMX40 RF Power Meter – INSTRUCTION MANUAL

MAIN→System→I/O Config

GPIB Address: Set and View the current GPIB address in use for instruments equipped with GPIB option.



4.4.12 MAIN→System→I/O Config→LAN

DHCP/AutoIP: Set the state of DHCP/AutoIP system for the Ethernet port.

If DHCP/AutoIP is enabled (On), the instrument will attempt to obtain its IP Address and Subnet Mask, a DHCP (dynamic host configuration protocol) server on the network. If no DHCP server is found, the instrument will select its own IP Address and Subnet Mask values using the AutoIP protocol.

If DHCP/AutoIP is disabled (Off), the instrument will use the IP Address and Subnet Mask values that have been set by the user.

IP Address: Set the Internet Protocol (IP) address of the Ethernet adapter. If DHCP/AutoIP mode is enabled, this menu is read-only.

Subnet Mask: Set the subnet mask for the Ethernet adapter. If DHCP/AutoIP mode is enabled, this menu is read-only.

MAC Address: Displays the MAC address for the Ethernet adapter. This menu item is read-only.

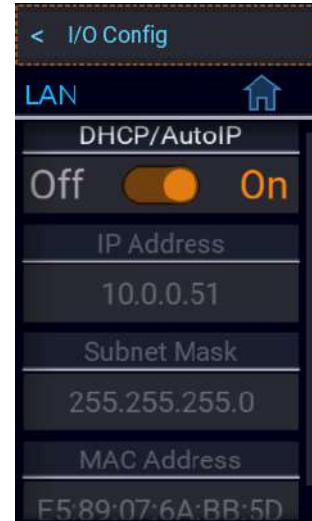

4.4.13 MAIN→System→Test Source

Test Source: Enable or Disable the output of the built-in 0 dBm 50 MHz test source.

Caution



The built-in test source of the PMX40 is not a sufficiently calibrated source for performing a fixed calibration. An **external** calibration source is required.

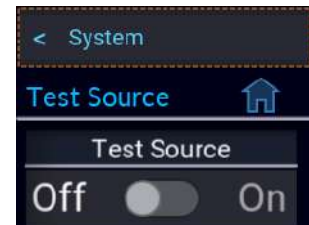

4.4.14 MAIN→System→Exit

Exit To Desktop: Exits the PMX40 Power Meter Main application and allows access to OS Desktop.

Shut Down: Shuts down power to the PMX40 putting the meter in standby mode and is the same as pressing the ON/Standby button on the front panel.



4.4.15 MAIN→System→Reports

Configuration: Select Show to display an About dialog with configuration information for the PMX40 Power Meter like that shown in Figure 2-3.



Update Software: Select Go to search the connected USB drive for the *.tar software update file and update or re-install the version found. If no valid file is found, the dialog in Figure 4-6 appears and the PMX40 does nothing.

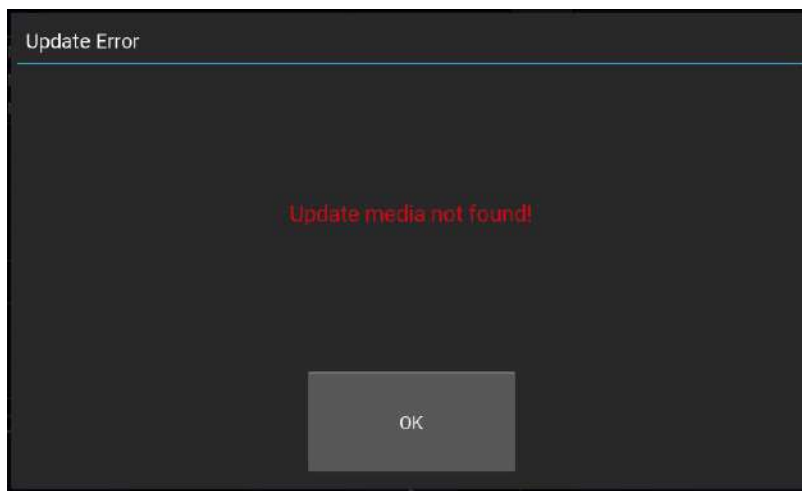

Figure 4-6. Update Error Dialog

5 Application Notes

This section provides supplementary material to enhance your knowledge of Model PMX40 operation, advanced features, and measurement accuracy. Topics covered in this section include pulse measurement fundamentals, automatic measurement principles, and an analysis of measurement accuracy.

5.1 Introduction to Pulse Measurements

5.1.1 Measurement Fundamentals

The following is a brief review of power measurement fundamentals.

Unmodulated Carrier Power. The average power of an unmodulated carrier consisting of a continuous, constant amplitude sinewave signal is also termed continuous wave (CW) power. For a known value of load impedance R , and applied voltage V_{rms} , the average power is:

$$P = V_{rms}^2/R \quad \text{watts}$$

Power meters designed to measure CW power can use thermoelectric-based sensors which respond to the heating effect of the signal or diode detectors which respond to the voltage of the signal. With careful calibration accurate measurements can be obtained over a wide range of input power levels.

Modulated Carrier Power. The average power of a modulated carrier which has varying amplitude can be measured accurately by a CW type power meter with a thermoelectric detector, but the lack of sensitivity will limit the range. Diode detectors can be used at low power, square-law response levels. At higher power levels the diode responds in a more linear manner and significant error results.

Pulse Power. Pulse power refers to power measured during the on time of pulsed RF signals (Figure 5-1). Traditionally, these signals have been measured in two steps: (1) thermoelectric sensors measure the average signal power, (2) the reading is then divided by the duty cycle to obtain pulse power, P_{pulse} :

$$P_{pulse} = \text{Average Power} / \text{Duty Cycle, where Duty Cycle} = \text{Pulse Width} / \text{Pulse Period}$$

Pulse power provides useful results when applied to rectangular pulses, but is inaccurate for pulse shapes that include distortions, such as overshoot or droop (Figure 5-2).

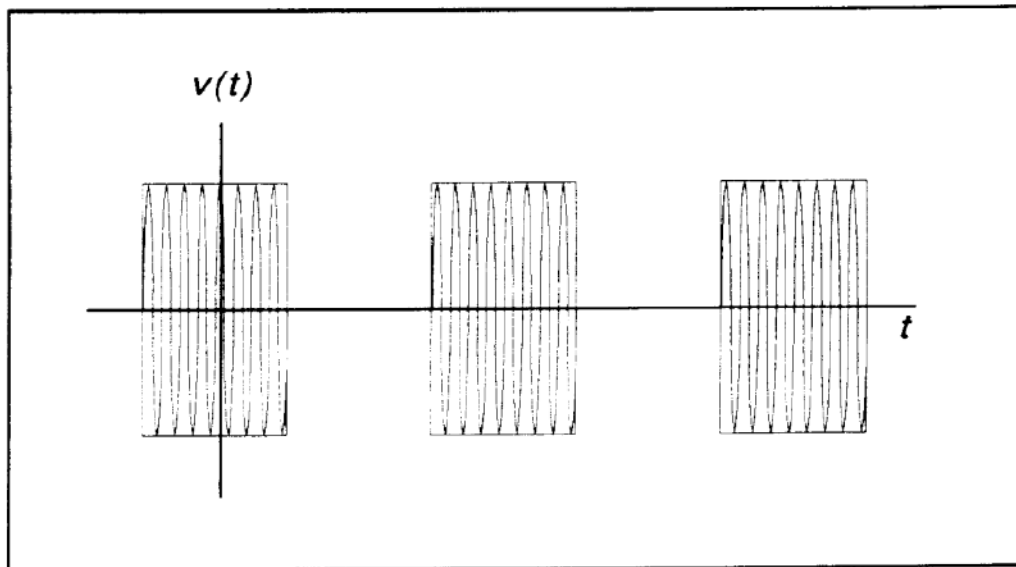

Figure 5-1. Pulsed RF Signal

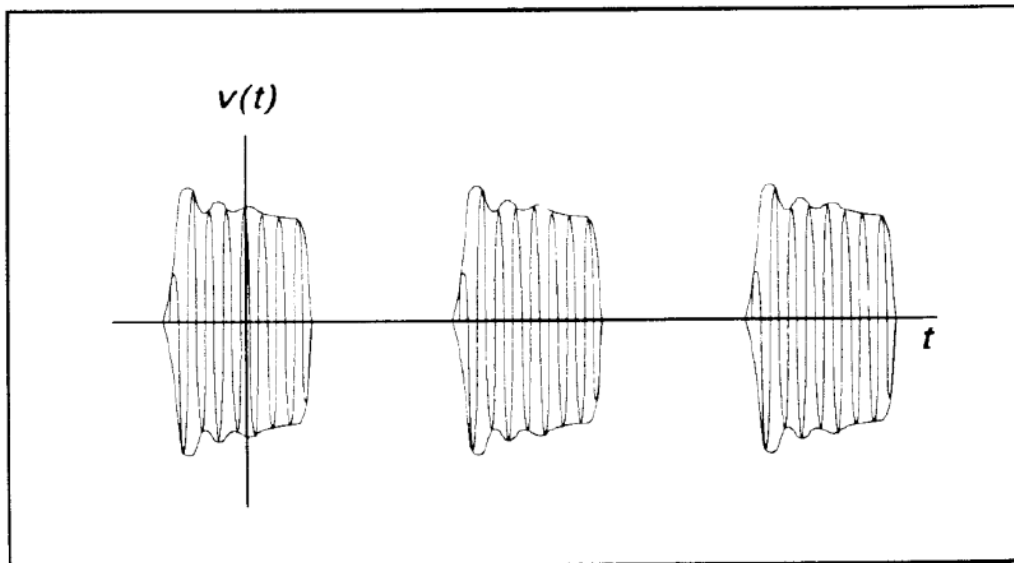

Figure 5-2. Distorted Pulsed Signal

Peak Power. The Model PMX40 makes power measurements in a manner that overcomes the limitations of the pulse power method and provides both peak power and average power readings for all types of modulated carriers. The fast-responding diode sensors detect the RF signal to produce a wideband video signal, which is sampled with a narrow sampling gate. The video sample levels are accurately converted to power on an individual basis at up to a 100 MSa/sec rate. Since this power conversion is corrected based upon the sensor's linearity correction table, these samples can be averaged to yield average power without restriction to the diode square-law region. In addition, if the signal is repetitive, the signal envelope can be reconstructed using an internal or external trigger. The envelope can be analyzed to obtain waveshape parameters including, pulse width, duty cycle, overshoot, rise time, fall time, and droop. In addition to time domain measurements and simple

averaging, the Model PMX40 has additional capabilities that allow it to perform statistical analysis on a complete set of continuously sampled data points. Data can be viewed and characterized using a CCDF presentation format. These analysis tools provide invaluable information about peak power levels and their frequency of occurrence, and are especially useful for non-repetitive signals, such as those used in 5G and Wi-Fi applications.

5.1.2 Diode Detection

Wideband diode detectors are the dominant power sensing device used to measure pulsed RF signals. However, several diode characteristics must be compensated to make meaningful measurements. These include the detector's nonlinear amplitude response, temperature sensitivity, and frequency response characteristic. Additional potential error sources include detector mismatch, signal harmonics, and noise.

Detector Response. The response of a single-diode detector to a sinusoidal input is given by the diode equation:

$$i = I_s(e^{\alpha v} - 1)$$

where:

i = diode current

v = net voltage across the diode

I_s = saturation current

α = constant

An ideal diode response curve is plotted in Figure 5-3.

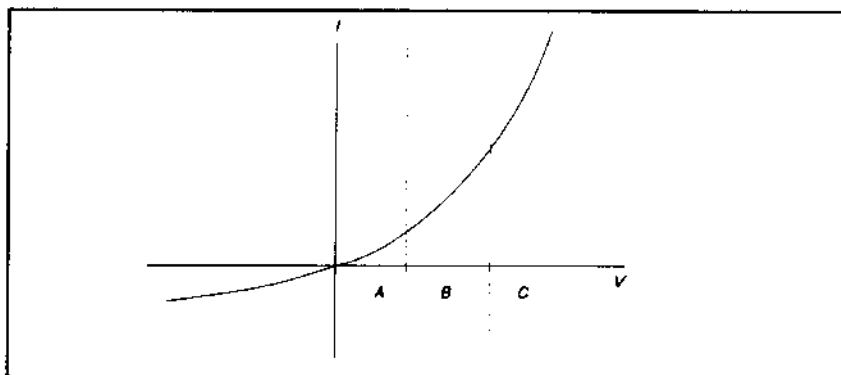

Figure 5-3.
Ideal Diode Response

The curve indicates that for low microwave input levels (Region A), the single-diode detector output is proportional to the square of the input power. For high input signal levels (Region C), the output is linearly proportional to the input. In between these ranges (Region B), the detector response lies between square-law and linear.

For accurate power measurements over all three regions illustrated in Figure 5-3, the detector response is pre-calibrated over the entire range. The calibration data is stored in the instrument and recalled to adjust each sample of the pulse power measurement.

Temperature Effects. The sensitivity of microwave diode detectors (normally Low Barrier Schottky diodes) varies with temperature. However, ordinary circuit design procedures that compensate for temperature-induced errors adversely affect detector bandwidth. A more effective approach involves sensing the ambient temperature during calibration and recalibrating the sensor when the temperature drifts outside the calibrated range.

This process can be made automatic by collecting calibration data over a wide temperature range and saving the data in a form that can be used by the power meter to correct readings for ambient temperature changes.

Frequency Response. The carrier frequency response of a diode detector is determined mostly by the diode junction capacitance and the device lead inductances. Accordingly, the frequency response will vary from detector to detector and cannot be compensated readily. Power measurements must be corrected by constructing a frequency response calibration table for each detector.

Mismatch. Sensor impedance matching errors can contribute significantly to measurement uncertainty, depending on the mismatch between the device under test (DUT) and the sensor input. This error cannot be easily calibrated out, but can be minimized by employing an optimum matching circuit at the sensor input.

Signal Harmonics. Measurement errors resulting from harmonics of the carrier frequency are level-dependent and cannot be calibrated out. In the square-law region of the detector response (Region A, Figure 5-3), the signal and second harmonic combine on a root mean square basis. The effects of harmonics on measurement accuracy in this region are relatively insignificant. However, in the linear region (Region C, Figure 5-3), the detector responds to the vector sum of the signal and harmonics. Depending on the relative amplitude and phase relationships between the harmonics and the fundamental, measurement accuracy may be significantly degraded. Errors caused by even-order harmonics can be reduced by using balanced diode detectors for the power sensor. This design responds to the peak-to-peak amplitude of the signal, which remains constant for any phase relationship between fundamental and even-order harmonics. Unfortunately, for odd-order harmonics, the peak-to-peak signal amplitude is sensitive to phasing, and balanced detectors provide no harmonic error improvement.

Noise. For low-level signals, detector noise contributes to measurement uncertainty and cannot be calibrated out. Balanced detector sensors improve the signal-to-noise ratio by 3 dB, because the signal is twice as large.

5.2 Pulse Definitions

IEEE Std 194™-1977 Standard Pulse Terms and Definitions “provides fundamental definitions for general use in time domain pulse technology.” Several key terms defined in the standard are reproduced in this subsection, which also defines the terms appearing in the PMX40 text mode display of automatic measurement results.

5.2.1 Standard IEEE Pulse

The key terms defined by the IEEE standard are abstracted and summarized below. These terms are referenced to the standard pulse illustrated in Figure 5-4.

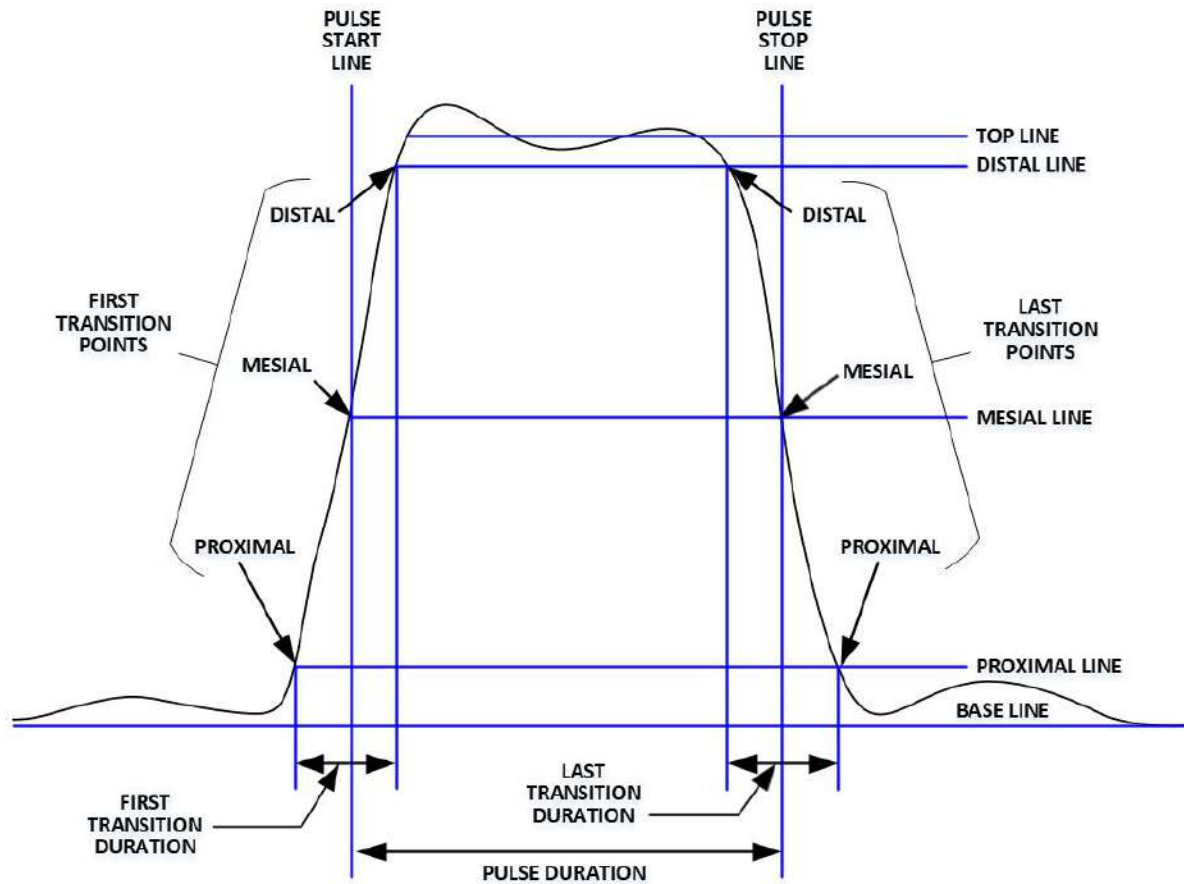

Figure 5-4. IEEE Standard Pulse (IEEE Std 194™-1977)

Note



IEEE Std 194™-1977 Standard Pulse Terms and Definitions has been superseded by IEEE Std 181™-2003. Many of the terms used below have been deprecated by the IEEE. However, these terms are widely used in the industry and familiar many. For this reason, they are retained.

Table 5-1. Pulse Terms

TERM	DEFINITION
Base Line	The two portions of a pulse waveform which represent the first nominal state from which a pulse departs and to which it ultimately returns.
Top Line	The portion of a pulse waveform which represents the second nominal state of a pulse.

PMX40 RF Power Meter – INSTRUCTION MANUAL

First Transition	The major transition of a pulse waveform between the base line and the top line (commonly called the rising edge).
Last Transition	The major transition of a pulse waveform between the top of the pulse and the base line (commonly called the falling edge).
Proximal Line	A magnitude reference line located near the base of a pulse at a specified percentage (normally 10%) of pulse magnitude.
Distal Line	A magnitude reference line located near the top of a pulse at a specified percentage (normally 90%) of pulse magnitude.
Mesial Line	A magnitude reference line located in the middle of a pulse at a specified percentage (normally 50%) of pulse magnitude.

5.3 Automatic Measurements

The PMX40 automatically analyzes the waveform data in the buffers and calculates key waveform parameters. The calculated values are displayed in text mode when you press the TEXT/GRAPH system key.

5.3.1 Automatic Measurement Criteria

Automatic measurements are made on repetitive signals that meet the following conditions:

- *Amplitude.* The difference between the top and bottom signal amplitudes must exceed 6 dB to calculate waveform timing parameters (pulse width, period, duty cycle). The top-to-bottom amplitude difference must exceed 13 dB to measure rise and fall time.
- *Timing.* In order to measure pulse repetition frequency and duty cycle, there must be at least three signal transitions. The interval between the first and third transition must be at least 1/5 of a division (1/50 of the screen width). For best accuracy on rise and fall time measurements, the timebase should be set so the transition interval is at least one-half division on the display.

5.3.2 Automatic Measurement Terms

The following terms appear in the PMX40 Text display in the Pulse mode. The Text column lists the abbreviated forms that appear on the display screen.

Table 5-2. Automatic Measurement Terms

Text	TERM	DEFINITION
Width	Pulse Width	The interval between the first and second signal crossings of the mesial line.
Rise	Risetime	The interval between the first signal crossing of the proximal line to the first signal crossing of the distal line.

PMX40 RF Power Meter – INSTRUCTION MANUAL

Fall	Falltime	The interval between the last signal crossing of the distal line to the last signal crossing of the proximal line.
Period	Pulse Period	The interval between two successive pulses (reciprocal of the Pulse Repetition Frequency).
PRFreq	Pulse Repetition Frequency	The number of cycles of a repetitive signal that take place in one second.
Duty C	Duty Cycle	The ratio of the pulse on-time to off-time.
Offtime	Off-time	The time a repetitive pulse is off (equal to the pulse period minus the pulse width).
Peak	Peak Power	The maximum power level of the captured waveform.
Pulse	Pulse Power	The average power level across the pulse width, defined by the intersection of the pulse rising and falling edges with the mesial line.
Oversh	Overshoot	A distortion following a major transition (the difference between the maximum amplitude of the overshoot and the top line).
Avg	Average Power	The equivalent heating effect of a signal.
IEEETop	Top Amplitude	The amplitude of the top line (see IEEE definitions).
IEEEBot	Bottom Amplitude	The amplitude of the base line (see IEEE definitions).
Skew	Skew	The time between the mesial level of a pulse on one channel and a pulse on a second channel.
EdgeDly	Edge Delay	The time between the left edge of the display and the first mesial transition level of either slope on the waveform.

5.3.3 Automatic Measurement Sequence

The automatic measurement process analyzes the captured signal data in the following sequence:

1. Approximately 500 samples of the waveform (equivalent to one screen width) are scanned to determine the maximum and minimum sample amplitudes.
2. The difference between the maximum and minimum sample values is calculated and stored as the Signal Amplitude.
3. The Transition Threshold is computed as one-half the sum of the maximum and minimum sample amplitudes.
4. The processor locates each crossing of the Transition Threshold.

PMX40 RF Power Meter – INSTRUCTION MANUAL

5. Starting at the left edge of the screen, the processor classifies each Transition threshold crossing according to whether it is positive-going (– +) or negative-going (+ –). Because the signal is repetitive, only three transitions are needed to classify the waveform, as follows:

Type	Sequence	Description
0	none	No crossings detected
1		Not used
2	+ –	One falling edge
3	– +	One rising edge
4	+ – +	One falling, followed by one rising edge
5	– + –	One rising, followed by one falling edge
6	+ – + –	Two falling edges
7	– + – +	Two rising edges

**Figure 5-5.
Step Waveforms**

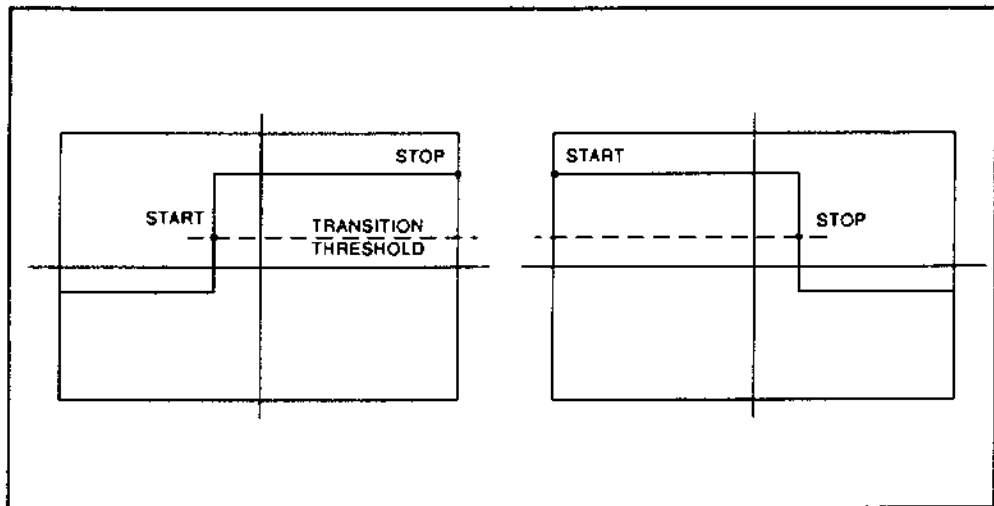

6. If the signal is Type 0, (No crossings detected) no measurements can be performed and the routine is terminated, pending the next reload of the data buffers.

7. The process locates the bottom amplitude (baseline) using the IEEE histogram method. A histogram is generated for all samples in the lowest 12.8 dB range of sample values. The range is subdivided into 64 power levels of 0.2 dB each. The histogram is scanned to locate the power level with the maximum number of crossings. This level is designated the baseline amplitude. If two or more power value have equal counts, the lowest is selected.

8. The process follows a similar procedure to locate the top amplitude (top line). The power range for the top histogram is 5 dB and the resolution is 0.02 dB, resulting in 250 levels. The level-crossing histogram is computed for a single pulse, using the samples which exceed the transition threshold. If only one transition exists in the buffer (Types 2 and 3), the process uses the samples that lie between the edge of the screen and the transition threshold (see Figure 5-6). For a level to be designated the top amplitude, the number of crossings of that level must be at least 1/16 the number of pixels in the pulse width; otherwise, the peak value is designated the top amplitude.

PMX40 RF Power Meter – INSTRUCTION MANUAL

9. The process establishes the proximal, mesial, and distal levels as a percentage of the difference between top amplitude and bottom amplitude power. The percentage can be calculated on a power or voltage basis. The proximal, mesial, and distal threshold values are user settable from 1% to 99%, with the restriction that the proximal < mesial < distal. Normally, these values will be set to 10%, 50%, and 90%, respectively.

Figure 5-6.
Time Interpolation

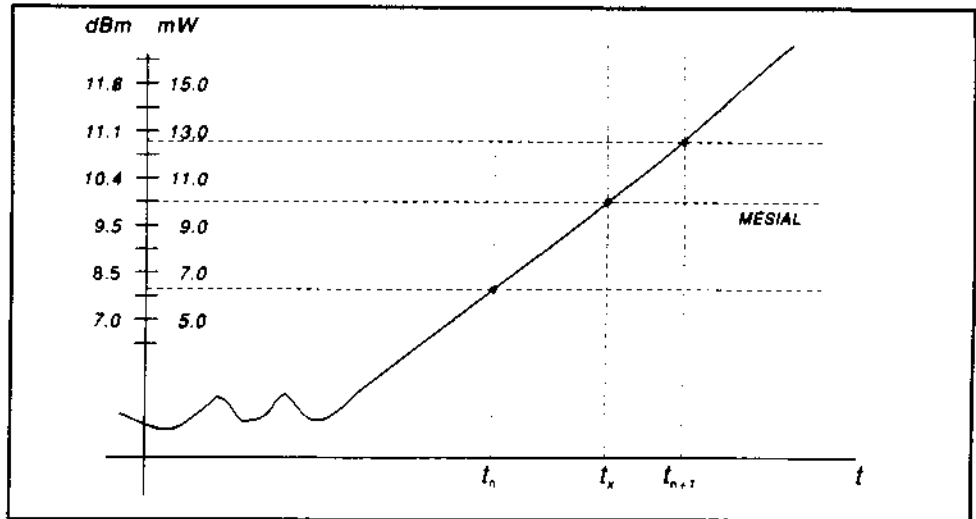

10. The process determines horizontal position, in pixels, at which the signal crosses the mesial value. This is done to a resolution of 0.1 pixel, or 1/5000 of the screen width. Ordinarily, the sample values do not fall precisely on the mesial line, and it is necessary to interpolate between the two nearest samples to determine where the mesial crossing occurred. This process is demonstrated in the example above (Figure 5-6):

Item	dBm	mW
Mesial value	10.0	10.0
Sample n	8.0	6.3
Sample n+1	11.0	12.6

The interpolated crossing time, t_x , is calculated from:

$$t_x = t_n + \frac{P_{mes} - P_n}{P_{n+1} - P_n}$$

where P is in watts and n is the number of the sampling interval, referenced to the trigger event. For this example

$$t_x = t_n + \frac{10.0 - 6.3}{12.6 - 6.3}$$

$$t_x = t_n + 0.6$$

PMX40 RF Power Meter – INSTRUCTION MANUAL

11. The processor computes the rise and/or fall times of waveforms that meet the following conditions:
- a) The waveform must have at least one usable edge (Types 2 through 7).
 - b) The signal peak must be at least 13 dB greater than the minimum sample value.
- The rise time is defined as the time between the proximal and distal crossings (– +).
The fall time is defined as the time between the distal and proximal crossings (+ –).
If no samples lie between the proximal and distal values for either edge (rise or fall), the risetime for that edge is set to 0 seconds.
12. The processor calculates the output values according to the following definitions:
- a) Pulse Width Interval between mesial points
 - b) Rise time See Step 11
 - c) Fall time See Step 11
 - d) Period Cycle time between mesial points
 - e) Pulse Repetition Reciprocal of Period Frequency
 - f) Duty Cycle Pulse Width/Period
 - g) Off-time (Period) - (Pulse Width)
 - h) Peak Power Maximum sample value (See Step 1)
 - i) Pulse Power Average power in the pulse (between the mesial points)
 - j) Overshoot (Peak Power) - (Top Amplitude)
 - k) Average Power See Step 13
 - l) Top Amplitude See Step 8
 - m) Bottom Amplitude See Step 7
 - n) Skew See Step 14

5.3.4 Average Power Over an Interval

13. The average power of the signal over a time interval is computed by:
- a) summing the sample powers in the interval
 - b) dividing the sum by the number of samples

This process calculates Pulse Power, Average Power, and the average power between markers.

Since each sample represents the power in a finite time interval, the endpoints are handled separately to avoid spreading the interval by one-half pixel at each end of the interval (see Figure 5-7). For the interval in Figure 5-7, the average power is given by:

$$P_{avg} = \frac{1}{2}(P_0 + P_n) + \frac{1}{(n-1)} \sum_{n=1}^{n-1} P_n$$

Figure 5-7.
Sampling Intervals

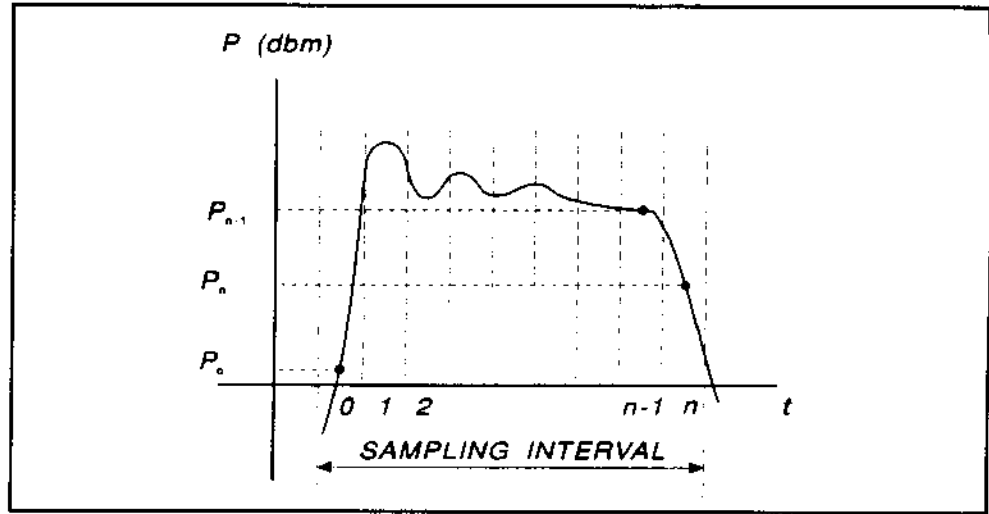

14. The processor calculates the delay between the two measurement channels. The time reference for each channel is established by the first signal crossing (starting from the left edge of the screen) which passes through the mesial level. The signal excursion must be at least 6 dB.

5.4 Statistical Mode Automatic Measurements

When operating in Statistical mode, the PMX40 has a unique text format display that is available when the TEXT/GRAPH system key is pressed. A sample of the text display is shown in Figure 5-8.

Param	CH1	CH2
Avg	-2.239 dBm	7.624 dBm
Min	-Low- dBm	-36.736 dBm
Max	7.069 dBm	12.029 dBm
Pk2Avg	9.308 dB	4.406 dB
Cursor Pwr	8.274 dB	4.038 dB
Cursor Pct	0.0100%	0.0100%
Points	1.186 GSa	1.186 GSa
Total Time	0:00:36	0:00:36
10%	3.648 dB	2.750 dB
1%	6.315 dB	3.564 dB
0.1%	7.500 dB	6.870 dB

Pulse Mode
Cont. Mode
Stat. Mode

Figure 5-8. Statistical Mode Text Display

PMX40 RF Power Meter – INSTRUCTION MANUAL

Table 5-3. Statistical Automatic Measurements

In the Statistical mode the following five automatic measurements are displayed in the PMX40 Text display for both input channels and both trigger channels. The Text column lists the abbreviated forms that appear on the display screen.

Text	TERM	DEFINITION
Avg	Average Power	The unweighted average of all linear power samples occurring since acquisition started.
Peak	Peak Power	The highest power sample occurring since acquisition was started.
Min	Minimum Power	The lowest power sample occurring since acquisition was started. In logarithmic units a reading below the clip level will display as down arrows.
Pk2Avg	Pk/Avg Ratio	The ratio (in dB) of the Peak Power to the Average Power.

The following six cursor measurements display the set position (independent variable) and measured value (dependent variables) where the movable cursor intersects the measurement trace. The position or value measurement text for each dependent variable is displayed in the color of its channel. The independent variable is white. Note that the intersection of the movable cursors and the CCDF traces can be moved outside the visible display area. This does not affect the measurements in any way.

Text	TERM	DEFINITION
Cursor Pwr	Cursor Power Reference	<p>Cursor Mode - Power Ref The reference power level in dBr set by the user to define the measurement point on the normalized CCDF for probability in percent.</p> <p>Cursor Mode - Percent The measured power level in dBr of the normalized CCDF at the Probability in percent specified by the user.</p>
Cursor Pct	Cursor Percentage	<p>Cursor Mode - Power Ref The measured probability in percent of the normalized CCDF at the reference power level specified by the user.</p> <p>Cursor Mode - Percent The probability in percent set by the user to define the measurement point on the normalized CCDF for power level in dBr.</p>

PMX40 RF Power Meter – INSTRUCTION MANUAL

The following two global status values are displayed:

Text	TERM	DEFINITION
Total	Time	The total time in Hours:Minutes:Seconds that the data acquisition has been running.
	Points	The total number of data samples in MSa that has been acquired for each channel in the current run.

Note



The total number of data samples is affected by the terminal settings. If Terminal Action is set to decimate, then the sample count will be halved each time the Terminal Count or Time is reached. This should have very little visible effect on the CCDF values, since the entire population is decimated uniformly. If Terminal Action is set to restart, then the sample count will be cleared to zero each time the Terminal Count or Time is reached.

5.5 Measurement Accuracy

The measurement accuracy of the PMX40 is completely contingent upon the USB sensor with which it is being used. Please reference the sensor datasheet and/or associated uncertainty calculator for measurement uncertainties associated with a specific sensor.

6 Maintenance

This section presents procedures for maintaining the PMX40.

6.1 Safety

Although the PMX40 has been designed in accordance with international safety standards, general safety precautions must be observed during all phases of operation and maintenance. Failure to comply with the precautions listed in the Safety Summary located in the front of this manual could result in serious injury or death. Service and adjustments should be performed only by qualified service personnel.

6.2 Cleaning

Painted surfaces can be cleaned with a commercial spray-type window cleaner or a mild detergent and water solution.

Caution



When cleaning the instrument, do not allow cleaning fluid to enter the fan intake and exhaust vents. Avoid using chemical cleaning agents that can damage painted or plastic surfaces.

6.3 Inspection

If the PMX40 malfunctions, perform a visual inspection of the instrument. Inspect for signs of damage caused by excessive shock, vibration, or overheating. Inspect for broken wires, loose electrical connections, or accumulations of dust or other foreign matter.

Correct any problems you discover, reboot the instrument, and observe the self-test results (see Figure 6-1). If the malfunction persists or the instrument fails the performance verification, contact Boonton Electronics for service.

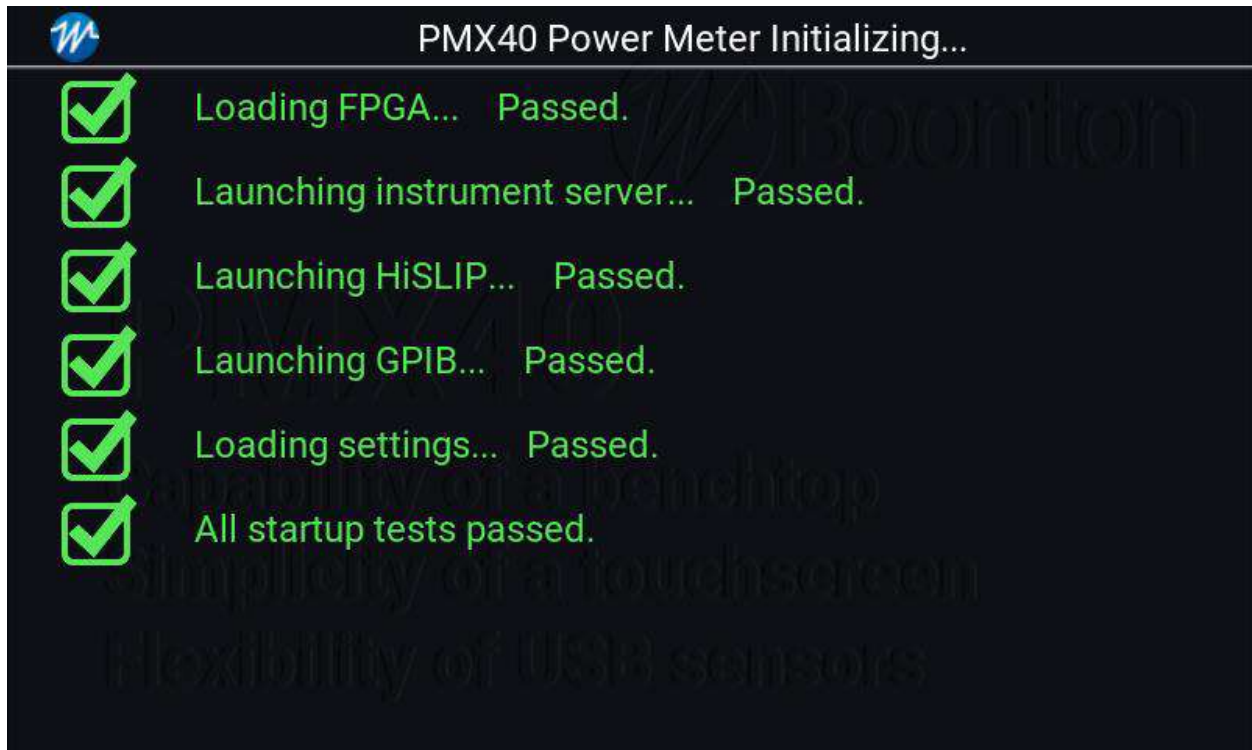

Figure 6-1. Self-Test Results

6.4 Lithium Battery

The PMX40 contains one Lithium “coin cell” battery to provide for non-volatile storage of the instrument state. This is located on the Main Printed Circuit assembly. It should have a life of 5-10 years. When replacement is necessary, the battery must be disposed of in strict compliance with local environmental regulations.

6.5 Software Upgrade

Instrument operating software has been loaded into the Model PMX40 at the factory, including the Boonton Electronics Model PMX40 Application Software. The Application Software will be updated from time to time to correct errors and add new features. Users can upgrade their software by downloading it from the Boonton Electronics webpage, www.boonton.com. Copy the upgrade file(s) into the root directory on a USB drive, and plug the drive into one of the instrument’s USB ports (front or rear). From the PMX40 application, select the System menu, and select Go under Update Software.

Caution



When loading new software into the Model PMX40, some or all stored instrument configurations and preset operating selections may be lost. Contact Boonton Electronics for information on which files may be affected.

Appendix A - Warranty and Repair Policy

Model PMX40 Instrument

If the Boonton Model PMX40 RF Power Meter is not operating correctly and requires service, contact the Boonton Electronics Service Department for return authorization. You will be provided with an RMA number and shipping instructions. Customers outside the USA should contact the authorized Boonton distributor for your area. The entire instrument must be returned in its original packing container. If the original container is not available, Boonton Electronics will ship a replacement container and you will be billed for the container cost and shipping charges.

Boonton USB RF Power Sensors

Damaged or defective peak power sensors are repaired as separate instruments. Note that sensors which have failed due to overloading, improper mating, or connecting to an out-of-tolerance connector are not considered defective and will not be covered by the Boonton Warranty. If repair is needed, contact the Boonton Electronics Service Department for return authorization. You will be provided with an RMA number and shipping instructions. Customers outside the USA should contact the authorized Boonton distributor for your area. Only the defective sensor should be returned to Boonton, not the entire instrument. The sensor must be returned in its original packing container. If the original container is not available, Boonton Electronics will ship a replacement container and you will be billed for the container cost and shipping charges. If a new sensor is ordered, note that it does not include a sensor cable - this item must be ordered separately.

Contacting Boonton

Customers in the United States having questions or equipment problems may contact Boonton Electronics directly during business hours (8 AM to 5 PM Eastern) by phoning (973) 386-9696. FAX messages may be sent at any time to (973) 386-9191. E-mail inquiries should be sent to service@boonton.com. International customers should contact their authorized Boonton Electronics representative for assistance. A current list of authorized US and international representatives is available on the Boonton website at www.boonton.com.

Appendix B - End User License Agreement

Available upon written request.

-- END --

PMX40 RF POWER METER
INSTRUCTION MANUAL